



GM10 / 150 / 190 / 250 / 350 / 450 / 550 / 327 / 431 / 532  
WS 10-14 P / WS 10-14 SP / WS 15-27 P / WS 18-35 D / WS 18-35 DT  
WS 10 PTO / WS 15 PTO / WS 18 PTO / WS 20 PTO / WS 23 PTO

## OPERATING MANUAL

saelen.fr ts-industrie.eu

**SAELEN<sup>®</sup> TS** INDUSTRIE<sup>®</sup>

# EC Declaration of Conformity

Corresponding with the EC Directive 2006/42/EC

We, TS Industrie GmbH \_\_\_\_\_

Weserstr. 2, 47506 Neukirchen-Vluyn \_\_\_\_\_

declare on our own responsibility that the product

TS wood shredder type GM10, 150, 170, 190, 250, 327, 350, 431, 450, 532, 550, (including M and Z variations)  
WS 15-27 P, WS 18-35 D, WS 18-35 DT, WS 10 PTO, WS 15 PTO, WS 18PTO, WS 20 PTO/ZS/ZSA, WS 23 PTO/ZS/ZSA

\_\_\_\_\_

which this declaration relates to, corresponds with the relevant basic health and safety requirements of  
EC directive 2006/42/EC  
and the requirements of the other relevant

2014/30/EU

2014/35/EU

\_\_\_\_\_

The technical documents are kept in the main factory.  
For correct implementation of the health and safety requirements specified in the EC directive, the following norm  
(s) and/or technical specification(s) are applied:

EN ISO 12100:2010  
EN ISO 13857, EN 349+A1, EN ISO 4413, EN ISO 4254-1, RL 2000/14/EG, EN 60529/A2, EN 60204-1/A1

Neukirchen-Vluyn, 28.05.15  
(Place and date of issue )

Joosten  
Technical Manager

# CAUTION!

Before delivery of our machines, they go through a strict quality control in the factory.

Because the machine is no longer under our influence when it has left the factory, another check by the retailer must be made before delivery to the end customer.

The following is to be checked:

- External damages due to transport etc.
- All screws and hose connections for tightness
- Oil, water and fuel filling level
- Complete functional control of all parts

This inspection is recorded with a stamp and signature on the machine delivery note. There is no claim to warranty without returning the fully completed and signed delivery note!

**Furthermore, all screw connections must be checked for a tight fit before initial use and the hose lines checked for areas of abrasion!**

**Please directly arrange an appointment with your customer for this.**

Regular inspections according to the operating manual are to be met!

Controlled quality - an important step towards customer satisfaction!

Please cooperate!

# Warranties

## Processing warranty claims

Warranty claims according to the manufacturer's general terms of business are valid for 1 year from the date of delivery.

The handover date stated on the machine delivery note is decisive for the time of transfer of risk.

Warranty claims are generally to be reported to the contract retailer making the delivery.

The recorded parts of the delivered machine must generally be kept without any changes due to the proof reasons until final processing of the enforced warranty claim. In the event of a warranty claim, the claimed part of the machine (or old part) is to be provided free domicile to the manufacturer or the sales retailer.

A technical change to the machine and/or parts thereof leads to the loss of all warranty claims.

The same applies in the case of incorrect handling or use of lubricants or spare parts and accessories not approved or specified by the manufacturer. Transport damages and damages that are caused by normal wear and tear after initialisation of the machine are not usually valid for warranty claims.

The delivered machine is to be subjected to the specified obligatory visual checks or inspections according to the specified intervals in the maintenance plan provided. In the event of non-compliance with the obligatory visual checks and inspection plan, all warranty claims are void.

A further prerequisite for a warranty claim is the submission of full proof of the obligatory visual checks and inspections performed.

Any warranty and maintenance work may only be performed by a specialist retailer authorised by TS.

It is pointed out that the warranty work exceeding a value of 150.00€ must generally be coordinated with TS and approved by TS. The manufacturer reserves the right to perform the repair himself in this case.



A prerequisite for enforcement of a warranty claim is the return of the fully completed and signed machine delivery note.

# Contents

<b>1</b>	<b>FOREWORD</b> .....	<b>8</b>
<b>2</b>	<b>INTRODUCTION</b> .....	<b>9</b>
<b>3</b>	<b>SAFETY REGULATIONS</b> .....	<b>10</b>
<b>3.1</b>	<b>Joint Shafts</b> .....	<b>14</b>
<b>4</b>	<b>PICTOGRAMS</b> .....	<b>15</b>
<b>5</b>	<b>TECHNICAL DESCRIPTIONS</b> .....	<b>16</b>
<b>5.1</b>	<b>Retraction</b> .....	<b>16</b>
<b>5.2</b>	<b>Ejection chimney</b> .....	<b>20</b>
<b>5.3</b>	<b>Transport position</b> .....	<b>20</b>
<b>5.4</b>	<b>Ejection flap</b> .....	<b>20</b>
<b>5.5</b>	<b>Ejection cover</b> .....	<b>21</b>
<b>5.6</b>	<b>Clamping device</b> .....	<b>21</b>
<b>5.7</b>	<b>Motor rocker</b> .....	<b>22</b>
<b>5.8</b>	<b>Support</b> .....	<b>22</b>
<b>5.9</b>	<b>Rotating ring lock</b> .....	<b>22</b>
<b>5.10</b>	<b>Attachment to a vehicle</b> .....	<b>23</b>
<b>5.11</b>	<b>GM10M Pull&amp;Push (switching the second wheel)</b> .....	<b>23</b>
<b>5.12</b>	<b>Attachment to a tractor</b> .....	<b>24</b>
<b>5.13</b>	<b>Drive on Z-machines</b> .....	<b>25</b>
<b>5.14</b>	<b>Pivoting Z-machines (special equipment)</b> .....	<b>25</b>
<b>5.15</b>	<b>Testing the blade and counter blade</b> .....	<b>26</b>
<b>5.16</b>	<b>Testing the safety equipment</b> .....	<b>26</b>
<b>6</b>	<b>OPERATION AND IMPLEMENTATION</b> .....	<b>27</b>
<b>6.1</b>	<b>Funnel flap with manual switching</b> .....	<b>27</b>
<b>6.2</b>	<b>Funnel flap with electric switching</b> .....	<b>28</b>

<b>6.3</b>	<b>Switch bracket setting</b> .....	<b>29</b>
<b>6.4</b>	<b>Bracket force setting</b> .....	<b>29</b>
<b>6.5</b>	<b>Funnel flap locking</b> .....	<b>29</b>
<b>6.6</b>	<b>Material entry and operation</b> .....	<b>30</b>
<b>6.7</b>	<b>Operation</b> .....	<b>31</b>
<b>6.8</b>	<b>Noise emissions</b> .....	<b>31</b>
<b>6.9</b>	<b>Blockages</b> .....	<b>32</b>
<b>6.10</b>	<b>Transport position</b> .....	<b>32</b>
<b>6.11</b>	<b>Cleaning the machine</b> .....	<b>32</b>
<b>6.12</b>	<b>ABS-System</b> .....	<b>33</b>
<b>7</b>	<b>MAINTENANCE AND REPAIR</b> .....	<b>34</b>
<b>7.1</b>	<b>Maintenance for wood shredders</b> .....	<b>35</b>
<b>7.2</b>	<b>Checking the screws</b> .....	<b>37</b>
<b>7.3</b>	<b>Ball bearings</b> .....	<b>37</b>
<b>7.4</b>	<b>V-belts</b> .....	<b>37</b>
<b>7.5</b>	<b>Hacking blades and counterblades</b> .....	<b>38</b>
<b>7.6</b>	<b>Grinding instructions</b> .....	<b>41</b>
<b>8</b>	<b>LUBRICATION PLAN</b> .....	<b>42</b>
<b>8.1</b>	<b>GM 10 M Pull &amp; Push or WS 10-14 SP</b> .....	<b>42</b>
<b>8.2</b>	<b>GM 10 M 80km/h or WS 10-14 P</b> .....	<b>43</b>
<b>8.3</b>	<b>150 M or WS 15-27 P</b> .....	<b>44</b>
<b>8.4</b>	<b>170/190 M or WS 18-35 D</b> .....	<b>45</b>
<b>8.5</b>	<b>250M or WS 18-35 DT</b> .....	<b>46</b>
<b>8.6</b>	<b>350/450 M</b> .....	<b>47</b>
<b>8.7</b>	<b>550 M</b> .....	<b>48</b>
<b>8.8</b>	<b>Z-machines</b> .....	<b>49</b>

<b>9</b>	<b>Control element of KUBOTA engine.....</b>	<b>50</b>
<b>9</b>	<b>HMC 542 .....</b>	<b>51</b>
<b>9.1</b>	<b>General .....</b>	<b>51</b>
<b>9.2</b>	<b>Programming the parameters .....</b>	<b>51</b>
<b>9.3</b>	<b>Normal operation .....</b>	<b>51</b>
<b>9.4</b>	<b>view.....</b>	<b>52</b>
<b>9.5</b>	<b>Key functions.....</b>	<b>53</b>
<b>10</b>	<b>HC 960.....</b>	<b>54</b>
<b>10.1</b>	<b>General .....</b>	<b>54</b>
<b>10.2</b>	<b>Technical data.....</b>	<b>54</b>
<b>10.3</b>	<b>AMP plug.....</b>	<b>55</b>
<b>10.4</b>	<b>Pilot System.....</b>	<b>56</b>
<b>11</b>	<b>BIO HYDRAULIC OIL .....</b>	<b>66</b>
<b>12</b>	<b>PREFERRED HVI HYDRAULIC OIL</b>	
<b>13</b>	<b>HYDRAULIC PLANS.....</b>	<b>67</b>
<b>13.1</b>	<b>WOOD SHREDDER WITH ABS.....</b>	<b>67</b>
<b>13.2</b>	<b>WOOD SHREDDER WITH ABS + EPS.....</b>	<b>68</b>
<b>13.3</b>	<b>GM10 Pull&amp;Push.....</b>	<b>69</b>
<b>14</b>	<b>ELECTRICAL DIAGRAMS.....</b>	<b>70</b>
<b>14.1</b>	<b>170M / 190M / 250M.....</b>	<b>70</b>
<b>14.2</b>	<b>350M / 450M / 550M.....</b>	<b>73</b>
<b>14.3</b>	<b>General EPS (electric switching).....</b>	<b>76</b>
<b>14.4</b>	<b>GM10M .....</b>	<b>78</b>
<b>15</b>	<b>INSPECTIONS .....</b>	<b>80</b>

## Foreword

We thank you for your decision to purchase a TS Industrie wood shredder. Your TS Industrie wood shredder has been produced with great care to high quality requirements. In order to satisfy these requirements, including professional requirements, we ask you to read this operating manual conscientiously and comply with the warning and maintenance instructions.

We can only provide the full manufacturer's guarantee for the TS Industrie wood shredder with compliance of all maintenance work at the specified intervals.

This operating manual covers several models so the introduction explains how you can find your way around with the help of little pictograms.





# Introduction

This operating manual covers several types of wood shredders. Some information only relates to certain models which are clearly marked with the help of little pictograms.

Please compare the relevant type description on your type label with the types listed below.

Please always state the type and comm. no. when making enquiries.



## Motor machine

GM10M or WS 10-14 SP  
150M or WS 15-27 P  
190M or WS 18-35 D  
250M or WS 18-35 DT  
350ME/MT  
450M  
550M

## PTO shaft machines

GM10Z or WS 10 PTO  
170Z or WS 15 PTO  
190Z or WS 18PTO  
327Z or WS 20 PTO/ZS/ZSA  
431Z or WS 23 PTO/ZS/ZSA  
532Z



Warning information is always shown like this and must be taken into account!

---

## Safety Regulations

1. The machine may only be used according to the operating manual.
2. The operating manual for the drive motor must also be taken into account for motor machines.
3. Folding up the extraction extension may only be performed with the hacking disc at a standstill.
4. Maintenance, cleaning and setting work, as well as removing protective devices, may only be performed with the motor switched off, ignition switched, uncoupled drive and tools standing still. Remove the ignition key so that unintentional start-up is not possible.
5. Foreign matter, e.g. iron parts and stones etc, must be removed before operation.
6. After maintenance or repair, check whether all protective devices have been attached.
7. The wood shredder may not be taken into operation in rooms due to the associated risk of poisoning.
8. The hacking disc may only be removed once it has come to a standstill. This means that the drive motor is switched off and the ignition is in the 0-position.
9. The machine operator is responsible for making sure that third parties are not in the work and danger zone.
10. In the event of repairs, make sure that only original tested spare parts are used.
11. Only trained persons from 18 years may operate the wood shredder (from 16 years for the purpose of training, under supervision).

12. Safety footwear and closely fitting clothes as well as work gloves with close fitting cuffs, ear protectors and goggles must be used.

13. For transport, the wood shredders must be brought into the transport position:

A) Lift up the funnel flap and check whether the lock has clicked in.

B) Take the wood shredder into the transport position and check whether the security bolts are clicked in.

C) Turn the ejection channel so that it does not protrude beyond the side of the machine.

D) Push all parking locks up if necessary

14. When driving on public roads, the lighting must correspond with the German Traffic Road Regulations.

15. When working, the wood shredder must be positioned steadily in a horizontal position and must be secured against rolling away.

16. Single axle motor devices are attached to traction vehicles and, if available, the park brake is applied. For operation without a traction vehicle, the parking locks (front and back) must be lowered.

17. Minimum clearance of 10 m from the machine to the ejection must be maintained due to safety reasons. **The objection must always be averted by operating personnel**

18. You may only reach into the retraction opening with your hands when the motor has been shut down and the hacking disc has come to a standstill.

19. The authorised hydraulic operating pressure set in the factory may not be changed

Type	Operating pressure
GM10M/Z or WS 10-14 SP/PTO	180 bar
150M or WS 15-27 P	190 bar
170M/Z	190 bar
190M/Z or WS 18-35 D / PTO	190 bar
250M or WS 18-35 DT	190 bar
327Z or WS 20 PTO	190 bar
350ME/MT	190 bar
431Z or WS 23 PTO/S/ZSA	190 bar
450M	190 bar
532Z/ZS/ZSA	190 bar
550M	190 bar

**20.** Only trunks up to a certain diameter may be processed in the wood shredder. The following values apply:

GM10M/Z or WS 10-14 SP/PTO	up to ø 10 cm
150M or WS 15-27 P	up to ø 15 cm
170M/Z	up to ø 16 cm
190M/Z or WS 18-35 D / PTO	up to ø 18 cm
250M or WS 18-35 DT	up to ø 18 cm
327Z or WS 20 PTO/	up to ø 20 cm
350ME/MT	up to ø 20 cm
431Z or WS 23 PTO/ZS/ZSA	up to ø 23 cm
450M	up to ø 23 cm
532Z/ZS/ZSA	up to ø 26 cm
550M	up to ø 26 cm

**21.** The hydraulic system must be subjected to an expert inspection every year. The hydraulic hoses are to be replaced after five years.

**22.** Do not reach into the supply funnel when filling the wood shredder. Blockages must be dealt with safely (stop motor, use aids). To push short pieces or branch-like hacking items through, only use sturdy wooden sticks or other aids made of wood. I will wood shredders are only suitable for manual loading. Do not move around the ejection area.

**23.** Perform a function test every day before initialisation, especially on the safety equipment (switch rods, switch locks and off switches on covers of M versions). Hacking blades and counter blades are also to be tested for function and a tight fit.

**24.** Operating personnel must be inducted thoroughly before initialisation.

**25.** The hacking disc may only be released once it has come to a full standstill and the motor has been switched off. For work on the hacking disc or on cutting tools, the hacking disc must always be locked with the supplied hacking disc claw.

**26.** Danger due to flying parts. Attention must be paid that parts such as wood chips can also fly out of the funnel in the operating area. Body protection must always be attached (see page 15). The machine should be operated to the side of the funnel.

**27. Information for all motor machines:**

The tilted position of the motor may be a maximum of 25° during operation (driving). With too little oil, lubrication of the motor is not even guaranteed at 25°!

**28. GM10M:** the motor machine may not be driven in the full power mode. The utmost care must be taken when driving in reverse. Do not drive backwards towards fences or walls as there is the risk of crushing.

**29. GM10M:** Always drive the motor with reduced speed. The vehicle driver is solely responsible for ensuring that no persons are in the proximity of the machine. A safety distance of at least 10 m should be maintained. When driving, always keep the ejection chimney at the back, turn it away from the vehicle driver and push the flap downwards. Otherwise there is a risk that any chippings stuck in the hacking housing are projected afterwards (risk of injury).

**30.** Take care on slopes. The machine driver must ensure that the machine is always safely driven and is kept steady and safe during work.

**31. GM10M:** when loading, always make sure that the machine is driven straight onto a trailer otherwise there is the risk of it tipping over. The same applies when taking it off the trailer. In this case, it should be guided down with a safety rope otherwise there is the risk of the machine tipping over backwards. Make sure that no persons are within the danger zone when loading the machine.

**32.** When loading onto and off trailers, please make sure that the trailer is always secured against rolling away.

**33.** When attaching the three-point machine, no persons may remain between the machine and the tractor. There is a risk of crushing.

**34.** The PTO shaft machine must be suspended on the tractor properly and secured with bolts and folding splints. The safety pin on the joint shaft must click into place when sliding onto the shaft stub!

**35. Z-devices:** attachment to the tractor takes place in the lowered status (three point) with ground contact.

**36. Z-devices on the axle** are suspended on the tractor in the trailer hook and must remain suspending during operation.

**37.** For PTO shaft drives, attention is to be paid to the maximum PTO shaft speed (type label, sticker).

**38.** The machine may only be loaded with wood. Make sure that no stones or metals enter the machine.

## Joint Shafts

The following sizes are built in the factory.  
Only with free wheel and slide coupling!

Type	Building size	Free wheel	Slide coupling	Free wheel with slide coupling	Torque [Nm]
GM10Z or WS 10 PTO	T40	0410			
170Z or WS 15 PTO	104	096			900
190Z or WS 18PTO	104			553	1000
327Z or WS 20 PTO/	104	096	255/2		1000
327ZS	104	096		553	1000
431Z or WS 23 PTO/	106	096	255/2		1100
431ZS	106			563	1450
532Z	106	096	255/2		1200



**Caution:**

Joint shafts may only be used up to max. 10° bending angle!

At a bending angle of 10° to 35°, wide angle joint shafts are necessary!

## Pictograms

Wear goggles!  
Wear ear protectors!



Wear protective gloves with special close fitting cuffs!



Wear safety footwear!



Only touch machine parts when they have come to a complete standstill!



Maintain a sufficient distance from rotating machine parts!



## Pictograms

Never open and remove protective devices with the drive running!



Read the operating manual before initialisation!



Do not remain in the ejection area when the machine is running! Danger zone!

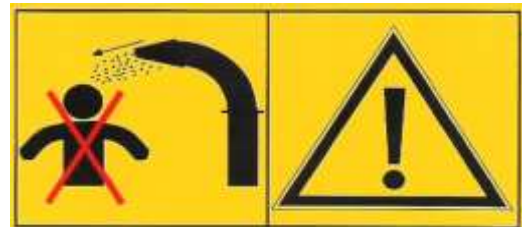

Switch the motor off and remove the key before maintenance and repair work!



Maintain a sufficient distance from hot surfaces (exhaust).



Secure the machine (transport trailer) before parking against unintentionally rolling away using wedges.

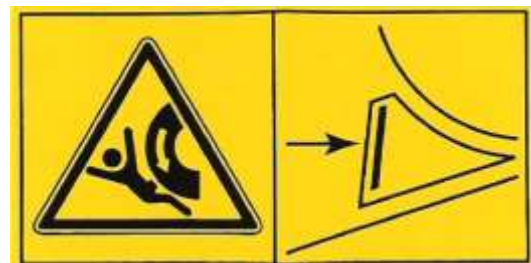



## Pictograms

Feed area of machine

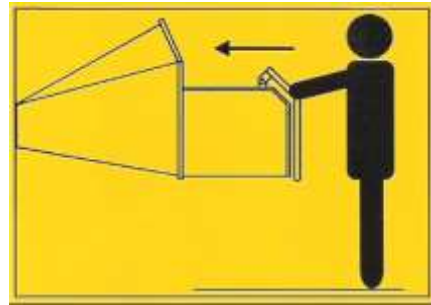

Hydraulic oil to be used

Hydrauliköl HLP46

Tyre air pressure

**2.5 bar**  
**3.5 bar**  
**4.5 bar**

Fill fuel tank with petrol

**Benzin**

Fill fuel tank with diesel

**Diesel**

## Technical Descriptions

### Retraction

The wood shredder exclusively serves the purpose of shredding wood (trunks and branches) and wood-like plants (hedges and bushes). They are exclusively designed for manual loading.

The items to be hacked or placed on the retraction table and drawn in by the retraction rollers, then guided against the rotating, closed hacking disc.

The cutting blades attached to the hacking disc now cut off the retracted material. The horizontally attached lower blade and the vertical upright side blade serve as an attachment (counter-cutter). The cut-off wood chips are transported through the ejection channel outside by the ejection wings attached to the hacking disc.



The retraction rollers are driven by hydraulic motors and can be controlled with the switch lever in the direction of rotation (forwards, stop, reverse and safety stop). Also refer to the sticker on the side of the funnel.



Depending on the type, the wood shredder is driven with a tractor and joint shaft or with an attached motor.

The funnel extension may only be folded up with the retraction rollers switched off - the switch bracket must be brought into the emergency stop position for this.

The ejection channel can be pivoted and locked at short distances. Please make sure that it is never pivoted into the operating area.



**Caution:**

Remaining chippings can be rejected when switching on the wood shredder.



## Ejection chimney

Before beginning work, it is compulsory to ensure that the ejection chimney is not pointing towards the operating area. The ejection must always take place away from the operating area. Impacts are attached to ensure this.

## Transport position

Transport position of the chimney. Before transport, the ejection chimney must be locked against the direction of travel. (To the back)

## Ejection flap

The ejection flap can be pivoted from the horizontal to the vertical position pointing downwards and progressively locked.

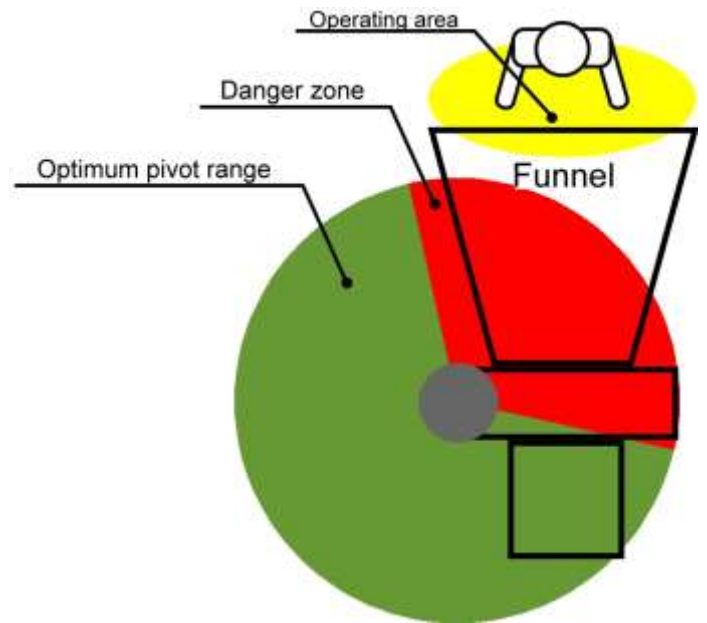

## Ejection cover

The ejection cover needs to be opened for any repair, assembly or setting work on the hacking machine. Before the cover can be opened, three or four nuts (depending on the model) need to be loosened.

The ejection cover can then be folded up. In order to reduce the necessary force when folding up, pivot the ejection channel to the opposite side beforehand (see photo) and lock it.



## Belt tensioning

Only start and stop the wood shredder with the clamping device in the uncoupled state with the engine idle! In order to increase the starter's service life, it is compulsory that the force transfer is uncoupled when starting other the starter has to pull the whole hacking disc along, transmitted by the belt. This should also have completed before shut-down because the hacking discs continue running here. This can produced cracks on the wood shredder and on the drive belt which can lead to consequential damages.

**150M:** the transfer of force takes place from the motor through a centrifugal coupling and from the V-belt to the hacking disc.



## Motor rocker

Only start and stop the wood shredder with the motor rocker in the uncoupled state with the engine idle! In order to increase the starter's service life, it is compulsory that the force transfer is uncoupled when starting other the starter has to pull the whole hacking disc along, transmitted by the belt. This should also have completed before shut-down because the hacking discs continue running here. This can produced cracks on the wood shredder and on the drive belt which can lead to consequential damages.



## Support

The support to the back must always be lowered when the wood shredder is uncoupled from the vehicle. This is how you can avoid the wood shredder tipping over.



## Rotating ring lock

When turning the hacker, attention must be paid that the locking lever is always clicked in.



## Attachment to a vehicle

When attaching the wood shredder to a vehicle, you must proceed as follows. Set the support wheel at the height of the drawbar so that the trailer tow bar is over the one on the vehicle. Now turn in the support wheel and the opened ball-head coupling must click into the ball on the tow bar.

Please check that it is clicked in!

Then connect the catch line to the vehicle and plug in the plug for the lighting. Fully retract the support wheel, push the back safety support up, lock and check the lighting. The support wheel may only be unscrewed up to the marking. In the coupled status, the display must be within the green range.



Ball-head open (ready to attach)

## GM10M Pull&Push (switching the second wheel)

The guard master with hydraulic drive can also be operated with two drive wheels. A shut-off valve which you switch as required serves this purpose. This helps you drive in difficult to access terrains.



Shut-off valve points to left → 1 wheel  
Shut-off valve points to right → 2 wheels

## Attachment to a tractor

When attaching to a tractor, you should make sure that no one is between the machine and tractor -> danger of crushing. You must ensure that the upper steering wheel and both lower steering wheels are secured with bolts and folding splints.

When attaching the joint shaft, make sure that it has sufficient overlapping in the pipe profiles.

Furthermore, you must make sure that the securing pins click into the forks! If you do not pay attention to this, there is a risk of fatal injury due to flying parts!

There is also the risk of gearbox damages to the tractor and the machine!

Finally, the plug needs to be plugged in so that the machine has a power supply.

The driver must make sure that the authorised axle loads of the tractor are met.

Furthermore, the driver must ensure that the machine is sufficiently counterbalanced according to the StVO!

If this does not take place, it may be the case that the tractor cannot follow the bends.



Before attachment, it must be checked that the intake bolts for the lower steering wheel are tightened.



### Caution:

When driving the tractor to the wood shredder, no persons may be found between the tractor and wood shredder.

To finish the attachment, the joint shaft is locked on the PTO shaft of the tractor and secured. The PTO shaft is secured against turning with the security chain.

The security chain must be fixed radially to the tractor if possible and have sufficient free length so that the chain do not break when lifting the wood shredder. Pay attention to the correct length of the joint shaft upon initial attachment.





## Drive on Z-machines

The drive of the Z version takes place using the joint shaft from the tractor. It is either directly mounted to the hacking disc shaft (1000 RPM) or to a pre-steering gearbox (540 RPM). All joint shafts are equipped with a freewheel and safety coupling. The freewheel serves the purpose of securing the tractor gearbox (subsequent running of hacking disc) and coupling as a security element for all wood shredders. The joint shaft speed may not be increased above the speed specified on the type label (sticker). For the ZS version, the drive is led through a special double gearbox and the V-belt drive to the hacking disc (maximum drive speed: 540 RPM).



### Caution:

For PTO shaft driven machines with an excessive tractor power, there is the risk of overload. The large tractor motor keeps the speed and therefore the speed of the hacking disc. The ABS cannot react because no reduction in speed occurs and the hacker therefore becomes strained (gearbox damages, drive shaft break). The sliding coupling on the PTO shaft must be set lower in these cases in order to guarantee a reduction in speed. Unfortunately the friction disc loss is also increased by this.

## Pivoting Z-machines (special equipment)

The wood shredder is mounted on a subframe which can be pivoted. This means that the retraction funnel can be pivoted to both sides. After activating the lock on the rotating ring, the wood shredder can be pivoted and locked at distances of 45°. The ejection pipe can be pivoted (see page 25). Attention must be paid that both the wood shredder and the ejection pipe are locked after turning.

## Removing Z-machines

The wood shredder may only be put down on a flat and sturdy ground. The wood shredder can tip over on inclined and soft grounds. After loosening the security chain, the joint shaft is removed from the tractor PTO shaft and placed in the joint shaft holder. The wood shredder is now uncoupled from the 3 point rod.

## Testing the blade and counter blade

A visual inspection of the blade and the counter blade for good condition and checks for a tight fit must be carried out each day before beginning work. Rounded counter blades (lower blade, side blade) and blunt cutting blades have the following consequences:

- a. Increased power requirement = more fuel
- b. Thin branches, twigs etc getting caught
- c. Increased wear of bearings due to the transverse force created.
- d. Risk of cutting equipment breakage
- e. Burning of drive belts
- f. Blockage on the ejection channel due to waste



### Caution:

For work on the hacking disc or on the cutting tools (e.g. blade change), the hacking disc must always be locked with the supplied hacking disc claw. Risk of injury!



## Testing the safety equipment

In addition, a functional test on the safety equipment on the wood shredder must be carried out each day before work.

- Ball joints on the switch equipment may only have a low clearance
- By activating the switch bracket, the functions of the retraction roller must be switched without fail.
- Perfect function of the safety locking on the switch stands
- Off switch on the protective and motor cover (for M version)
- Fixing screw for the protective cover on the hacking disc must be tight
- All cover plates must be tightly attached. Check the screws.

## OPERATION AND IMPLEMENTATION

The wood shredder may only be used outdoors, not inside rooms, due to the danger of poisoning from the drive motor and the wood dust from the wood shredder.

After aligning and stopping the blow-out pipe and the ejection flap (flap position and ejection direction set by operating personnel), the funnel flap is folded down.

### Funnel flap with manual switching

The funnel flap can be folded down after loosening the spring bar (transport security) and removing the folding splint or spring plug. The switch bracket has four switch positions (also refer to the blue sticker).

Pos.1: "Work/FORWARDS" - switch bracket pulled towards operator.

Retraction rollers pull material in!

Pos.2: "Halt/STOP" - switch bracket slid in one step away from the operator. Retraction rollers stay still!

Pos.3: "Reverse/REVERSE" - switch bracket pushed in two steps. Retraction rollers push material back out!

Pos.4: "Safety stop/STOP" - switch bracket fully pushed in!

In the fourth switch position, the switch bracket is tightened (and can no longer be moved).

By additionally raising the release lever (right or left), the switch bracket is pulled back into pos. 1, 2 or 3.



The drive unit can now be switched on and the wood shredder can be taken into operation. Start the motor in idling and slowly increase the speed to approx. 3600 RPM (hacking disc approx. 1000 RPM). Now pull the switch lever towards you. The last click is retraction (working position).

## Funnel flap with electric switching

The funnel flap can be folded down after loosening the spring bar (transport security). The electric switching has four switch positions:

1. Pos. "START" - on the right or left side of the funnel flap, the red pushbutton is activated and retraction starts.
2. Pos. "FORWARDS" - on the right or left side of the funnel flap, the yellow pushbutton is activated and the retraction rollers draw in the material!
3. Pos. "REVERSE" - on the right or left side of the funnel flap, the black pushbutton is activated and the traction rollers push the material back out.
4. "Stop" – press the switch bracket towards the hacker and the retraction rollers stand still.



## Switch bracket setting

The activation force of the switch bracket may be within a range of 0.75 h max. 200N (approx. 20 kg).

The activation force may be max. 150N (approx. 15 kg) in the horizontal part of the switch facility.

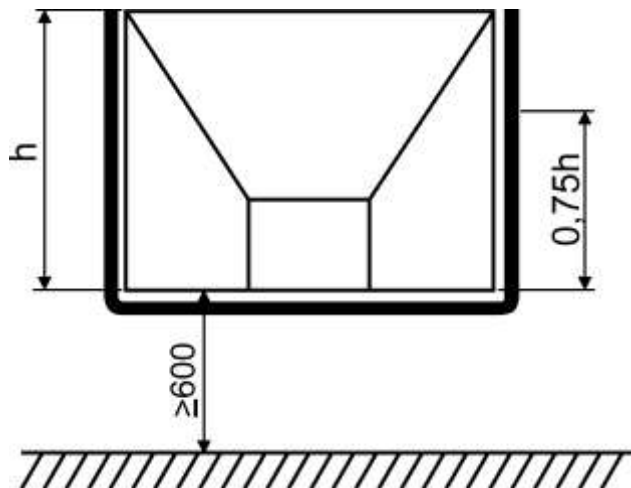

## Bracket force setting

The switching forces listed above must always be complied with. This is to be checked at regular intervals. The switching forces are set on the nut shown on the photo.

The new machines, you must pay extra attention to the correct setting in the first six weeks because the material on the facility needs to be broken in.



## Funnel flap locking

Before any transportation of the machine, the funnel flap needs to be fully clicked in place and secured with a spring connector.



## Material entry and operation

Attention must be paid to solid base for operating personnel!

Place the hacking items onto the base of the funnel and guide the thicker end (trunk) to the retraction roller (taper off thick trunks at the end)

As soon as that have taken the material, step to one side because even as in the trunk can lead to flying particles.

The material is now automatically shredded and pushed in the direction (distance) previously adjusted for the ejection channel.

After entering the material, you should occasionally check the ejection of the chopped wood and possibly readjust the direction of ejection. The width of the ejection is controlled by the ejection flap (see page 20)

When hacking splinters, bark and branches, you can avoid the formation of splinters by guiding the material into the retraction chute next to each other lengthways.

If no more retraction takes place (blockage due to excessive material or branch forks), press the switch lever using "halt" into the "reverse" end position (rollers turn backwards) and the hacked items are pushed back. Now shred the material quantity or saw off branch forks and start loading again.

If the drive power is currently too low (motor speed reduces heavily), briefly switch off the retraction (bring switch bracket into the "halt" position) until a motor speed has reached the working speed again then set the switch lever back to "forwards" (work) (the special equipment ABS system regulates this automatically). Once work has ended, switch off the drive motor and lock the switch bracket. The funnel can only be cleaned with suitable aids made of wood. Now the funnel extension is folded in and secured with the spring bar. To finish, place the ejection to the back in the direction of travel and take off the parking supports.



### Caution:

The wood shredder can only be operated with the retraction flat folded down!

Do not reach into the funnel when the machine is running! Push small pieces of wood through using a wooden stick or pusher if necessary! Never push the hacked material through the funnel with a metal rod or metal pusher! It is also forbidden to remain in the danger zone! With particularly strong or hard wood, it makes sense, depending on the tractor power, to briefly set the drive motor to "halt" if the speed drops so that the motor can achieve the nominal speed again.

## Operation

A steady base is to be ensured before initialisation (place any brake wedges in front of the wheels and slide out any additional supports).

Before beginning work with motor machines, it must be ensured that the hacker is in a horizontal position and therefore that the minimum height of the funnel flap (and lower edge) does not fall short.

After aligning and locking the blowout pipe and the ejection flap; (flap position and ejection direction away from the operating personnel), the funnel extension is folded down. The safety shaft must be activated so that the switch rod is released.

The drive motor is now started and set to a maximum working speed (pay attention to the motor operating manual). The hacking material can now be entered.



## Noise emissions

The wood shredder produces a guaranteed sound level in accordance with directive 2000/14/EC of:

Type	Sound level LWA [dB]	Sound pressure level LAeq [dB(A)]
GM10M or WS 10-14 SP	113	82,1
150M or WS 15-27 P	115	107,8
170M	115	107,8
190M or WS 18-35 D	117	112
250M or WS 18-35 DT	115	107,8
350M	119	111,4
450M	121	112,3
550M	122	113,1

Due to the high noise emissions of the wood shredder at work, ear protectors must be worn. (See sticker on wood shredder)



## Blockages

The cover may only be opened and stuck pieces of wood removed with a suitable tool in the event of blockages around the retraction channel when the great disc has come to a standstill and the drive motor switched off. The hacking disc must be locked in position! You must make sure that the cover cannot close independently. Before opening the cover, the blowout pipe must be locked in a direction away from the cover. Close the side cladding and the cover tight again after addressing the blockage.



## Transport position

First of all, the switch bracket is brought into the "halt" end position. With the safety lock beneath the funnel flap, the switch rod is automatically blocked on the "halt" position by turning the safety shaft by approx. 45°. Turn the blowout pipe to the back in the transport position.

## Cleaning the machine

The machine is to be cleaned after finishing work each day. The side cover on the wood shredder must be folded up for this. Loose chips and little twigs are to be removed and blade slits on the hacking disc must be cleaned. The hacking disc must be locked. This preserves the machine and increases the service life.





## ABS System

The ABS system is an automatic overload protection. The actual speed of the hacking disc is measured on the hacking disc shaft. If this falls below a specified value, the retraction rollers automatically switch off. The drive motor can now recover. If the target speed is achieved again, the retraction rollers automatically switch again. The switch-off and switch-on speed can be set by your workshop.



## Maintenance and repair

All machines are test driven before they leave the factory. The hydraulic tank is filled with hydraulic oil up to the top mark of the sight glass before delivery. After 50 operating hours, the filter must be changed. Changes are made after this in accordance with the maintenance schedule. The first inspection is part of the warranty condition. Only trained personnel may be deployed for maintenance and repair work. The enclosed motor manufacturer's operating manual is to be taken into account for motor maintenance.



### Caution:

The pressure limitation valve is set in the factory and may not be adjusted. The maximum operating pressure of the hydraulic system is stated in the below table or please refer to the type label.

Type	Operating pressure
GM10 or WS 10-14	180 bar
150M	190 bar
170M/Z or WS 15 PTO	190 bar
190M/Z or WS 18-35 D / PTO	190 bar
250M or WS 18-35 DT	190 bar
327Z or WS 20 PTO	190 bar
350ME/MT	190 bar
431Z or WS 23 PTO/S/ZSA	190 bar
450M	190 bar
532Z/ZS/ZSA	190 bar
550M	190 bar

Upon delivery, the bearings are ready lubricated and the gearbox filled with oil. However it recommended that you check before initialisation. For all couplings, gears, oil motors and V-belt drives etc upon mounting, attention must be paid that these are level and parallel to each other. For all parts to be mounted, attention is to be paid to the general machine construction. Check all safety covers for a tight fit after maintenance and repair.



### Caution:

If your machine is filled with bio-diesel, shorten all maintenance intervals of the motor by half.

## Maintenance for wood shredders

	Measure	Interval
1. Bearings on hacking disc shaft	Grease change in bearing;	Annually
	Visual check and possible adjustment of the bearing; balls should have 0.03 mm clearance (measured between ball and outer ring)	Daily
	Lubrication	Every 50 hours
2. Bearing of retraction roller	Test, replace if necessary	Daily
	Lubrication	Every 50 hours
3. Cardan shaft joint and profile pipe (Z-machine)	Lubrication	Every 8 hours
4. Gearbox (Z-machine)	Check oil level	Daily
	Change oil	Annually
5. Hydraulic system	Oil change and tank cleaning	Every 2 years
	First filter change	After 50 operating hours
	First filter change	Every 500 operating hours
6. Upper retraction	Abschmieren	Every 8 hours
7. Cooler grate, perforated motor cover	Cleaning	Daily
		In motor direction for ejection: hourly

Lubrication grease: long-term grease EP2

Gearbox oil: SAE 85 W 90

Hydraulic oil: HVI46

**Caution:**

Before setting, cleaning and maintenance work is carried out, the drive needs to be uncoupled and the tools brought to a standstill.

**Caution:**

All covers must be mounted tightly after all maintenance and repair work, and all safety equipment must be tested for function! Only original tested parts are to be used for repair work!

**Caution:**

Should your machine be filled with bio-diesel, shorten all motor maintenance intervals by half.

**Caution:**

1. For longer standing periods, the batteries should be charged at least every 3 months and before delivery of the machine.
2. Start intervals for working time length should be complied with so that the battery can be regenerated accordingly.
3. In order to make sure that the battery is not overloaded (possible with older models), a battery maintenance charger should be used.

## Checking the screws

After approximately 2-5 operating hours, all fixing screws are to be checked for a tight fit. Furthermore, the fit of the screws and nuts should be checked at regular intervals (daily).

## Ball bearings

The ball bearings on the retraction rollers and hacking disc shaft are to be lubricated according to the maintenance table. The ball bearings are to be tested at least once per year and replaced if necessary.

## V-belts

All V-belts are to be checked for the first time after 4 operating hours for tension and tightened if necessary. Furthermore, weekly checks on the belts must be performed. When purchasing the belts, attention must be paid to set accuracies i.e. the V-belts may only be purchased as a set.



The cutting blades are dismantled by loosening the screws, pos. 4. These must be retightened after changing.

The cutting blades are made of special steel and may not be welded. The cutting blades may only be changed by inducted personnel.

After grinding, attention must be paid that the blades are completely smooth and even. Any remaining grinding burrs are removed by honing.

Please pay attention to the following grinding instructions! (See page 41)



4

Notched blades give a poor chipping quality and retraction is difficult meaning that the blades are quickly blunt.

When attaching the blades, the gap between the blade and counterblade must be readjusted.

Fibres or uneven chips are produced due to larger gap and more power is required. If the gap is smaller than 1 mm, the blade can hit the counterblade during operation.

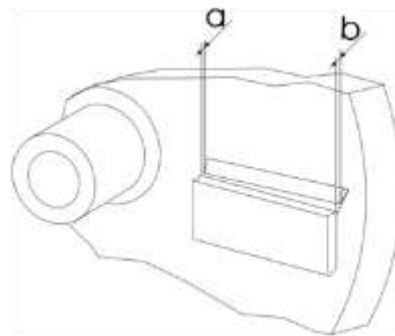

**Caution:**

Never weld the worn hacking blade.



**Caution:**

The torque of the blade screws (rotating - fixed blade) is 221 Nm (approx. 242mkp)

Type	Size a [mm]	Size b [mm]
GM10M/Z or WS 10-14 P/SP/PTO	1	1
150M or WS 15-27 P	1	2
170M/Z or WS 15 PTO	1	2
190M/Z or WS 18-35 D / PTO	1	2
250M or WS 18-35 DT	1	2
327Z/ZS/ZSA or WS 20 PTO	1	2
350ME/MT	1	2
431Z/ZS/ZSA	1	2
450M	1	2
532Z	1	2
550M	1	2

## Hacking blades and counterblades

Hacking blades and counterblades are to be checked each day before initialisation for the optimum setting and condition. Blunt blades and counterblades have a huge force requirement. They cause very high drive belt wear. The bearings are overloaded and the fuel consumption increases.

The hacking disc is equipped with two hacking blades as standard. These always cut down the supplied hacking product into discs. The special arrangement of the blades breaks down the cut-off discs. The hacking blades need to be ground or changed as soon as they look blunt or retraction becomes difficult (i.e. the blade pushes the wood back). The subsequent running of the hacking disc must be considered when opening the cover.

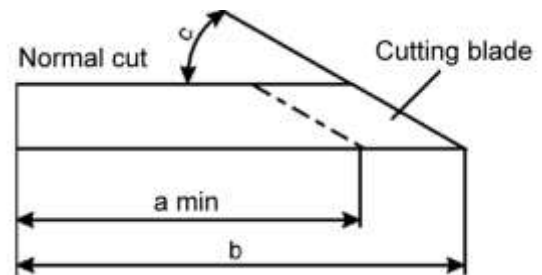

**Caution:**

The blade may only be changed by induced persons.



**Caution:**

Before setting, cleaning and maintenance work is performed, the drive must be uncoupled and the tools brought to a standstill.

For work on the hacking disc or on the cutting tools (e.g. blade change), the hacking disc must always be locked with the supplied hacking disc claw.

Risk of injury! The manufacturer and max. speed are shown on the tool support.

Type	Size a [mm]	Size b [mm]	Size c [°]
GM10M/Z or WS 10-14 P/SP/PTO	85	95	30
150M or WS 15-27 P	80	95	30
170M/Z or WS 15 PTO	80	95	30
190M/Z or WS 18-35 D / PTO	80	100	30
250M or WS 18-35 DT	80	100	30
327Z/ZS/ZSA or WS 20 PTO	80	100	30
350ME/MT	80	100	30
431Z/ZS/ZSA	110	125	30
450M	110	125	30
532Z	110	125	30
550M	110	125	30

If the hacking quality drops, the condition of the cutting blade and the counterblade must be checked.

As soon as the impact edge of the counterblade has a larger radius than 1 mm, this should be turned over or replaced. The actual counterblade can be turned and used from four sides. In contrast to the cutting blade, it cannot be resharpened.

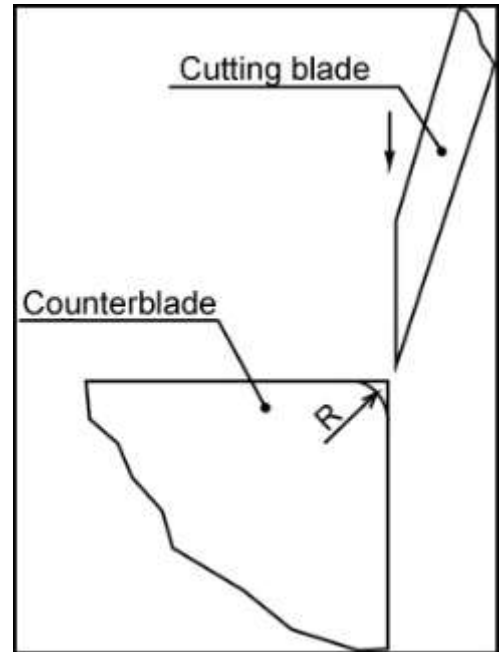

In order to loosen the counterblade, the retainer on the side of the housing must be loosened. The counterblade is found behind and can be turned or replaced.

There is a thread in the counterblade which facilitates removal with a screw.

The large cover must be removed first on the vertical counterblade. Both traction springs are then released and the top carriage is folded up and secured. The cover screws are then loosened on the left side.

The cover must be folded up. The screws on the vertical counterblade must now be loosened and the blade pulled out.





## Grinding instructions

The material is a so-called air hardener which means that if the blade becomes hot, due to grinding for example, the material hardens in the air without quenching - the cutting tip becomes very hard which can lead to breakages. Therefore attention must be paid to the following:

1. A soft, open grinding stone to match the grinding machine and the material to be ground.
2. A steady grinding machine free of vibrations
3. Grind directly at the grinding point (wet grinding) with strong cooling
4. Set the correct angle (30°)
5. You should hand over these grinding instructions to your tool grinder or customer

## Lubrication plan

TS GM 10 M Pull & Push or WS 10-14 SP



**TS GM 10 M 80km/h or WS 10-14 P**



TS 150 M or WS 15-27 P



TS 170 / 190 M or WS 18-35 D



TS 250 M or WS 18-35 DT

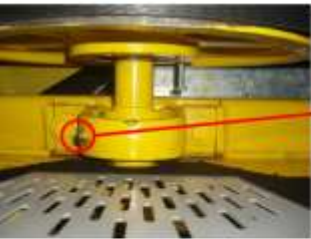

# TS 350 / 450 M







**Z-machines**

**GM10Z or WS 10 PTO**



**170Z or WS 15 PTO**

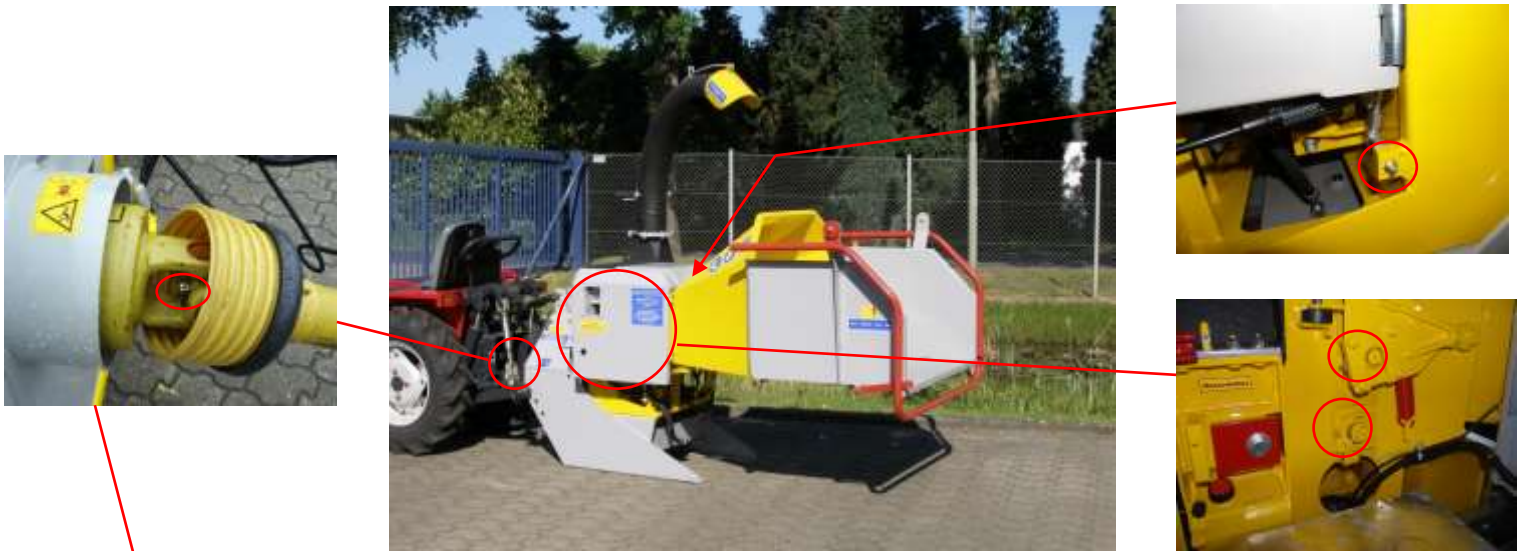

**190Z or WS 18 PTO / 327Z or WS 20 PTO / 431Z or WS 23 PTO / 532Z**

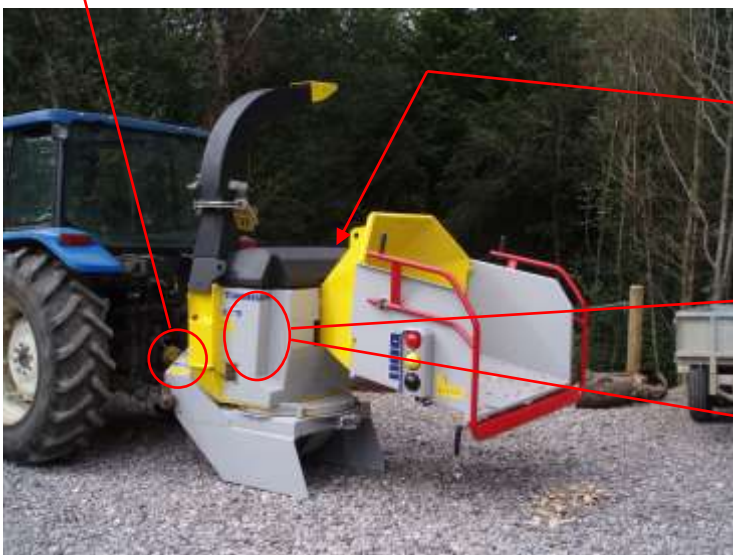

## CONTROL ELEMENT OF THE KUBOTA ENGINE

- A: Green warning light - operating control light (OK)
- B: Warning light battery charge control
- C: Warning light oil pressure
- D: Warning light coolant temperature
- E: Preheating light (8 seconds)
- F: Ignition lock

In case of a defect, the engine is automatically shut off, and the warning lights C and D light up.

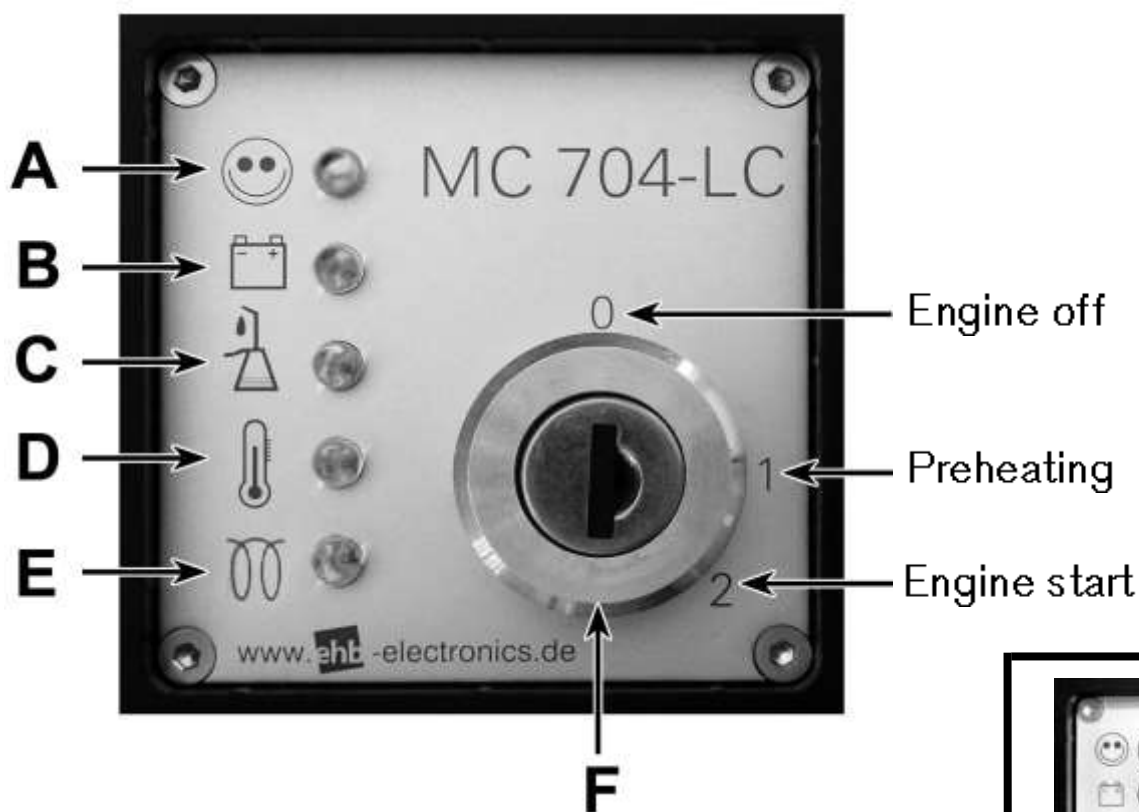

Do not put the contact key on a heavy bunch of keys, this might produce disconnection of the ignition during the operation.



# HMC 542

## General

The hacker and motor control HMC 542 contains, as well as the automatic control for the retraction rollers of a wood shredder, complete monitoring of the diesel motor and an ignition start switch.

Speed measurement device and a day and total operating hours counter are also integrated.

The differentiation is made between two different operating statuses when operating the HMC 542:

## Programming the parameters

This is to be understood as the setting of various base values to adapt the HMC 542 two different hacker types.

Programming the parameters is only necessary upon first initialisation. These settings can also be made in the factory on request.

## Normal operation

The HMC542 has a display function in the normal mode. Depending on whether the blade shaft turns or not, either the speed or the total operating hours is displayed. Before the HMC 542 can be used, the basic parameter settings must be made. The individual parameters with their names (these appear on the display) as well as their meanings are listed on the following page.



## HMC 542 view

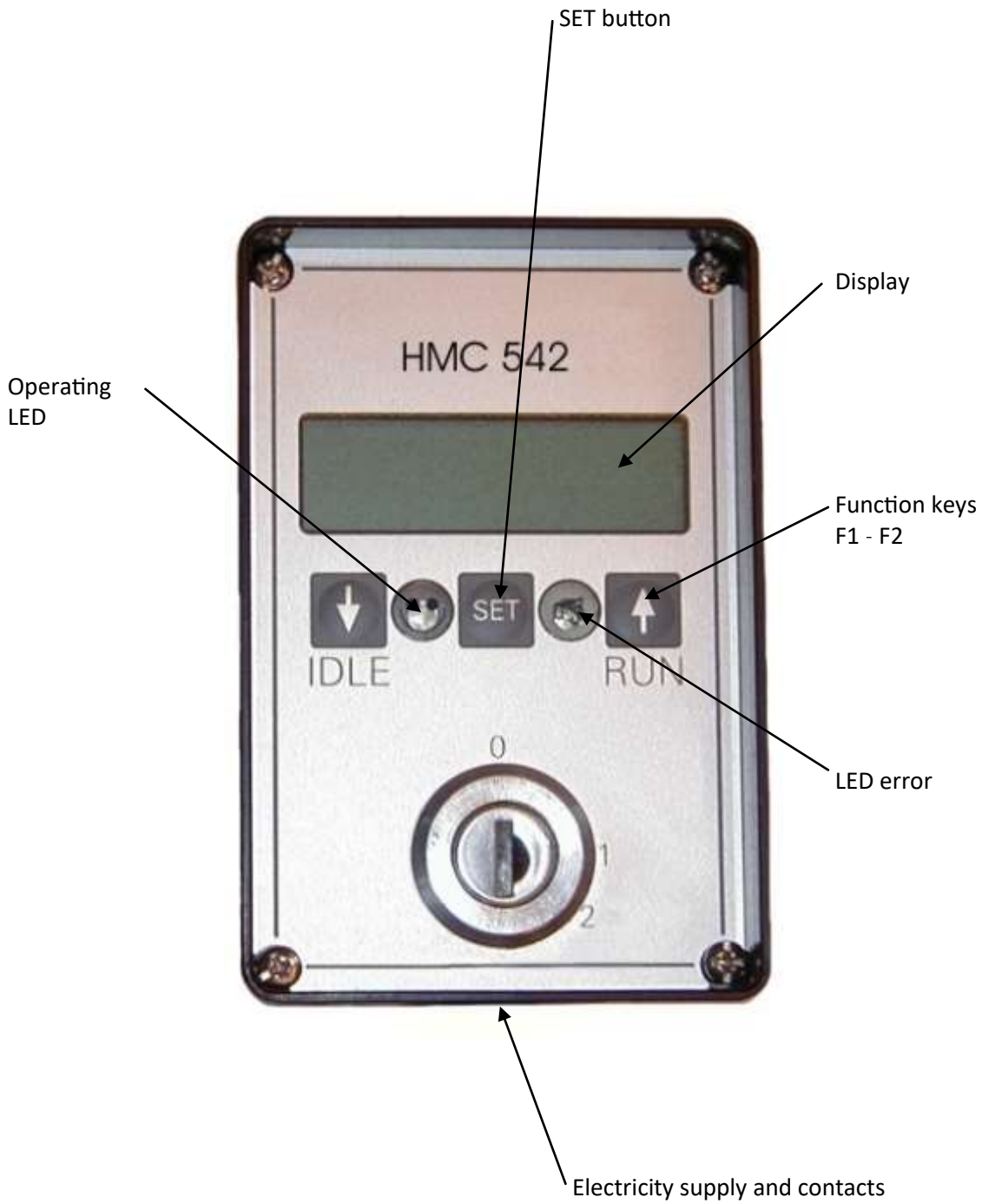

## Key functions

Key

Meaning



Display of the selected operating values; switch off of flashing error LED.  
Confirmation button for parameterisation



Green operating LED:  
Illuminates when the device is in operation, flashes during the preheating process



Red error LED:  
Flashes when an error has occurred



Function key F1:  
Previous display  
Reduces value and number



Function key F2:  
Next display  
Increases value and number



Display with 16 digits in two lines

## Software

When starting the device, the software version number appears on the display for approximately 2 seconds:

e.g.

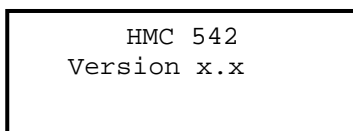

Always keep your software version number to hand for any questions on the HMC 542.

# HC 960

## General

The hacker and motor control HC960 contains, as well as the automatic control for the retraction rollers of a wood shredder, a speed measurement device and a day and total operating hours counter. The differentiation is made between two different operating statuses when operating the HC960:

## Technical data

Dimensions:	80 x 80 x 75mm
Display:	LCD, 4-digit, 13mm
Operating voltage:	8...30V
Power consumption:	max. 100 mA
Output load:	max. 6A
Temperature range:	-25...85°C
Total operating hours counter:	0... 9999 h
Day operating hours counter:	0...99:99 h
Speed measurement:	1...2700 rpm
Pulses per rotation:	1...255
Lower speed limit value:	0...99% of the normal speed
Switch-on speed:	0...99% of the normal speed



# AMP plug

## Pin allocation HC 960 with 6 pole AMP plug (CON-6)

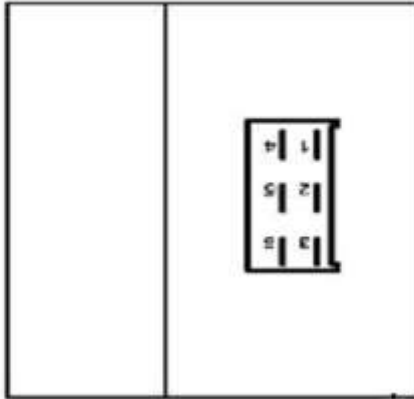

- PIN 1 - initiator impulses
- PIN 2 - magnetic valve +
- PIN 3 - magnetic valve -, initiator -
- PIN 4 - initiator +
- PIN 5 - battery +
- PIN 6 - battery -

- Inductive transmitter (PNP) - Brown - PIN 4
- Black - PIN 1
- Blue - PIN 3

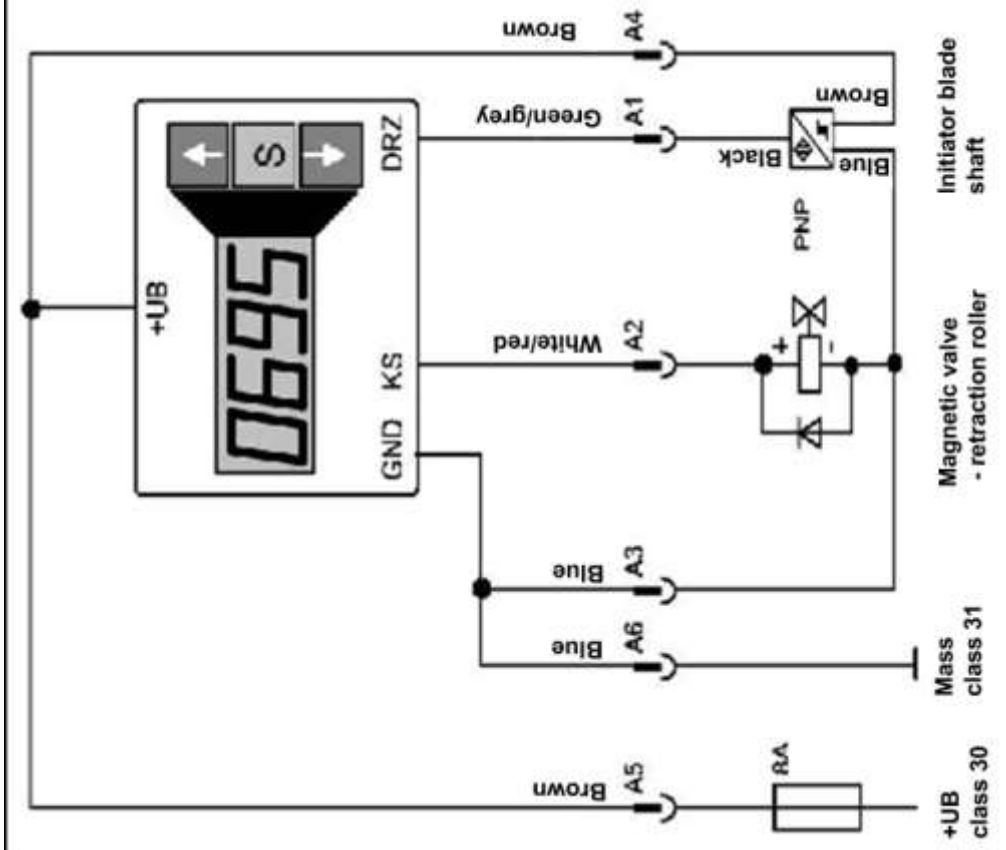

# Description and manipulation

## PILOT SYSTEM

### Available Functions

1. Permanent display of the engine RPM
2. Permanent display of the rotor RPM
3. Permanent display of the total daily hours
4. Permanent display of the total machine hours
5. Green LED indicates that the engine and rotor are turning
6. Red LED indicates fault
7. Hydraulic Test: a rapid forward and reverse action to test the correct function of the hydraulic circuit
8. A rapid forward action of the rotor to test intervention of the NoStress facility
9. 3 NoStress (VarioStress) choices relative to the type of material to be processed
10. Maintenance management : intervals for oil change
11. Belt slippage, clutch and hydraulic coupling security system
12. Engine cut-out and starter motor deactivation security system (housing sensors)
13. Default memory settings
14. 21 machine types programmed into memory
15. 4 language options available : English, French, German and Spanish





## Description and manipulation

### Description of box

#### Led :

- Green - static: on
- Green - flashing: indicates impulsions given by the rotor sensor
- Red - static: indicates that engine and/or rotor housing is open

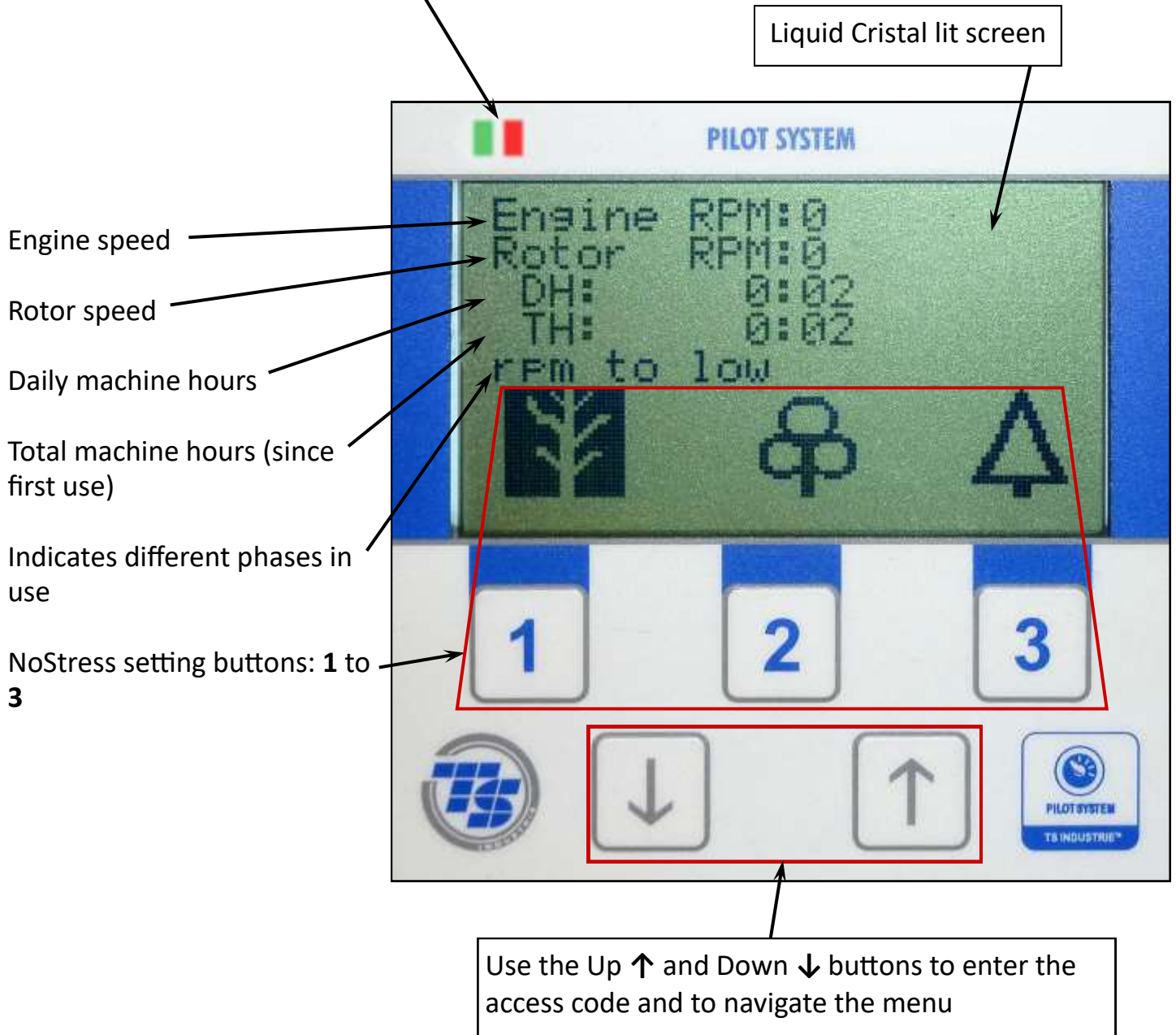

**It is formally forbidden to modify the default factory settings of the Pilot System. Any modification to the security and program parameters made outside of our factories is the entire responsibility of the person having made these changes.**

## Description and manipulation

### Choice of NoStress setting

As with the **VarioStress**, the **Pilot System** has 3 settings.

Above each button is a liquid crystal pictogram representing the setting.

**Button 1** for branch waste: uses a wider engine RPM.

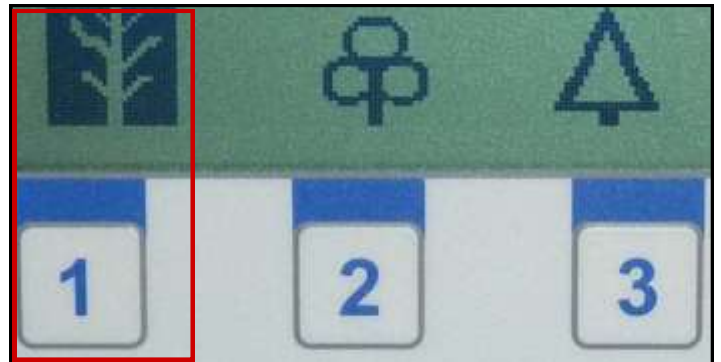

**Button 2** for leafy waste: uses an intermediate RPM. Can be used for branch waste and small amounts of conifer/vegetation.

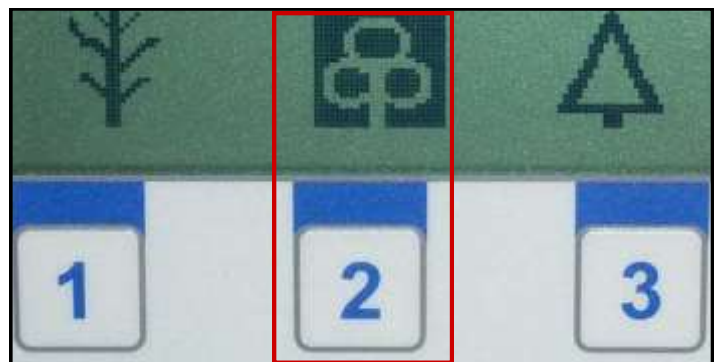

**Button 3** for conifer and large quantities of vegetation (particularly wet and green wood): restricted but high regime for maximum ventilation.

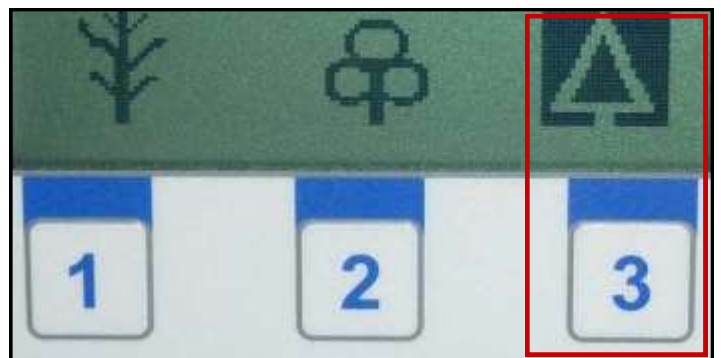

If the programme settings are changed during use, the yellow forward button must be pressed to reengage the feed rollers.

## Description and manipulation

### Normal and high speed function

The rotor speed is indicative of the functioning on the machine.

The message **RPM too low** indicates that the engine RPM, and consequentially, the rotor speed, is not sufficient to allow the forward feed action of the feed rollers.

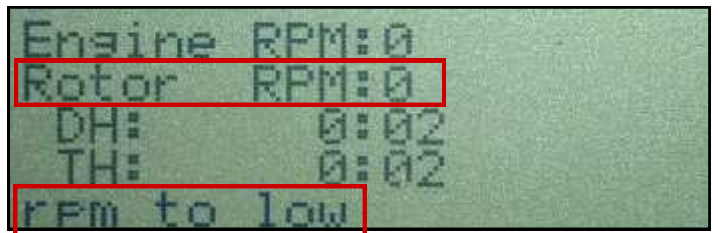

Increase the engine speed to maximum: a **smiley** indicates when the minimum rotor speed for forward feed action has been reached. The **Yellow forward button** can now be pressed.

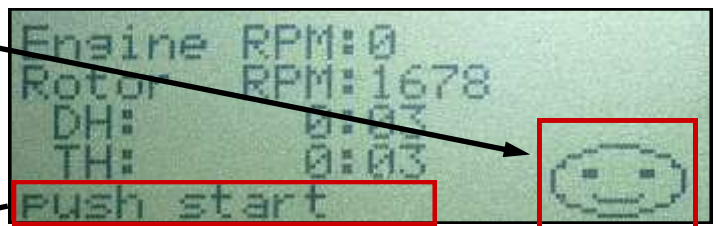

Once the feed rollers are in action, if the red stop bar to the rear of the hopper is pushed, **feeder stop** is displayed.

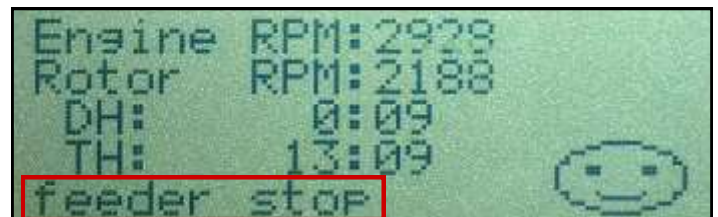

If the rotor speed is too high, the feed roller is automatically stopped to prevent use of the machine and a **Danger** symbol is displayed along with the message **Rotor over speed**.

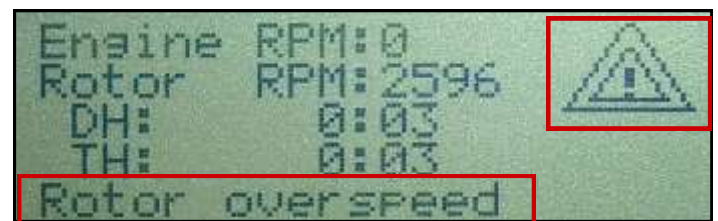

To restart the rotation of the feed rollers, the engine must be slowed. It can be returned to maximum only once the cause of the over speed has been rectified.

## Description and manipulation

### SLIPPAGE function

The Pilot system controls any slippage in the rotor transmission by permanently comparing the speed of the engine pulley in relation to the rotor pulley. A percentage slippage is tolerated in order to protect the transmission (belts, centrifugal clutch or hydraulic coupler). If the slippage is greater than the allocated percentage, the engine is stopped and a message is displayed on the screen.

#### Different causes of slippage:

- rotor blocked at start-up or during operation
- belts loose
- clutch worn

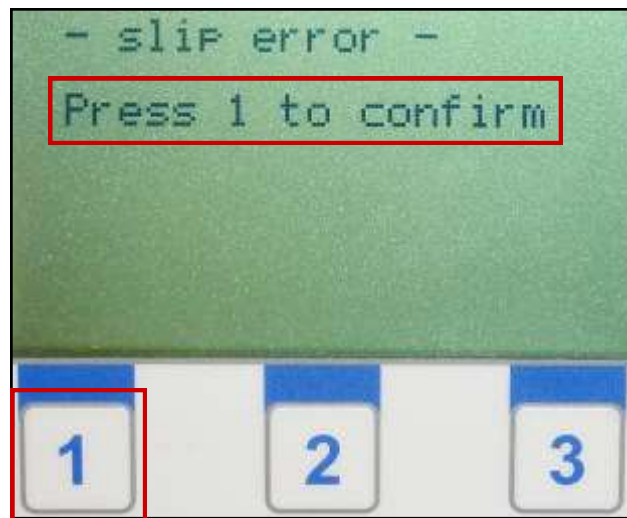

**N.B.:** Slippage can also occur if the machine is accelerated very slowly from standby.

To bypass the message and continue, press the button **1** after having verified and controlled the transmission.

The date and time of this message are recorded and saved in the memory of the Pilot System and can be consulted by the mechanic or dealer.

## Access to CLIENT parameters

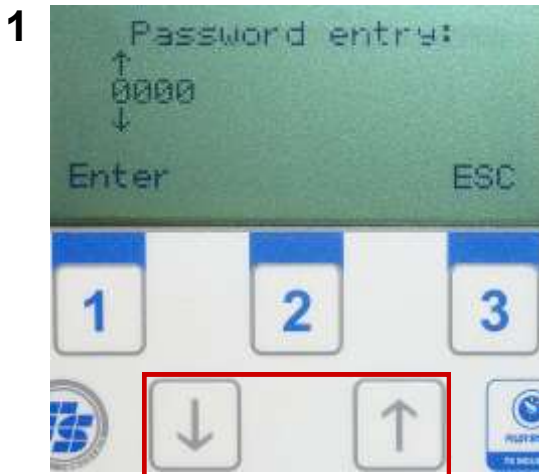

Hold down the ↓ and ↑ buttons for 4 seconds

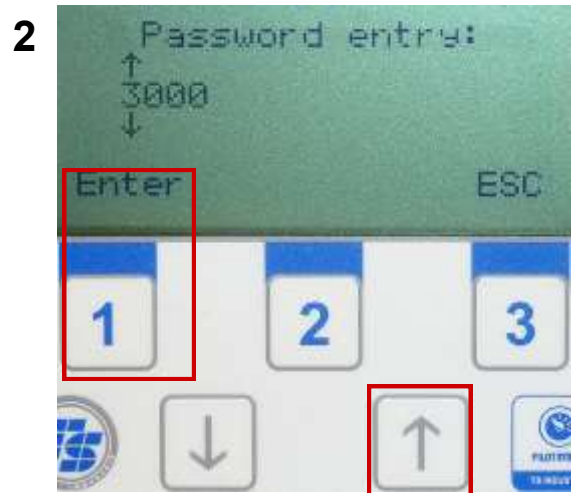

Press the ↑ button 3 times to enter number 3, then validate by pressing 1

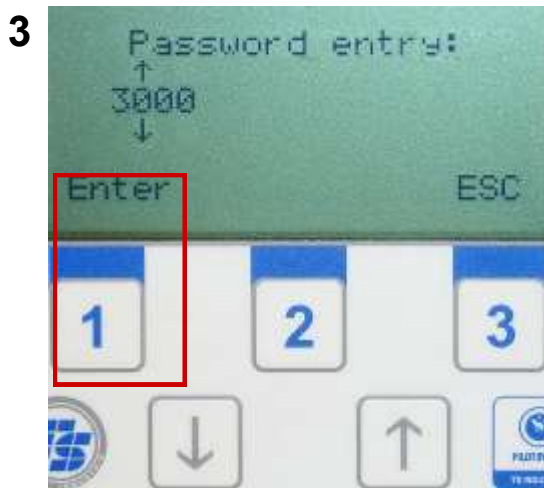

Press the button 1 to validate and bypass the number 0

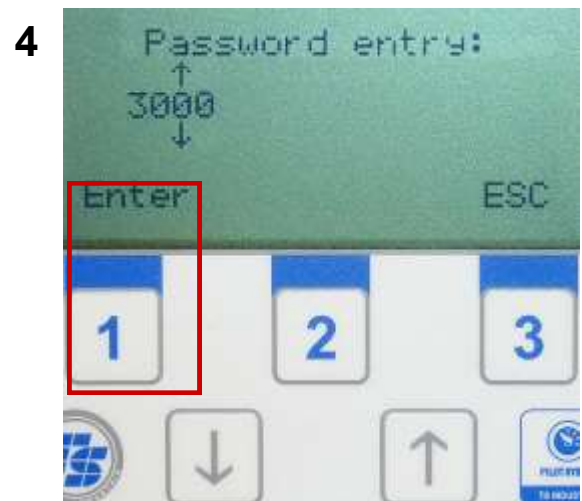

Press again on the button 1 to validate and bypass the second 0

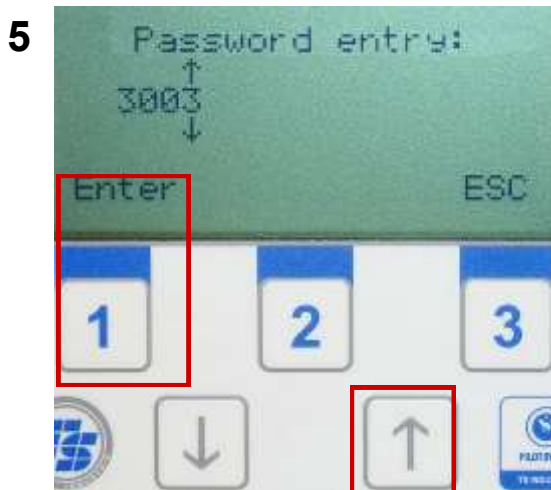

Press the ↑ button to enter number 3 et valider avec la touche 1

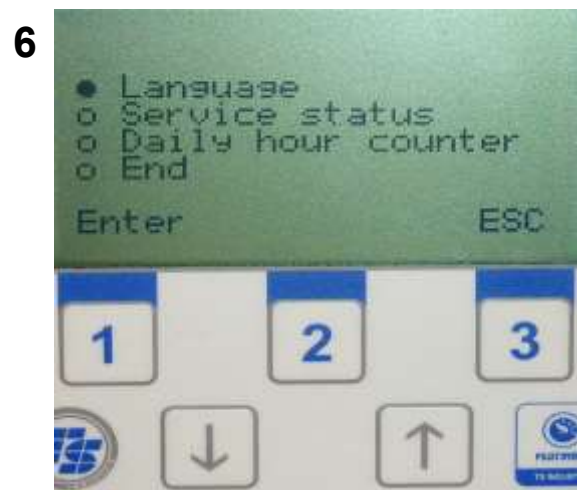

The user can now access the menus **Language**, **Daily Hour counter**, **Service Status** (services and oil change) and **END** navigation

## Description and manipulation

### Resetting the Daily Hour counter

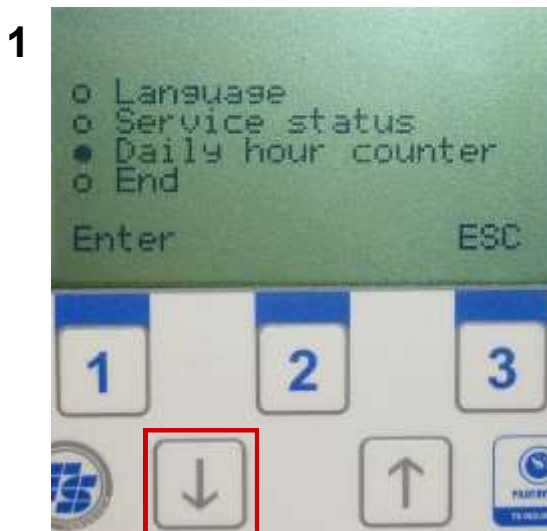

Press ↓ to scroll to the **Daily Hour Counter**

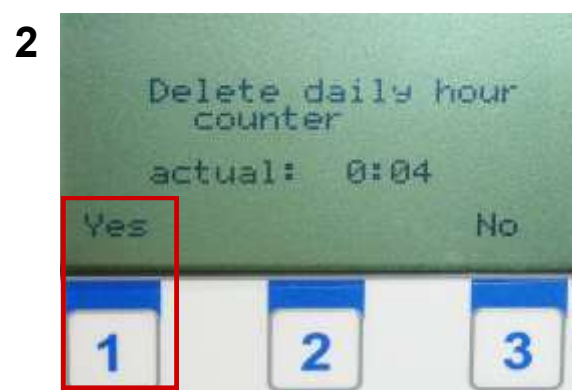

Press **1** to validate the deleting of existing hours

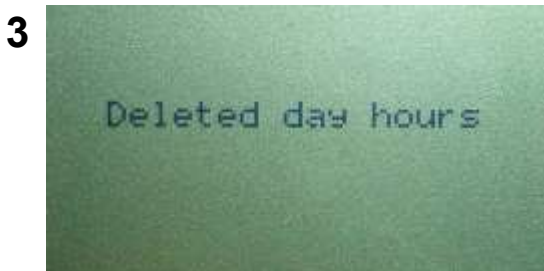

A message validates the operation

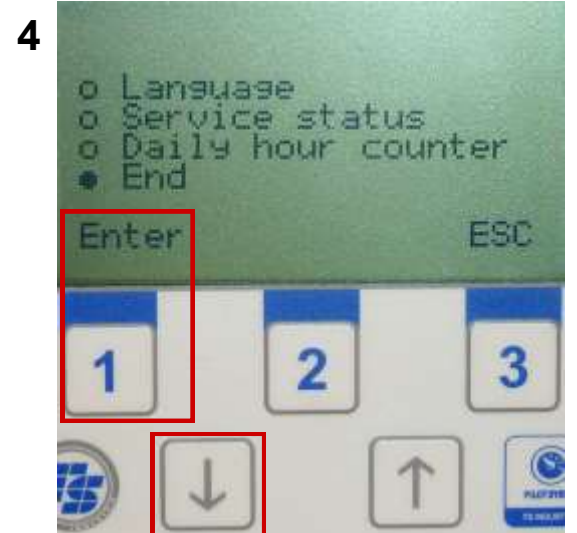

Press ↓ to scroll to **END** and press **1 Enter**

## Description and manipulation

### Service overdue and next service information (engine oil change)

When the service is due or overdue, a warning message and an icon show when the machine is turned on.



Organise a service with your dealer to carry out the oil change. The message is saved in the Pilot System. To bypass the message and continue work, press the button **1**.



Press once or twice on the ↓ or ↑ buttons at any time to visualise the next oil change or service, then contact your dealer in advance to make a reservation.

## Description and manipulation

### NoStress rotor settings selected

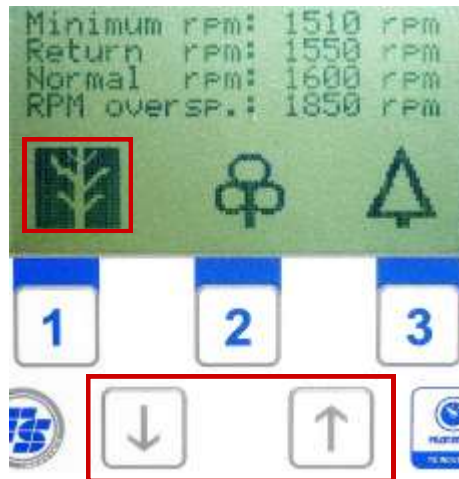

Press the ↓ or ↑ buttons once or twice at any time to visualise the rotor settings for the selected NoStress option:

Example option 1 below:

**Minimum RPM:** below 1875 rpm the feed roller stops.

**Return RPM:** from 2175 rpm, the feed roller starts to turn.

**Normal RPM:** after over-speed of the engine or rotor (PTO), the rotor must return to less than 2175 rpm in order that the feed roller can function again.

**RPM overspeed:** rotor stops.

#### REMINDER:



It is formally forbidden to modify the default factory settings of the Pilot System. Any modification to the security and program parameters made outside of our factories is the entire responsibility of the person having made these changes.



## Description and manipulation

### Rotor access security (ER and DR) and engine housing open (DR)

A **red LED** and a warning message indicate that the rotor access or engine housing is open or has not been correctly closed. The security system stops the engine and prevents restarting (deactivates starter motor). To delete this message, ensure that the housings are closed and press the button **1**.



### Rotor rotation impulse sensor

A static **green LED** indicates that the machine and, consequently, the Pilot System, have been turned on. The light begins to flash when it receives a signal from the **rotor impulse sensor M18**. The frequency of the flash varies with the speed of the rotor.



## Bio hydraulic oil

Filling the machines with  
"BIO" hydraulic oil HE46 BIO

First filter change the same as HVI oils.

Filter change the same as HVI oils but at least once per year.

Condensation escape by releasing the drainage screw each month.

For temperatures between -10° and 25°, allow the machine to warm up for several minutes with the retraction switched on.

HE 46 BIO oil can be mixed with other BIO oils on a rapeseed oil basis that correspond with DIN 51524 part 2.

Filling with HE46 BIO from used machines that previously had hydraulic oil on a mineral oil basis.  
See appendix!

# Hydraulic plans

## Wood shredder with ABS

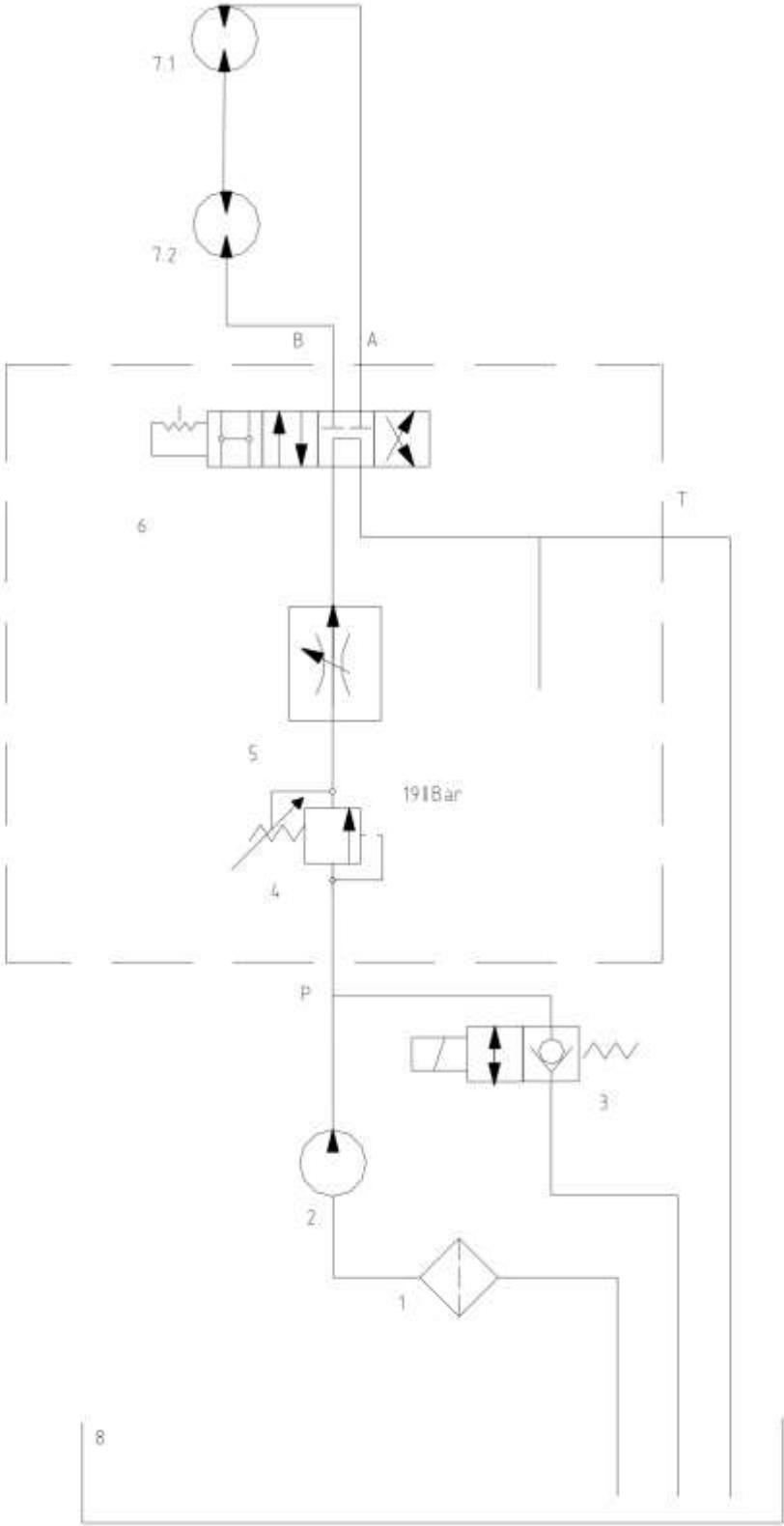

Wood shredder with ABS + EPS

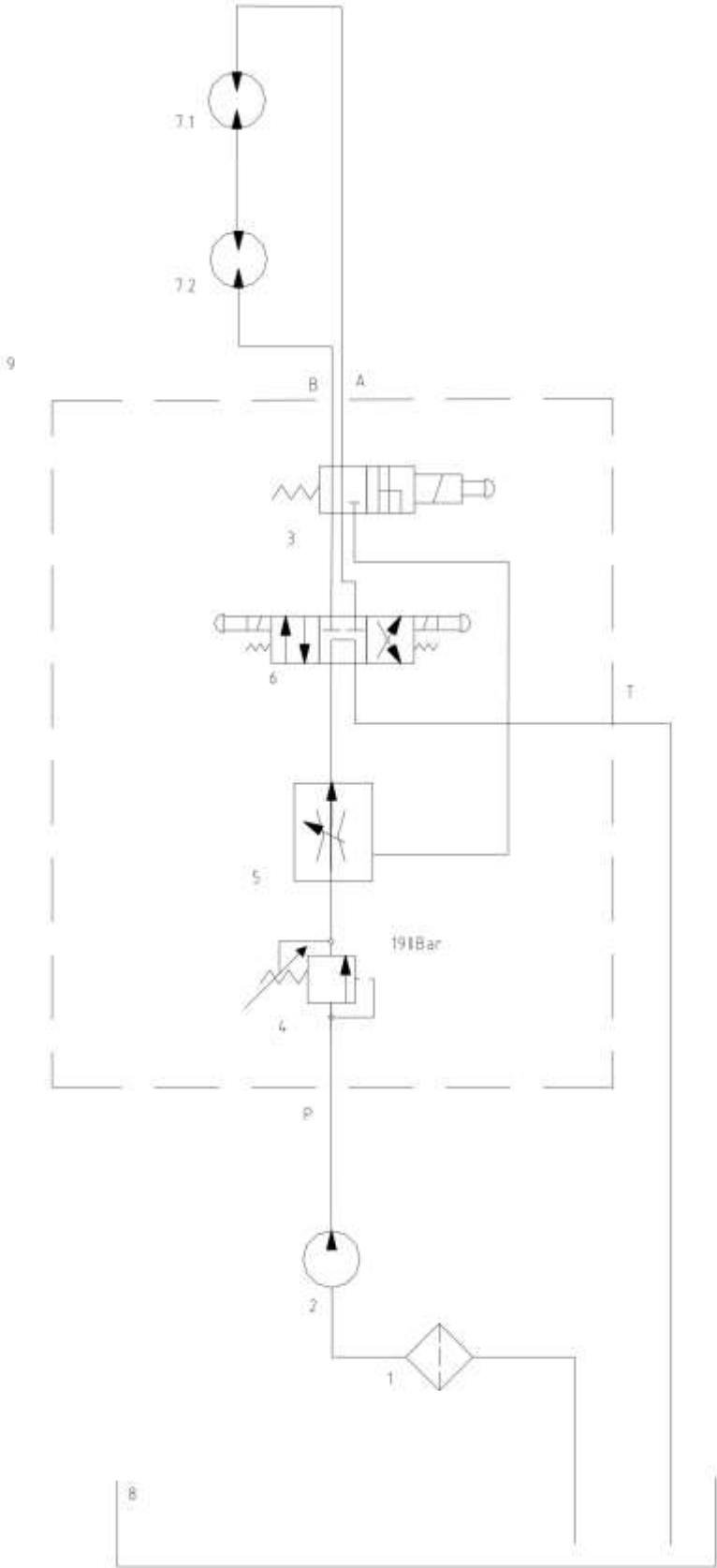

# GM10 Pull&Push

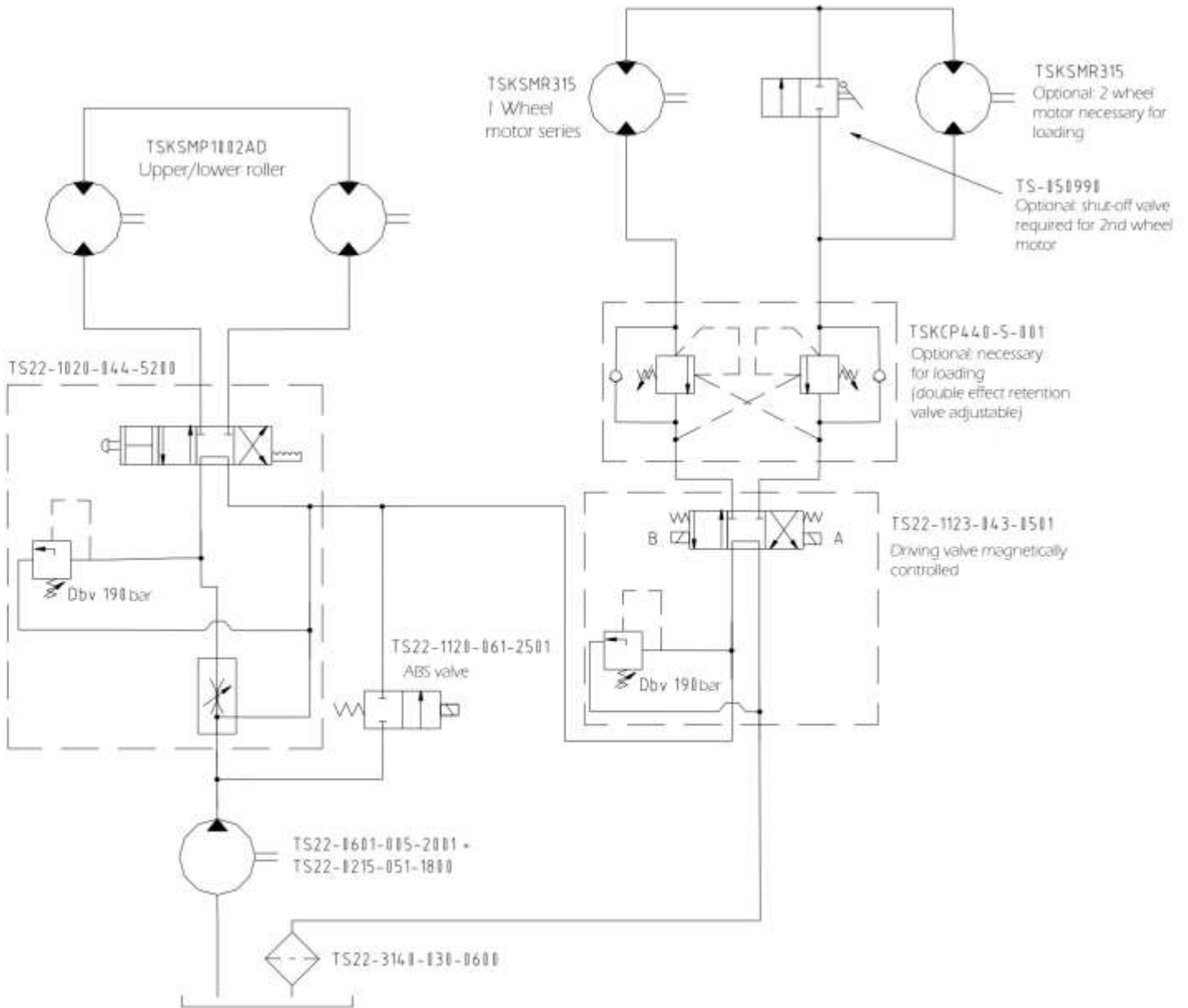

# Electrical diagrams

170M / 190M / 250M

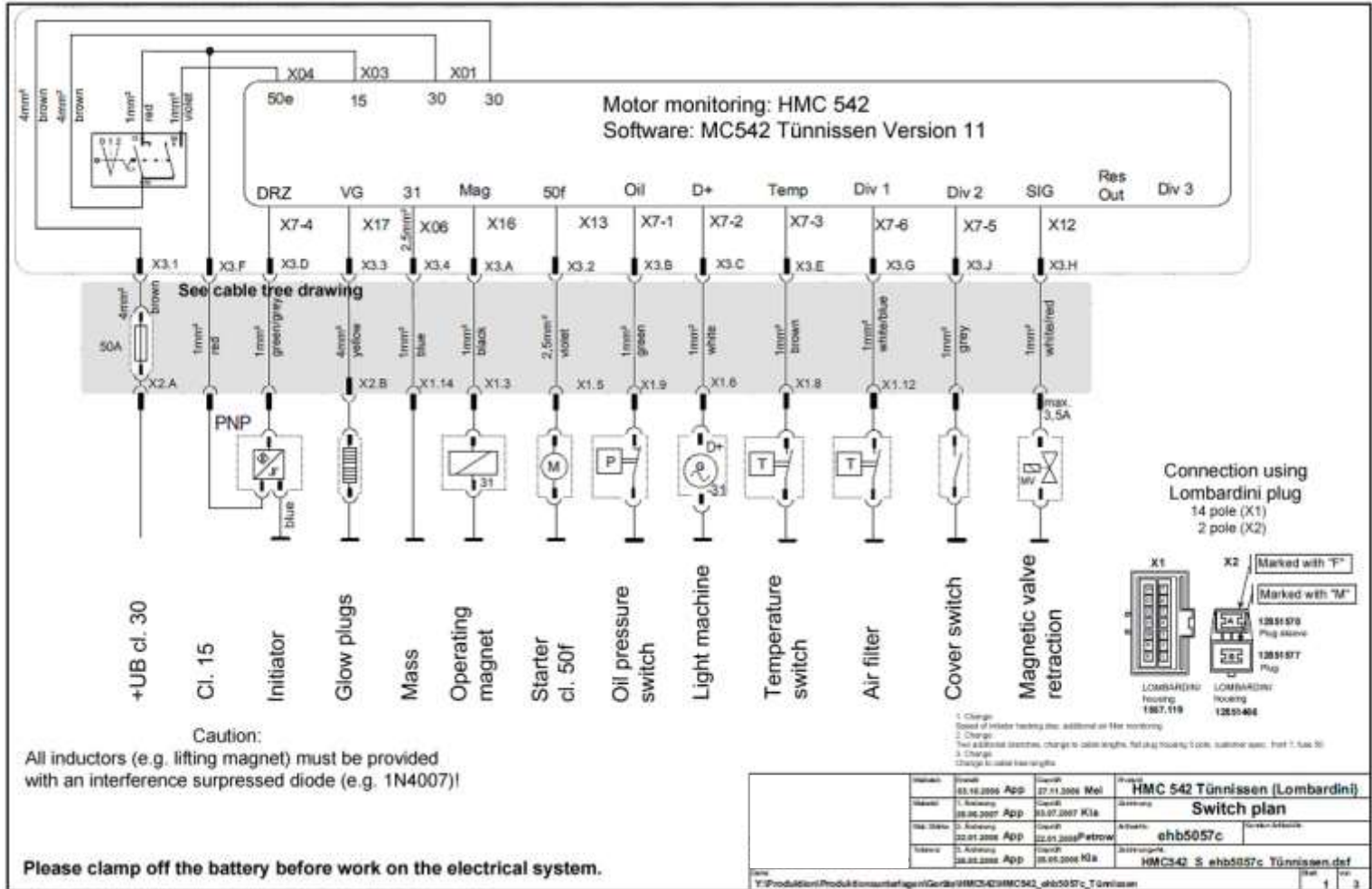

Please clamp off the battery before work on the electrical system.

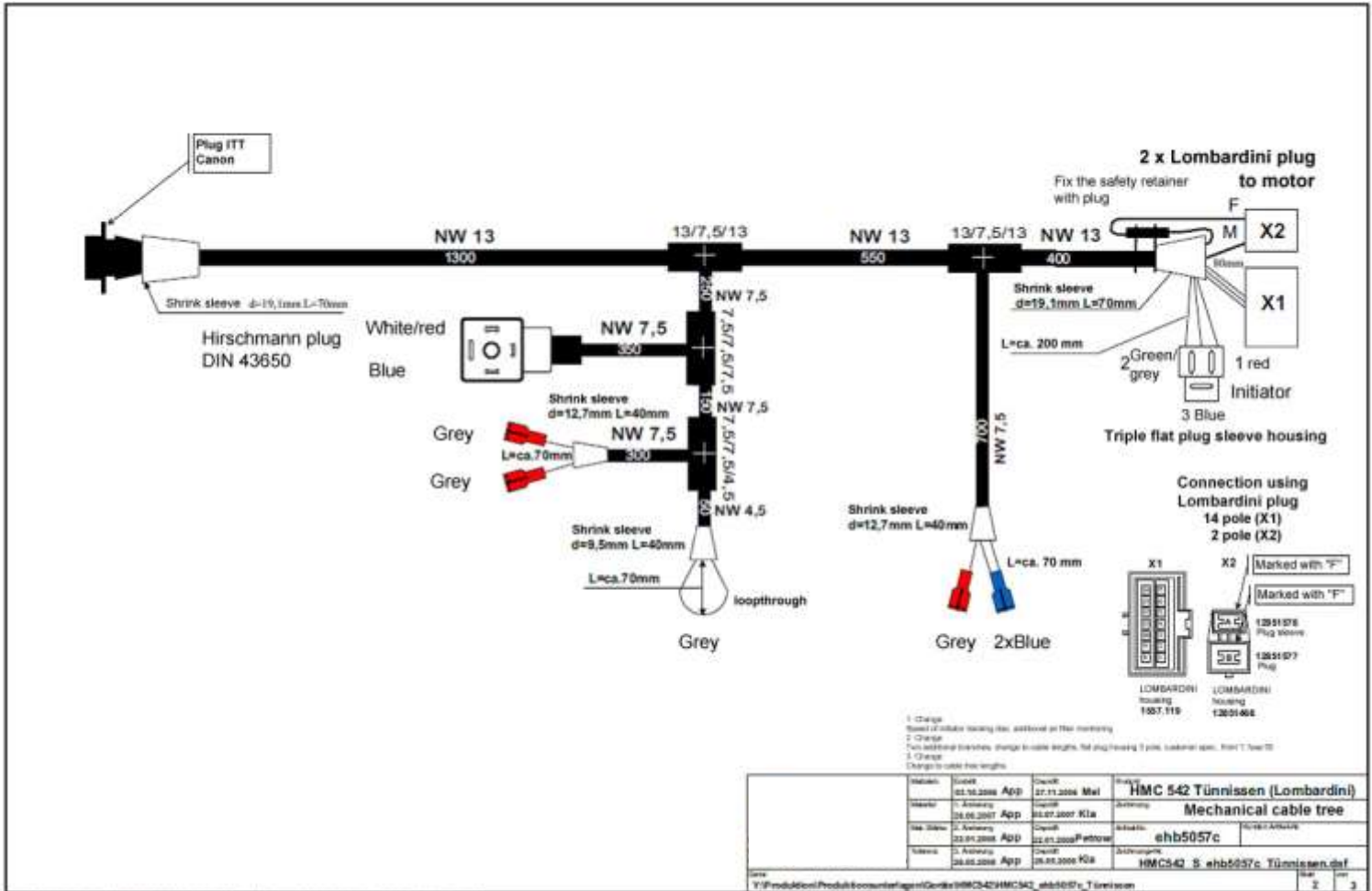

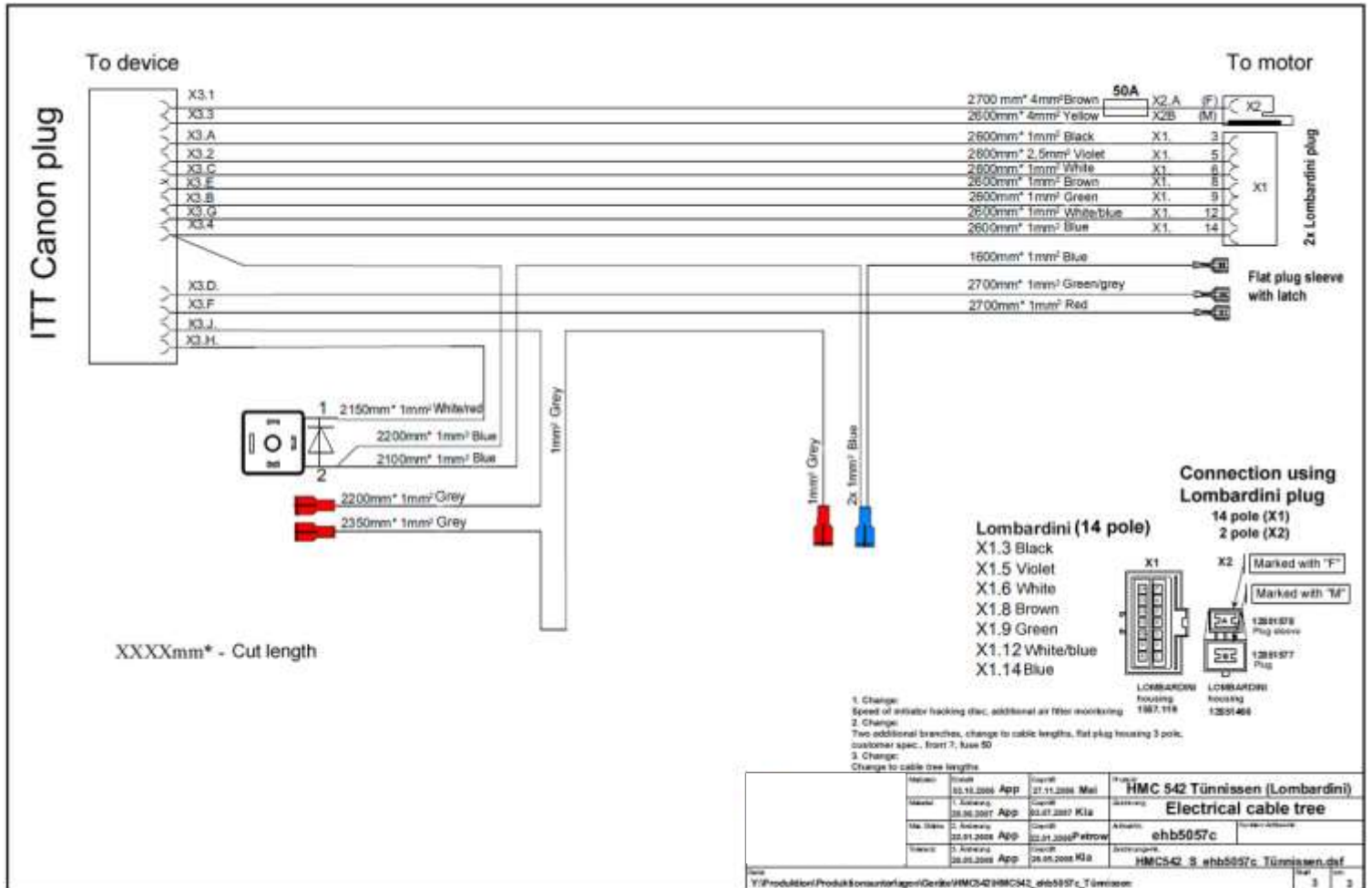



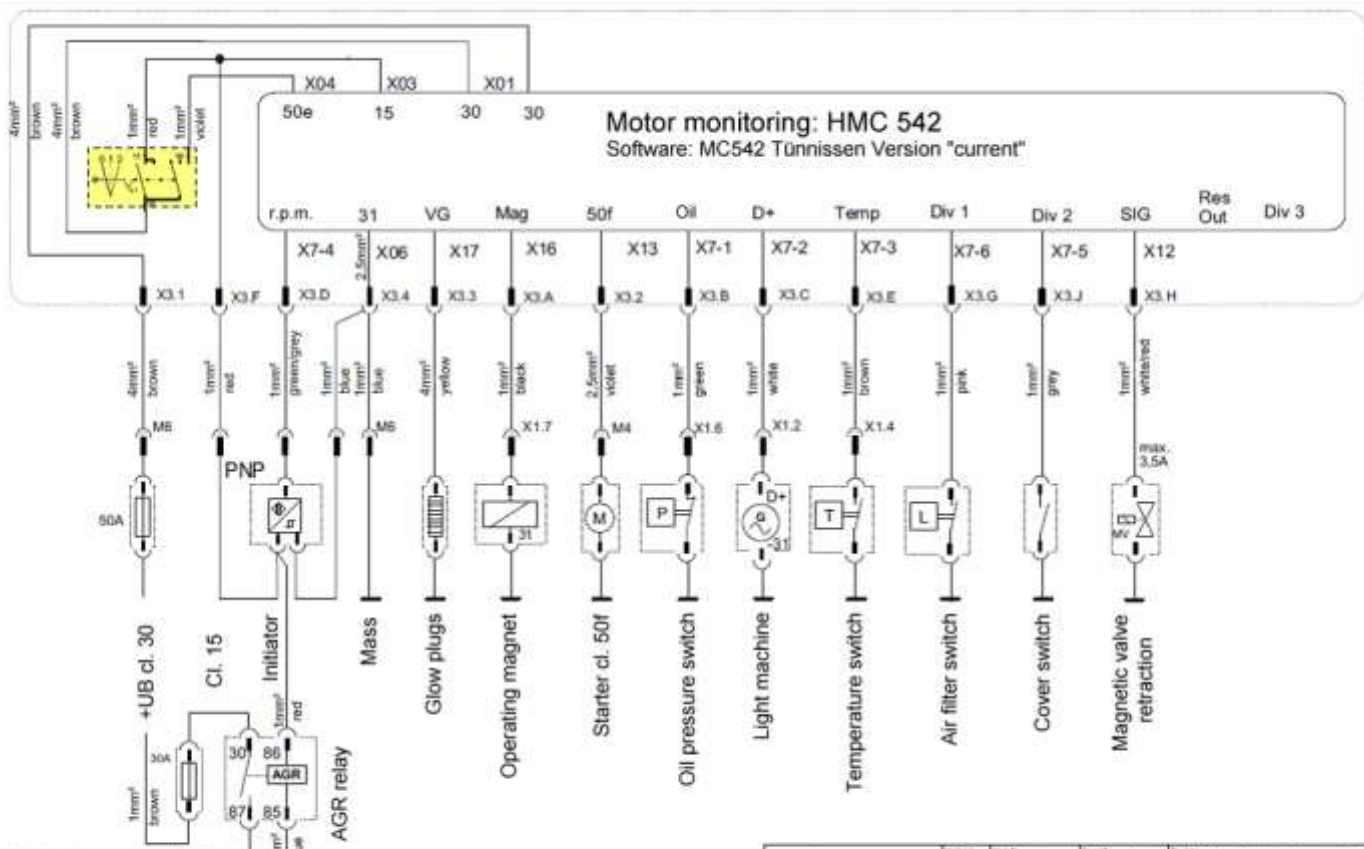

Motor monitoring: HMC 542  
Software: MC542 Tünnissen Version "current"

Central motor plug  
Voltage supply AGR

Caution: All inductors (e.g. lifting magnet) must be provided with an interference suppressed diode (e.g. 1N4007)!

1. Change: Change to brackets according to customer specification.  
2. Change:  
3. Change:

Version	Created	21.04.09 App	27.04.09 Kja	Project	HMC 542 Tünnissen (Deutz 2011)
Modifik	1. Änderung	01.09.2009 Ste	04.09.09 App	Customer	Switch plan
Mod. Status	2. Änderung			Artikelnr.	ehb5193
Version	3. Änderung			Hersteller	HMC542_S_ehb5193_Tünnissen.dpf
V:\Produktion\Produktion\anfertigen\Caribot\HMC542\HMC542_ehb5193_Tünnissen					
					1

Please clamp off the battery before work on the electrical system.

350M / 450M / 550M

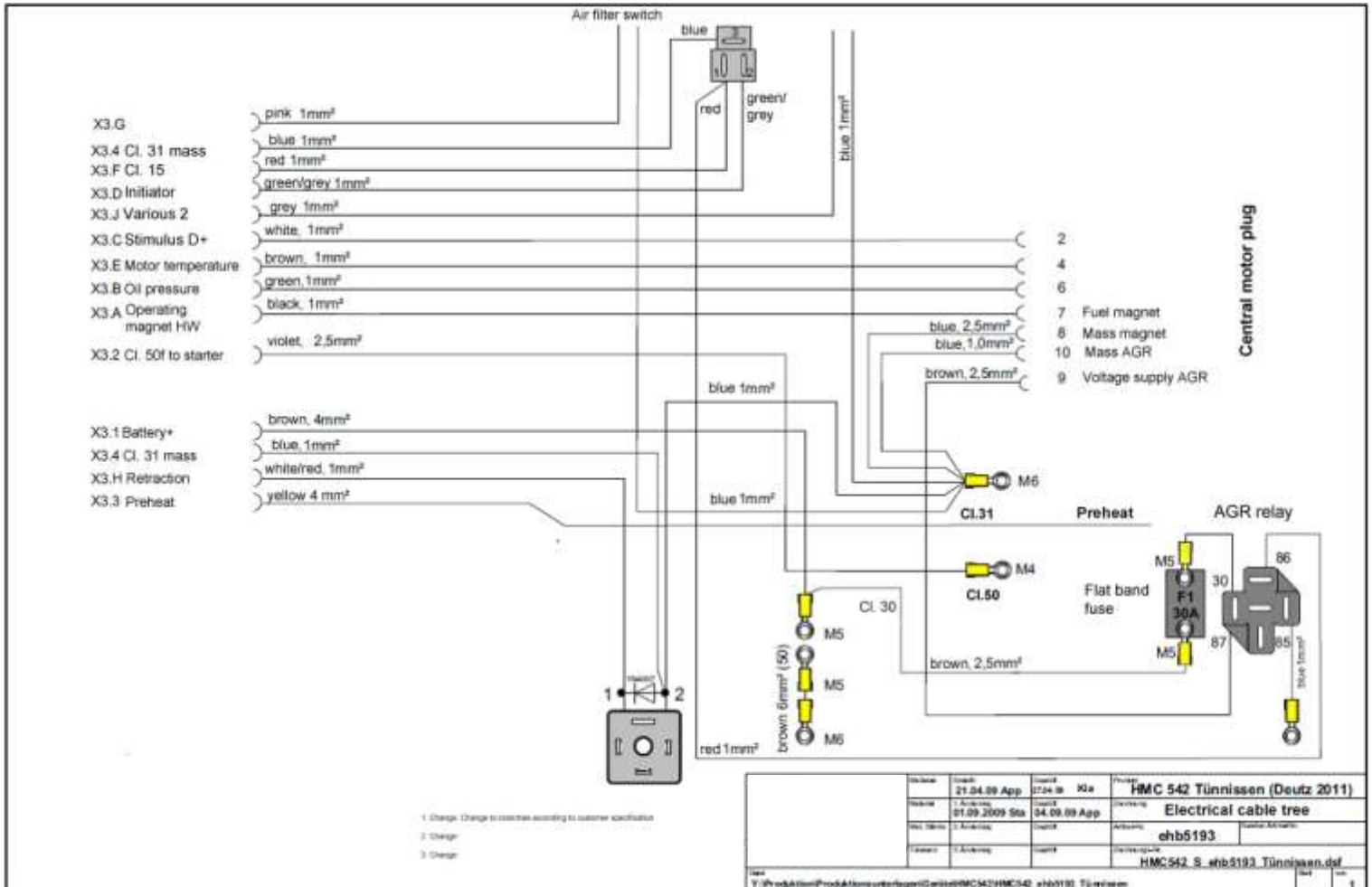

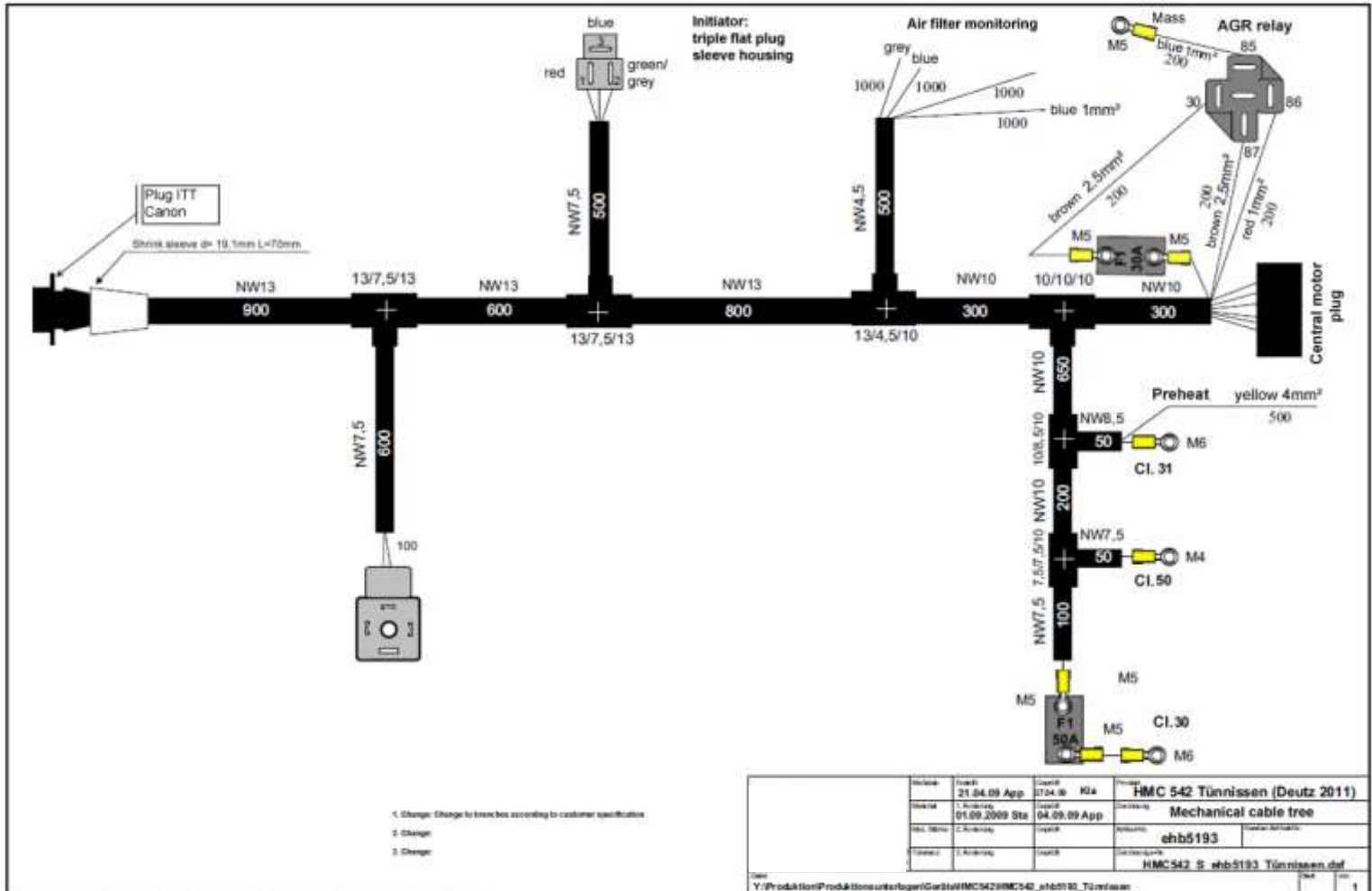

## General EPS (electric switching)

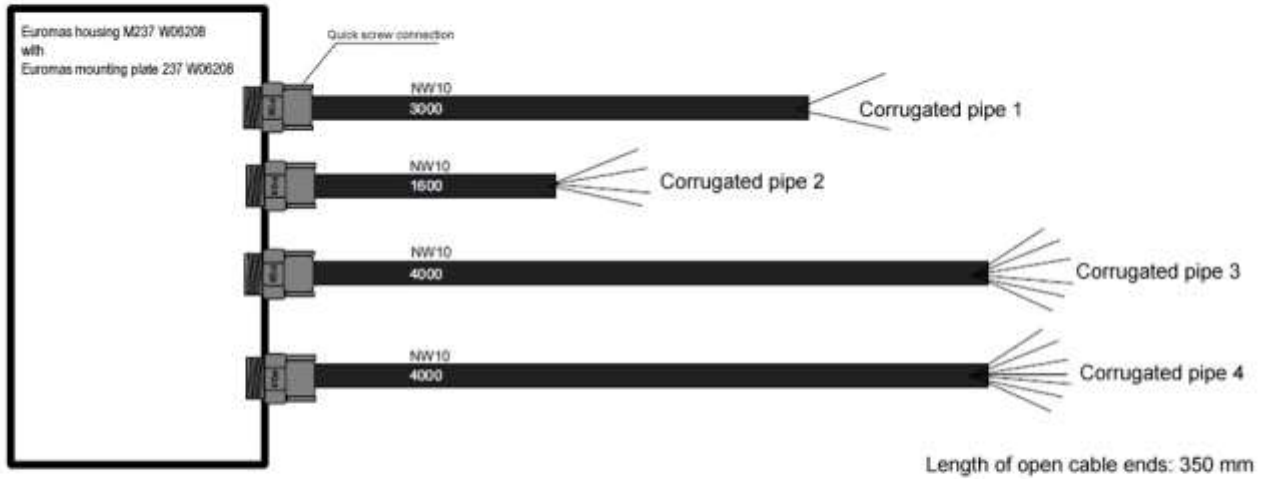

		1. Änderung		2. Änderung		3. Änderung		
Version	0001	2022.10.11	Sta	0001	2022.10.11	App	Relaisbox Tünnissen	
Skizze	1. Änderung			0001			Mechanical front plate	
Mod. Skizze	2. Änderung			0001			ehb5354	
Skizze	3. Änderung			0001			Relaisbox_ehb5354_Tünnissen.def	
Datei							1	2
1:\Produktion\Produktionsunterlagen\Geräte\Relaisbox\Relais box_ehb5354_Tünnissen								

# General EPS (electrical switching)

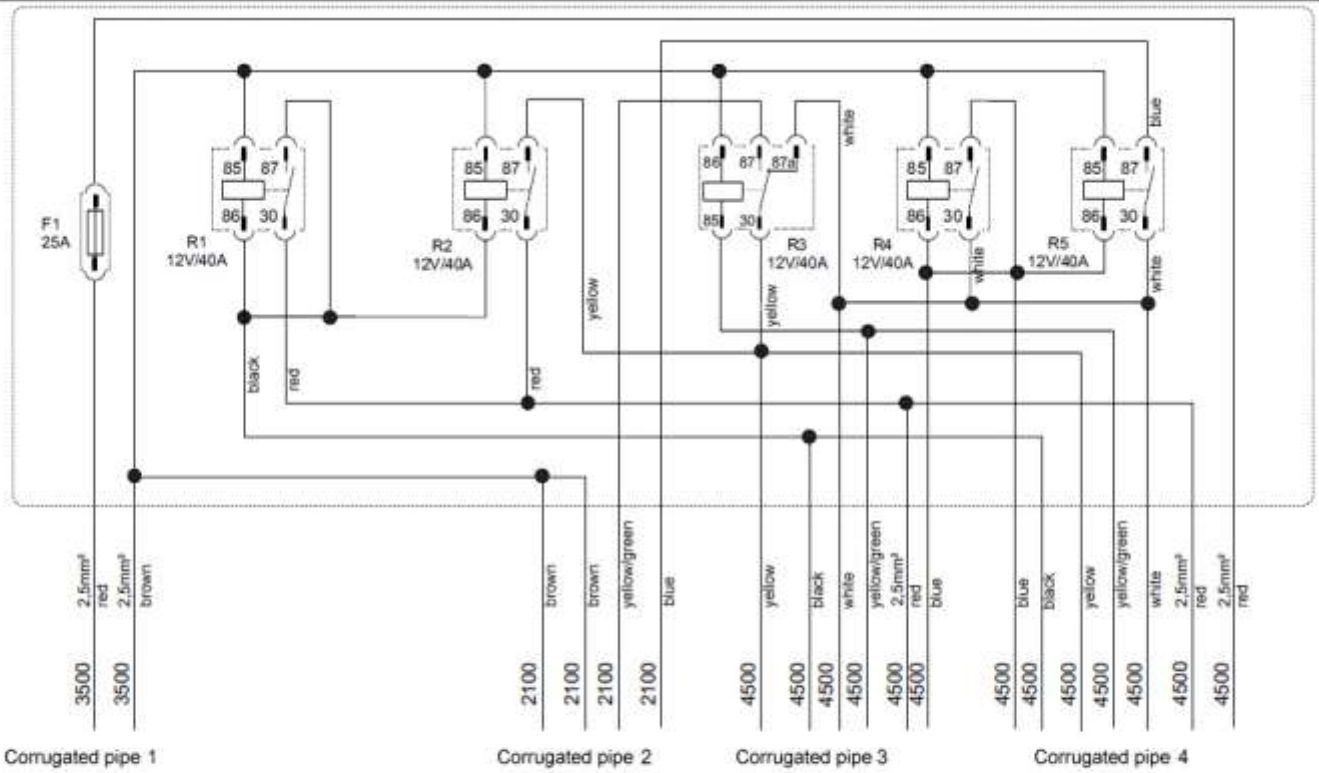

Not all marked cables 1mm<sup>2</sup>

- 1. Adresse
- 2. Adresse
- 3. Adresse

Material	Code	Stk	Quant	App	Caja de relés Tünnissen	
Material	1. Adresse		Quant		Adresse	
Ma. 3304	2. Adresse		Quant		ehb5354	1. Adresse
Material	3. Adresse		Quant		Relaisbox_ehb5354_Tünnissen.dsf	
<small>                 1. Adresse                  2. Adresse                  3. Adresse             </small>						

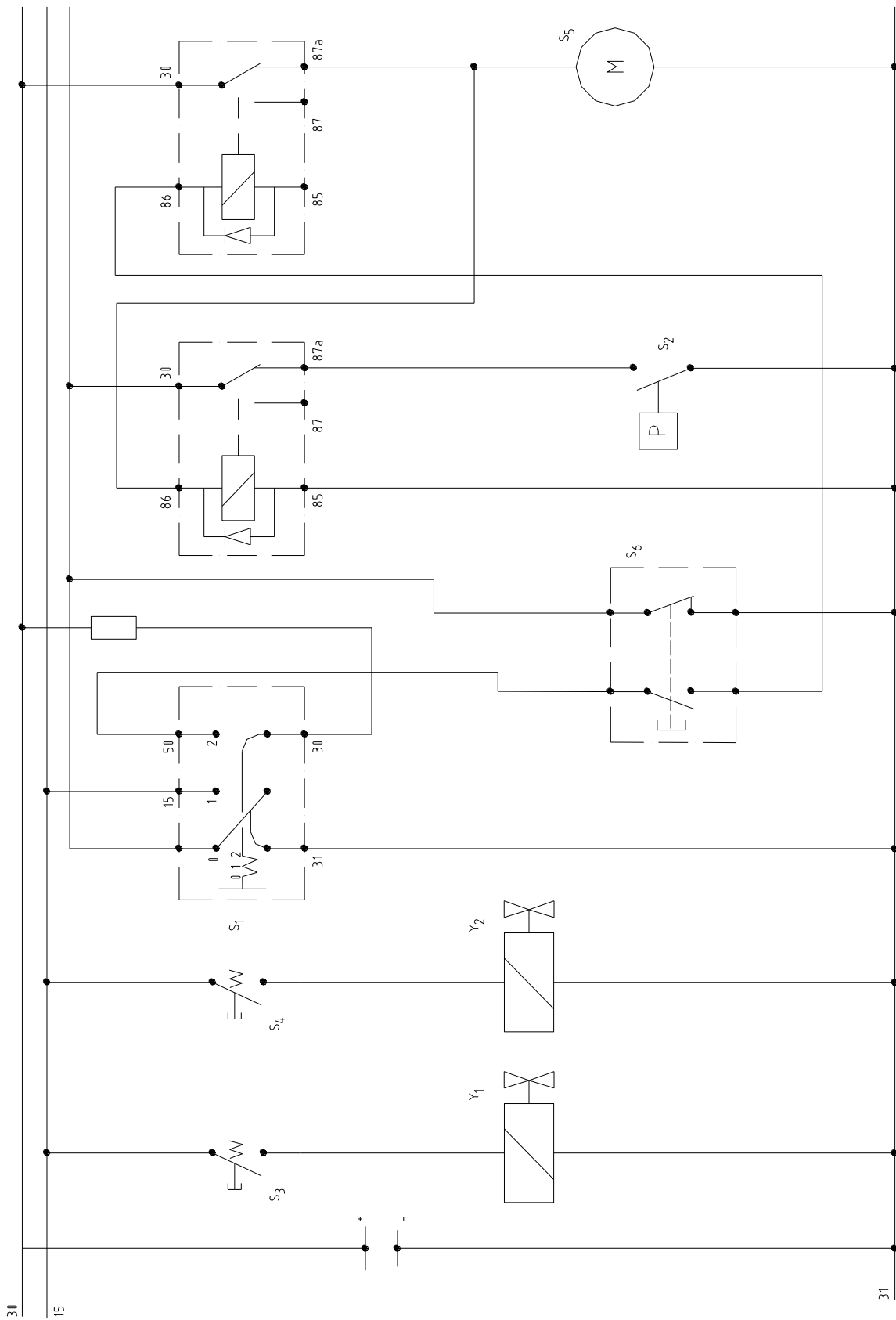

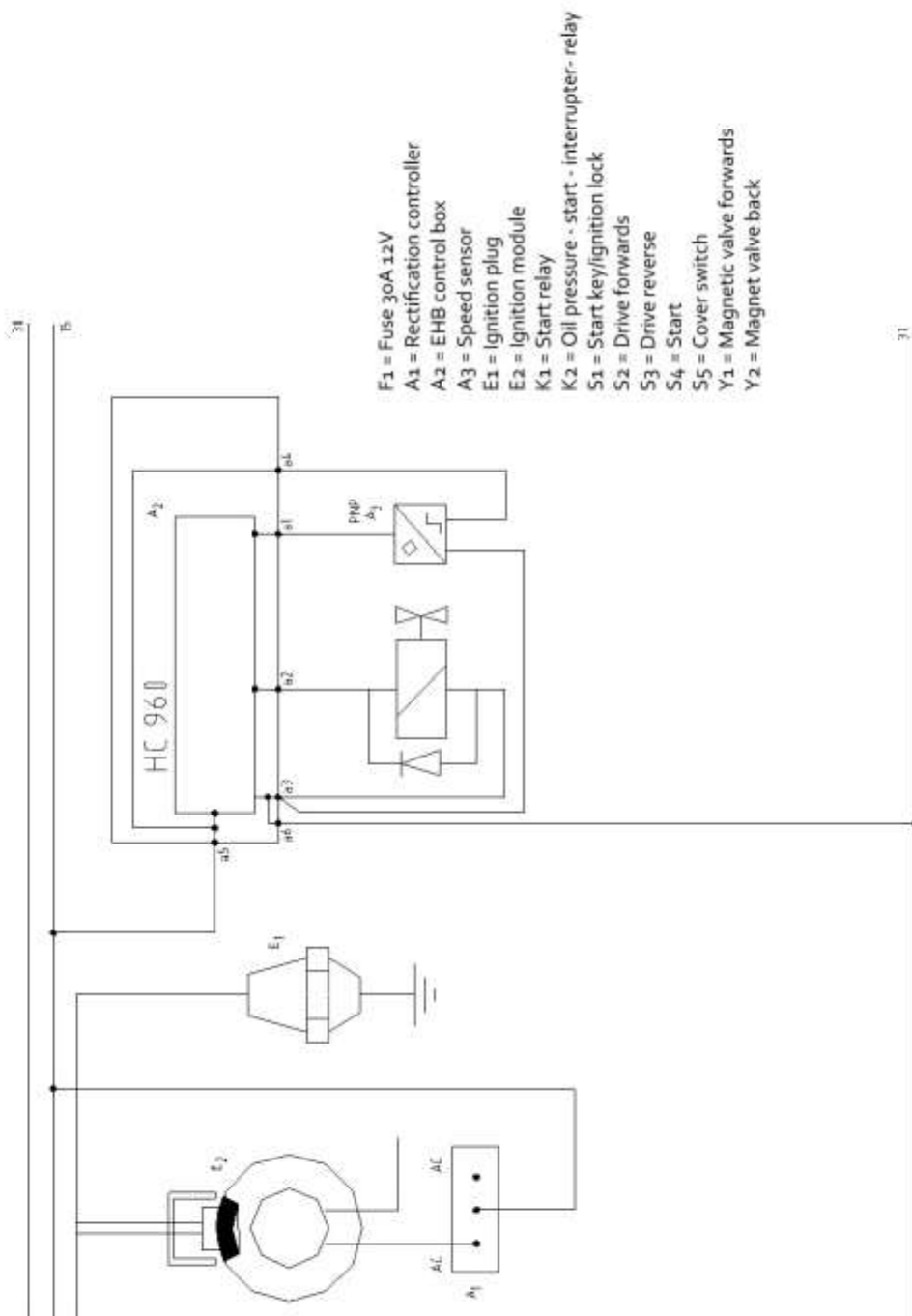

# Inspections

Operating hours: ..... Date: ..... Signature: ..... .....	Operating hours: ..... Date: ..... Signature: ..... .....
Operating hours: ..... Date: ..... Signature: ..... .....	Operating hours: ..... Date: ..... Signature: ..... .....
Operating hours: ..... Date: ..... Signature: ..... .....	Operating hours: ..... Date: ..... Signature: ..... .....
Operating hours: ..... Date: ..... Signature: ..... .....	Operating hours: ..... Date: ..... Signature: ..... .....
Operating hours: ..... Date: ..... Signature: ..... .....	Operating hours: ..... Date: ..... Signature: ..... .....
Operating hours: ..... Date: ..... Signature: ..... .....	Operating hours: ..... Date: ..... Signature: ..... .....
Operating hours: ..... Date: ..... Signature: ..... .....	Operating hours: ..... Date: ..... Signature: ..... .....
Operating hours: ..... Date: ..... Signature: ..... .....	Operating hours: ..... Date: ..... Signature: ..... .....
Operating hours: ..... Date: ..... Signature: ..... .....	Operating hours: ..... Date: ..... Signature: ..... .....



# Inspections

Operating hours: ..... Date: ..... Signature: ..... .....	Operating hours: ..... Date: ..... Signature: ..... .....
Operating hours: ..... Date: ..... Signature: ..... .....	Operating hours: ..... Date: ..... Signature: ..... .....
Operating hours: ..... Date: ..... Signature: ..... .....	Operating hours: ..... Date: ..... Signature: ..... .....
Operating hours: ..... Date: ..... Signature: ..... .....	Operating hours: ..... Date: ..... Signature: ..... .....
Operating hours: ..... Date: ..... Signature: ..... .....	Operating hours: ..... Date: ..... Signature: ..... .....
Operating hours: ..... Date: ..... Signature: ..... .....	Operating hours: ..... Date: ..... Signature: ..... .....
Operating hours: ..... Date: ..... Signature: ..... .....	Operating hours: ..... Date: ..... Signature: ..... .....
Operating hours: ..... Date: ..... Signature: ..... .....	Operating hours: ..... Date: ..... Signature: ..... .....
Operating hours: ..... Date: ..... Signature: ..... .....	Operating hours: ..... Date: ..... Signature: ..... .....

# Inspections

Operating hours: ..... Date: ..... Signature: ..... .....	Operating hours: ..... Date: ..... Signature: ..... .....
Operating hours: ..... Date: ..... Signature: ..... .....	Operating hours: ..... Date: ..... Signature: ..... .....
Operating hours: ..... Date: ..... Signature: ..... .....	Operating hours: ..... Date: ..... Signature: ..... .....
Operating hours: ..... Date: ..... Signature: ..... .....	Operating hours: ..... Date: ..... Signature: ..... .....
Operating hours: ..... Date: ..... Signature: ..... .....	Operating hours: ..... Date: ..... Signature: ..... .....
Operating hours: ..... Date: ..... Signature: ..... .....	Operating hours: ..... Date: ..... Signature: ..... .....
Operating hours: ..... Date: ..... Signature: ..... .....	Operating hours: ..... Date: ..... Signature: ..... .....
Operating hours: ..... Date: ..... Signature: ..... .....	Operating hours: ..... Date: ..... Signature: ..... .....
Operating hours: ..... Date: ..... Signature: ..... .....	Operating hours: ..... Date: ..... Signature: ..... .....



### **Saelen**

3 rue Jules Verne  
L'Orée du Golf - BP 17  
59790 Ronchin  
Tél : + 33 (0)3 20 43 87 87  
Fax : +33 (0)3 20 34 12 73  
contact@saelen.fr www.salen.Fr

---

### **Pièces détachées**

Tél : + 33 (0)3 20 43 24 89  
Fax : +33 (0)3 20 34 12 73

### **TS Industrie**

TS Industrie GmbH  
Weserstr. 2  
D - 47506 Neukirchen - Vluyn (Germany)  
Tel.: +49 2845 / 9292-0  
Fax: +49 2845 / 9292-28  
kontakt@ts-industrie.de

---