



GS/PUMA35D

OPERATING MANUAL

saelen.fr ts-industrie.eu

SAELEN® TS INDUSTRIE®

TABLE OF CONTENT	
Declaration of conformity	4
Attention	5
Guaranties	6
Brevet d'invention	7
Preface	8
Location of the serial number	9
Safety instructions	10 - 12
Pictographs	13 - 15
Safe transport	16
General description and functions	17 - 19
Operation	20
Coupling the machine to a vehicle	21
Checks prior to initial start-up of the machine	21
Operation	22
Material infeed and operation	23
Shut-down	24
Biodegradable lubricants for reducing environmental pollution	25
Lubricant, filling quantity	26
Engine maintenance intervals	27
Lubricating points	28 - 29
Oil levels	30
Adjusting the tension of the conveyor belt	31
Check condition of conveyor belt and sliding plate	32
Vent openings under the rotor	32
Knife and insert replacement	33 - 34
Check counter-knife	35
Tensioning the V-belt of the rotor drive	36
Tensioning the drive belt chain for the infeed roller	37
Brake adjustment	38
Control element of the engine	39
PILOT SYSTEM	40 - 49
Tanks	50
Hood and expulsion channel safeguard	51
Emergency stop switches	52
Proximity sensor and fuse	53
Expulsion channel	54
Troubleshooting	55 - 56
Specifications	57
Hydraulic connections	58
Hydraulic circuit diagram	59
Electric circuit diagram engine	60 - 61
Electric circuit diagram machine	62 - 63

DECLARATION OF CONFORMITY

LA SOCIETE **TS industrie**

Weserstrasse 2
47506 NEUKIRCHEN-VLUYN

Tél : +49(0)2845 9292-0 - Fax : +49(0)2845 9292-28

HEREBY DECLARE THAT THE MACHINE:

Trade Name: **TS Industrie**

Type : **GS/PUMA35D**

Engine performance: **26,2 kW**

Technical documentation held by Mathieu Willerval.

is in conformity with the following European Directives:

- **2006/42/EC** Directive „Machinery“
- **2014/30/EU** Directive „Electromagnetic compatibility“
- **2016/1628** Directive „Emissions“
- **2000/14/EC** Directive „Noise emissions“

Conformity evaluation procedure concerning directive 2000/14/CE Annex V.

<i>Power at 3000 rpm</i>	<i>Measured sound pressure level</i>	<i>Guaranteed sound pressure level (EVA)</i>
26,2 Kw	124 dBA	126 dBA

RONCHIN, September 30, 2014



Mathieu Willerval (Production Manager TS Industrie)



Attention!

Before our machines are delivered they pass a tight quality control in the works.

Given that we no longer have a bearing on the machine after it leaves the works, the dealer has to perform another check before the delivery to the end customer.

The following is to be checked:

- Exterior damages produced by transport etc.
- Tight seat of all screw and hose connections
- Filling level of oil, water and fuel
- Complete functional control of all parts

This control is to be confirmed with stamp and signature on the **Machine Delivery Document**. If the fully completed and signed delivery document is not returned there is no right for warranty!

Furthermore, it is required to check all screw connections for tight seat and the laid hoses for marks of abrasion!

Agree a date for this directly with your customer.

Regular inspections according to the operating manual are to be met!

Controlled quality – an important step towards customer satisfaction!
Play your part!

Guarantees

Processing of warranty claims

Warranty claims according to the General Business Terms of the manufacturer are valid for the period of 1 year starting with the day of delivery.

Determinative for the moment of the transfer of risk is the date written in the **Machine Delivery Document**. As a matter of principle, warranty claims are to be announced to the supplying franchised dealer. For the preservation of evidence, all parts of the delivered machine covered by this have always to be stored unchanged until the final processing of the warranty claim brought to notice.

Technical modification at machines and/or parts thereof will result in loss of any and all right of warranty claims. The same is applicable in case of inappropriate treatment or use of lubricants and spare parts or accessories not approved by the manufacturer. Transport damages and damages caused by usual wear after commissioning of the machine do not create any warranty claims.

The delivered machine has to be subjected to the obligatory check and inspection intervals specified in the enclosed maintenance schedule. If the obligatory visual check and inspections schedule is not complied with, any and all warranty claims become void. Another requirement for a valid warranty claim is the presentation of a complete proof about the executed obligatory visual checks and inspections.

All warranty and maintenance works are only allowed to be carried out by a specialist dealer authorised by **TS Industrie**.

It is pointed out that warranty works exceeding an amount of 150.00 € is unconditionally to be agreed with **TS Industrie** and authorised by **TS Industrie**. In this case, the manufacturer reserves the right that he carries out the repair.

Prerequisite for the assertion of a warranty claim is the return of the fully completed and signed Machine Delivery Document.



Modifications on the equipment and programming of the electronic system are prohibited because these might have a negative effect on the operational safety and life time of the machine.

**DO NOT FORGET TO REGISTER THE WARRANTY,
OTHERWISE IT WILL BECOME VOID**

**www.ts-industrie.eu
Section: Services / Warranty**



BREVET D'INVENTION

Code de la propriété intellectuelle-Livres VI

DECISION DE DELIVRANCE

Le Directeur général de l'Institut national de la propriété industrielle décide que le brevet d'invention n° 60 60730 dont le texte est ci-annexé est délivré à :
SAELEN S.N.S. Société anonyme - FR

La délivrance produit ses effets pour une période de vingt ans à compter de la date de dépôt de la demande, sous réserve du paiement des redevances annuelles.

PATENT FOR INVENTION

Intellectual property law-Books VI

GRANTING DECISION

The General Manager of the National Institute of industrial property has decided that invention patent # ##-##### the text of which is appended shall be delivered to:
SAELEN S.N.S. Company - FR

The delivery produces its effects for a period of twenty years starting on the date of deposit of the application, under reserve of payment of the annual royalties.

Mention of the delivery is made in the Official Bulletin of industrial property ##### of ##:##:## (publication # # ## # ##).

Le Directeur général de l'Institut
national de la propriété industrielle

D. HANGARD

INSTITUT
NATIONAL DE
LA PROPRIÉTÉ
INDUSTRIELLE

SIEGE
26 bis, rue de Saint Petersburg
75000 PARIS cedex 08
Téléphone : 01 53 04 53 04
Télécopie : 01 42 93 59 30

ETABLISSEMENT PUBLIC NATIONAL ORGÉ PAR LA LOI N° 51-441 DU 19 AVRIL 1951

SAELEN TS INDUSTRIE

Preface

We thank you very much for deciding to purchase an universal chipper from **TS Industrie**. Your universal chipper was manufactured with utmost care and high quality standards. In order to meet these requirements also for the mostly professional applications, we kindly ask you to diligently read this operating manual and to comply especially with the warning and maintenance information. Only if complying with all maintenance works within the specified maintenance intervals we can concede the full manufacturer's warranty for your universal chipper from **TS Industrie**.

The operating manual includes several models such that in the introduction is explained how to orient yourself with the help of small pictographs.



Location of the serial number

For any spare parts order or a question regarding technical information have always the serial number of your PUMA 35D at hand.

Manufacturer's type plate



The serial number is located as shown in the image. It does always have **five- or six-digit number**.

Serial number

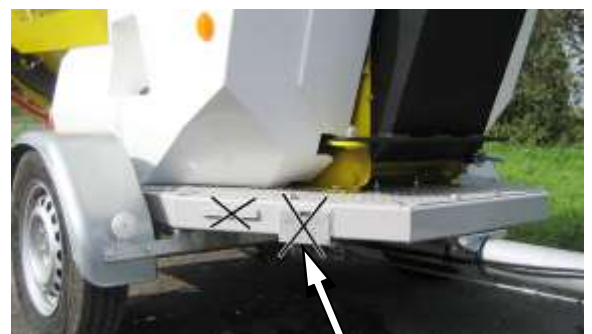

Do not state the number from the type plate of the trailer.

Safety instructions

- 1.** The machine is only allowed to be used according to the operating manual!
- 2.** In case of machines with engine also the operating instructions of the engine are to be observed.
- 3.** Folding the intake extension up (as far as present) is only allowed after standstill of the rotor.
- 4.** Maintenance, cleaning and setting works as well as the removal of protective devices are only allowed after the engine is shut down, the ignition switched off, the drive decoupled and the tools immobile. Remove the ignition key such that unintended start is impossible.
- 5.** Prior to operation it is required to remove foreign matters, e.g. ferrous parts, stones etc.
- 6.** After maintenance or repair it is to be checked if all protective devices are mounted.
- 7.** The wood chipper is not allowed to be operated in closed spaces because of the risk of intoxication.
- 8.** The rotor must not be uncovered before it has reached standstill. That is to say, the propulsion engine (tractor) is parked and the ignition is in 0-position.
- 9.** The machine operator is responsible that no third persons are staying in the working and danger area.
- 10.** For repairs it is to be observed to use approved original spare parts only.
- 11.** Only persons of over 18 years are allowed to operate the wood chipper.
- 12.** Safety shoes and tight fitting clothes, work gloves with tight gauntlets as well as ear protection and goggles are to be used.

- 
- 13.** For transporting the wood chipper it must be moved into transport position.
- A) Fold the hopper (as far as present) up and check if the locking device is engaged.
 - B) Move the wood chipper into transport position and check if the safety pin has engaged.
 - C) Turn the ejection channel such that it does not jut laterally out over the machine.
 - D) If necessary lift all parking sustainers.

14. When driving on public roads the lighting must correspond to the Highway Code.

15. For work, the wood chipper must be parked stable.

16.

a) Single-axle machines with engine are attached to tractor vehicles, and the parking brake is applied as far as present.

In case of machines without brakes it is required to push the supplied chocks under the wheels.

b) For operation without tractor vehicle it is required to lower the parking sustainers (front and rear).

17. For safety reasons a minimum distance of 10 metres should be kept from the machine.
The expulsion must always be directed away from the operating personnel.

18. Only after the engine is shut off and the rotor is standing still, it is allowed to reach with the hands into the infeed mouth.

19. The admissible hydraulic operating pressure set ex works is not allowed to be changed.

20. Only trunks up to a diameter of 16 cm are allowed to be processed.

21. The hydraulic system is to be competently checked every year. The hydraulic hoses are to be replaced after 5 years.

22. During feed of the wood chipper do not reach into the feed hopper. Congestions are to be removed in a safe manner (shut the engine down, use an aid). For pushing in short pieces or shrubby material do only use solid wooden rods or other aids made of wood. Our wood chippers are designed only for manual feed. Do not use mechanical resources (gripper) for feeding the machine.

Do not move in the area of the expulsion.



23. Carry out an functional check every day before starting the machine, especially of the safety equipment (**trailer coupling**, gear linkage, shifting block, cut-off switch on the hoods in case of the M version etc.). Chipping knives and counter-knives are also to be checked for proper functioning and tight seat.

24. Prior to starting the machine the operator must be trained in detail.

25. The rotor must not be uncovered before standstill and the engine is switched off.

26. Danger because of flying off pieces. It is to be observed that also in the operating range pieces such as wood chips might fly out of the hopper area. Body protection is always to be used. Operation is to be carried out lateral of the hopper.

27. Note for all machines with engine:

The inclination of the engine during operation (driving) must amount to max. 25°. In case of reduced oil level the lubrication of the engine is not ensured even at 25°!

28. Caution when parking the machine on a slope. The machine operator has to ensure that the machine is safely stationed for the time of the work.

29. **After connecting the machine to the tractor vehicle, remove and store the support wheel.**

30. The machine must only be fed with wood. Ensure that no stones or metal objects enter the machine.

31. The machine must not be used for transporting material or persons.

32. The machine must not be used for pushing or towing.

33. Battery acid is a caustic fluid. Therefore any contact with eyes, skin and clothes must be avoided. In case of contact rinse all affected areas with water and go see a doctor, if required.

34. Always disconnect the battery before any work on the electric installation.

35. Only **trained personnel** is authorised to carry out these works. The execution of all installation and removal works as well as special maintenance works is reserved for an authorised specialist dealer.

36. Pay attention that you are not drawn into the infeed roller with the clothes.

37. Regularly clean the lateral skirt such that it remains transparent.

Pictographs

Wear eye and ear protection!



Use protective gloves with specially tight gauntlets!



Wear safety shoes!



Do only touch machine parts after they are at a complete standstill!



Keep sufficient distance to rotating machine parts!



Pictographs

While the drive is running never open and remove protective devices!



Read the operating manual before start-up!



Do not stay in the area of the expulsion if the machine is running! Hazard area!

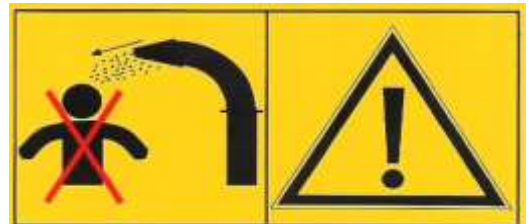

Shut down the engine and remove the key prior to any maintenance and repair work!



Caution! Entanglement.

Never reach into the infeed hopper while the engine is running.



Fill the fuel tank with **diesel**.



The machine is operated with hydraulic oil HV46.

HYDRAULIC

Lubrication points

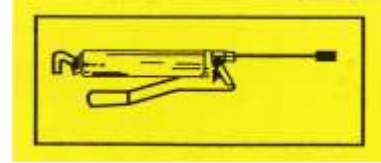

The sound level of the working machine is not the value of the standard level on the sticker.



Minimum RPM motor

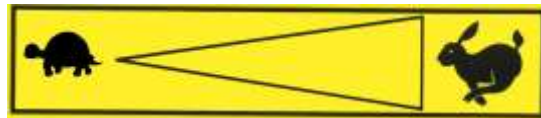

Maximum RPM motor

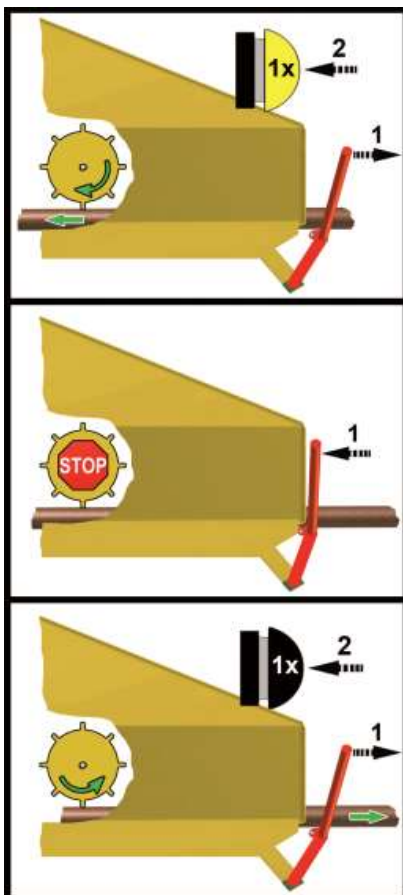

Moving direction commands for the conveyor belt

Material chipping (forward **max. speed**)

Stopping rotation of the infeed rollers

Loosening material (backwards)

SAELEN TS INDUSTRIE®

Safe transport

- 1) Observe the valid Highway Code.
- 2) Ensure that the machine is always fitted with signal lights, which are clean and visible for other road users.
- 3) Reduce speed when driving on rural roads and unlevel routes.
- 4) Remove all remaining material from the hopper.
- 5) Turn the expulsion chimney completely to the front and fold the expulsion hatch completely down.

Coupling wear indication:

Check the wear indication each time the machine is hooked up to the tractor vehicle. Acquire the habit to replace the coupling dog and / or coupling ball of the vehicle as soon as the wear indication hits the negative area, such that you cannot loose the chipper when driving on rough roads or driving against a kerb when reversing.

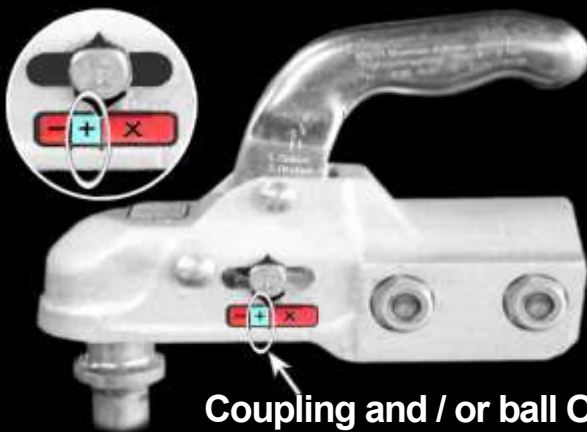

Coupling and / or ball OK

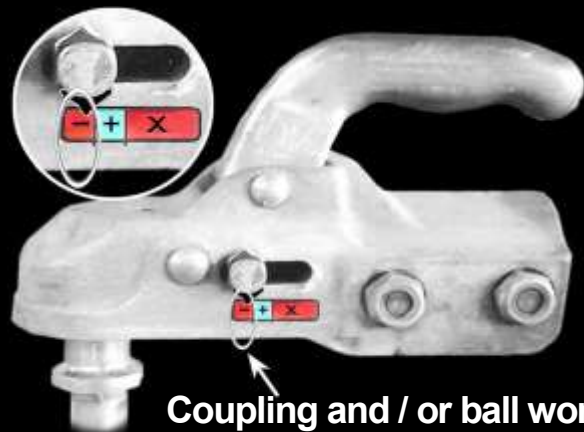

Coupling and / or ball worn

Coupling to a vehicle:

The chipper should always be coupled in horizontal position such that the machine is prevented from tilting backwards AND check every day that the drawbar adjusting devices are secured to prevent jerky movements, which damage coupling and towing device and reduce the life span.

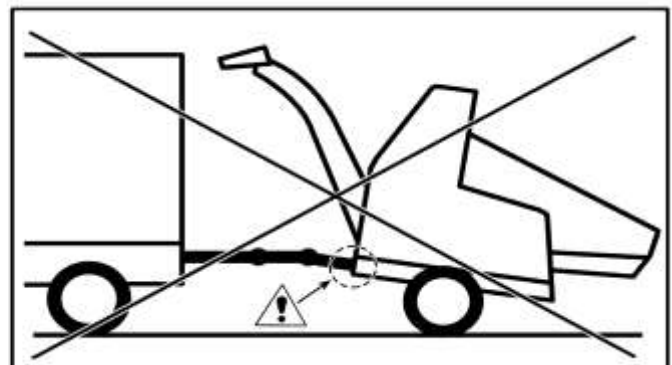
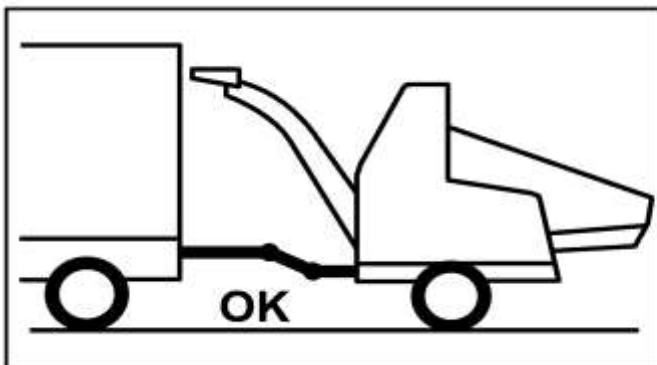

General description and functions

DESCRIPTION OF THE MACHINE

The chipper **PUMA 35D TS Industrie** is designed for chipping branches up to a **diameter of 6,30 inches**.

The machine consists of the following main components:

- (A) : Frame
- (B) : Chipping unit
- (C) : Engine and drives
- (D) : Expulsion chimney
- (E) : Noise insulation hoods

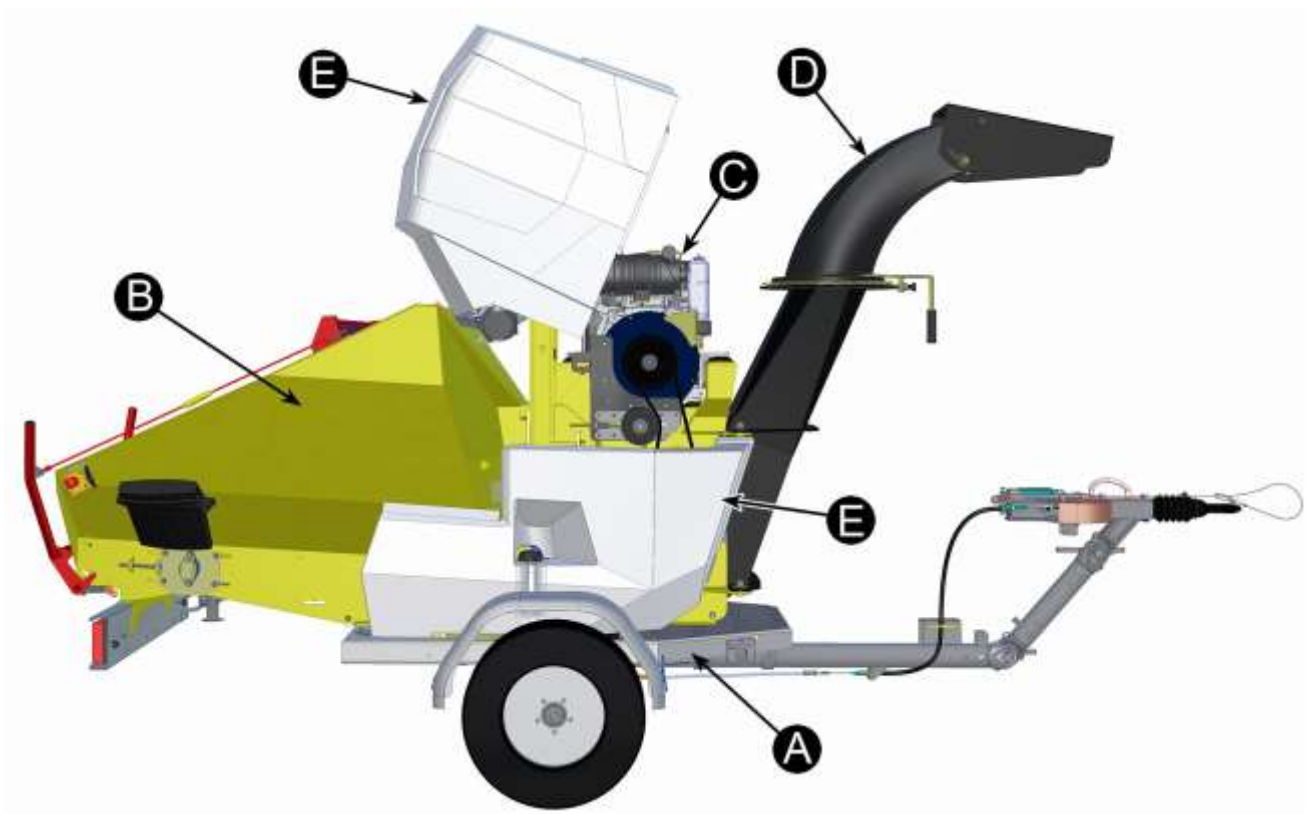

General description and functions

A. Frame

The frame is used for allocating the different components of the chipper **PUMA** and allows an independent movement of the machine.

B. Chipping unit

The unit consists of one infeed hopper (1), one conveyor belt (2), one infeed roller (3) and one rotor.

Conveyor belt and infeed roller:

They transport the chipping material at constant speed in direction rotor. An anti-blocking system disconnects the infeed if the speed of the rotor falls below the minimum speed (chipping unit jammed) and automatically connects again after the speed of the rotor is sufficient for correct chipping work.

The infeed can turn into both directions (forward and backwards) when using the yellow and the black button (4) located on the left side of the infeed hopper.

The speed of rotation can be matched to the diameter of the material to be chipped using the regulating screw (4) on the left side of the rear hood.



Rotor:

The rotor is the main component of the machine and has the task to chip the material coming from the infeed roller. After the engine accelerates, the rotor connects and rotates at a constant speed.



SAELEN TS INDUSTRIE®

General description and functions

C. Engine and drives

The diesel engine is located above the chipping unit. It supplies the required energy for the drive of the rotor and the hydraulic oil pump (1).

The machine is driven by a 3-cylinder diesel engine with an output of 35 HP at 3000 rpm. Further information regarding the engine can be taken from the manual of the manufacturer.

The rotor is driven via the output shaft, the centrifugal clutch with belt pulley (2) and 3 V-belts. The hydraulic pump is connected to the diesel engine and drives the hydraulic motors of the infeed rollers.

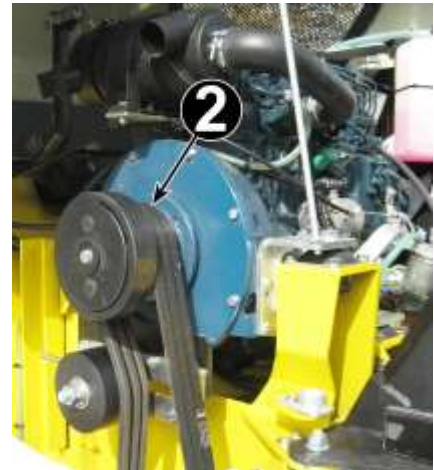

D. Expulsion channel

This expulsion channel expulses the chipped material. The upper part can be swivelled by 180° in horizontale position. The expulsion hatch can be adjusted in vertical position.



Caution:

When connecting the wood chipper residual chips can be expulsed.

Two electric switches disconnects the engine and prevents a re-start if the expulsion chimney is open towards the rotor.

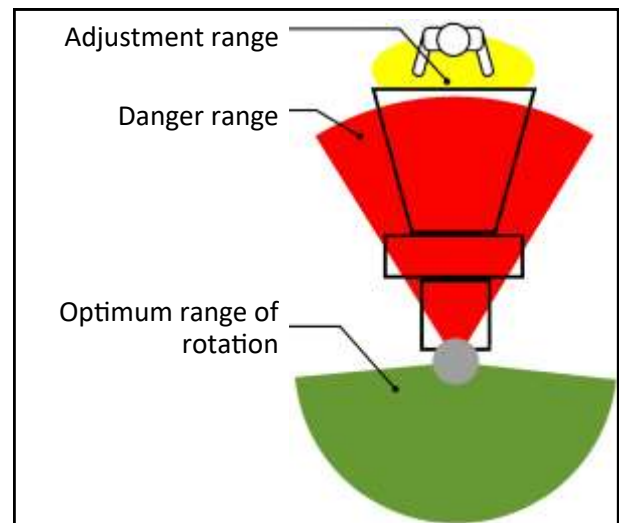

E. Hood

Different hoods protect against rotating parts making work safe.

Two electric switch disconnects the engine and prevents a restart when opening the hoods.

MATERIAL INFEED

The **PUMA** is fitted with an electrically controlled hydraulic distributor, which is activated with two buttons at the rear of the infeed hopper for running forwards and backwards, and with a red control rod for disconnection of the infeed roller and the conveyor belt.

Note: The engine has to run at max. speed for making the conveyor belt and the infeed roller turn.

FORWARDS MODE:

1. Move the red control rod back such that the infeed roller moves to forward motion.
2. Push the **yellow** button to make the roller move forwards.

STOP THE INFEED:

1. Push the red control rod to make the in-feed stop.

BACKWARDS MODE:

1. Move the red control rod back
2. Push the **black** button.

NOTE: The infeed can be switched directly from forwards to backwards and vice versa without operating the control rod.

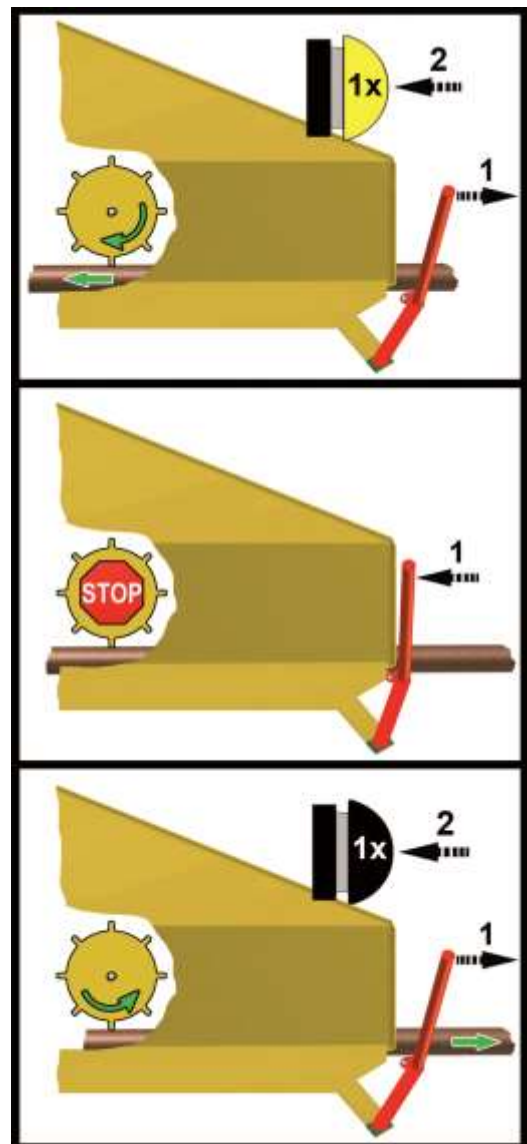



COUPLING THE MACHINE TO A VEHICLE

When hooking the wood chipper to a vehicle the procedure is as follows.

With the support wheel adjust the height of the drawbar such that the trailer coupling is standing above the vehicle. Now reel the support wheel in and the open ball head coupling has to engage on the ball of the trailer coupling.

Ensure that the trailer coupling safely engages!

The wear indication on the coupling must be in the green area (see page 16).

Then connect the arrestor cable with the vehicle and plug in the connector for the lighting. **Reel the support wheel completely in.** check the lighting.

CHECKS PRIOR TO INITIAL START-UP OF THE MACHINE

Every operator has to read and understand the provisions, and has to observe all safety measures included in this chapter. A list with the checks for initial start-up is available to the operator. These checks have to be carried out for safety reasons to ensure the safe and efficient operation of the chipper.

The following points are to be checked before using the machine:

1. The machine is sufficiently lubricated as indicated in the operating manual?
2. Check the following filling levels:
 - Engine oil
 - Coolant
 - Fuel
3. Check the hydraulic oil level.
4. Check that the air filter is clean.
5. Check that the engine radiator is clean.
6. Ensure that all hoods are closed and locked.
7. The machine must not be operated in confined spaces. Risk of intoxication because of the diesel engine exhaust gases and dust generation by the chipper.
8. The expulsion channel and the expulsion hatch are only allowed to be adjusted by an authorised operator.

Operate the machine only with Non-Road fuels or commercially available diesel fuel.

ATTENTION!

In case the machine shows difficulties in chipping the material and has to be switched off, **restart the engine only after having removed the cause and the material was removed from the rotor!!!**

START-UP

Each time before start-up of the machine ensure that it is standing stable on solid ground.

1. Check if the hatch of the expulsion channel is open.
2. Remove the safety pin, open the latch and lower the infeed table.
3. Turn the key to position **1** and connect the ignition.
4. Wait until the preheat lamp is off (approx. 10 sec.).
5. Turn the key to position **2** and start the engine. Let the engine run until it has reached operating temperature.
6. On the Pilot System choose the desired range **1, 2** or **3** (see page 42).
7. Accelerate the engine up to max. speed.

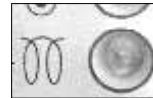

See page 44 if the engine immediately shuts down again and the message “Slip Error“ is displayed on the Pilot System.

DIE ANGEZEIGTEN WERTE SIND NUR AN-

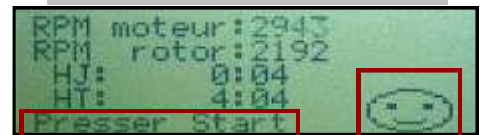

8. As soon as the engine has reached working speed, the message **Press Start** appears and a **Smiley**.
9. Press the **yellow** button on the infeed table to connect the infeed rollers.
10. Now work can be started.



Material infeed and operation

INSTRUCTIONS FOR CHIPPING

Watch out for solid foothold of the operating personnel!

Place chipping material on the hopper bottom and move it with the thicker end (trunk) towards the infeed rollers (chamfer the thick end of the trunk).

As soon as the material is captured by the rollers move to the side, because due to unevenness of the trunk there might be material kick-out.

The captured material now is automatically chipped and hurled into the direction (distance) into which the expulsion chimney was set to beforehand.

After the material infeed from time to time attention is also to be paid to the thrown out chippings, and maybe readjust the direction of ejection. The ejection distance of the material is controlled with the ejection hatch.

When chipping splints, barks and brush-wood splintering can be avoided by always feeding the material side-by-side and lengthwise positioned into the infeed channel.

If the feed stops (jamming because of too much material or forked branches), press the **black** button (rollers rotate backwards) and the chipping material is pushed back. Now reduce the material quantity, cut the forked branch, and restart the infeed.

The hopper can only be cleaned using appropriate wooden aids.

Caution:

 While the machine is running do not reach into the hopper! If required, push the kindling further using a wooden slat or wood slider! Never push the chipping material into the hopper using a metal rod or metal slider! It is also prohibited to stay in the danger area! In case of especially thick or hard wood, it makes sense to slow down the engine, reduce the speed until it has reached the rated speed.

If the area of the expulsion chimney is jammed, the hood must not be opened before standstill of the rotor and shut-down drive engine, and then the material can be removed with an appropriate tool.

Noise emission

The chipper produces a guaranteed sound power level according to Directive le 2000/14/EC :

Model	Sound power level EVA [dB]	Sound pressure level [dB(A)]
PUMA	126	124



SÆLEN TS INDUSTRIE®

SHUT-DOWN

1. Have the chipper run for some minutes empty for removing the residual material behind the infeed roller in the chipper to prevent that the rotor becomes jammed in the next application, and the message "SLIP ERROR" is indicated (see page 44).

2. For stopping the infeed roller move the control rod forward.



3. Set the engine to idle speed.

4. Turn the key on the control element to the left and shut the engine off.



BIODEGRADABLE LUBRICANTS FOR REDUCING ENVIRONMENTAL POLLUTION

Just by their function, the chippers from **TS Industrie** are used as a solution for the sustainable development for the production of compost, mulch and wood chips.

TS Industrie chippers are often used in woods, parks, landmarks, in the proximity of lakes and rivers, where leaks and hydraulic fluids signify a risk for the environment.

Therefore, the company **TS Industrie** contributes to the environmental protection by supplying their machines with **biodegradable high performance lubricants**.

Corresponds to the agricultural Directive 2006/11/EG.

Advantage of biodegradable lubricants:

- No risk for the environment
- Increase biodegradability
- Not toxic (based on rapeseed and sunflower oil)
- Regenerative
- Very high viscosity
- Excellent wear and anticorrosive properties
- Increased safety for the user
- Increased duration of the components
- Reduced volatility properties





SAFETY INSTRUCTIONS



1. Securely park the machine, remove the contact key and wait until the standstill of all mobile parts before starting the maintenance and repair works,
2. After termination of the maintenance works ensure that all protective devices are properly mounted and are operative.

All machines pass a test-drive before leaving the works. On delivery the hydraulic tank is filled up to the upper mark of the sight-glass with hydraulic oil. The filter has to be replaced after 150 operating hours. Thereafter, the replacement takes place according to the maintenance schedule. The first inspection is integral part of the warranty terms.

Only trained personnel is allowed to carry out maintenance and repair works.

The maintenance of the engine is to be carried out according to the enclosed operating instructions of the engine manufacturer.

On delivery, the bearings are lubricated and the transmissions are filled with oil. It is recommended to perform an inspection of the machine prior to initial start-up.

LUBRICANT: Filling quantity:

Engine: 6 l.

Fuel: 30 l.

Hydraulic oil: 15 l.



Recommended LUBRICANTS:

- 1) Lubricants for rotor knives:
Only a water resistant high-performance grease NLGI 2
"SAELEN BIOPLEX "
- 2) Lubricants for bearings, joints and different components:
Multi-purpose high-performance grease SAE (EP).
"SAELEN BIOPLEX "
- 3) Hydraulic oil:
AFNOR NFE 48603 Type HV ISO VG 46
"MINERVA BIO HYDRO 46 "
- 4) Engine oil:
SAE 15W40 according to standard API CH4-CG4-CF
"MINERVA POWER LONG WAY 15W-40 "

ENGINE MAINTENANCE INTERVALS:
See operating instructions of the engine

MACHINE MAINTENANCE INTERVALS

Operating hours	Maintenance works
Every day	<ul style="list-style-type: none"> - Check tight seat of the adjusting joints front side of the trailer coupling/ drawbar - Check function of the safety switches and the red control rod - Check the engine oil level - Check the coolant level - Check the cleanliness of engine radiator - Check the trailer coupling - Check the tight seat of wheel nuts
First time after 4 operating hours	<ul style="list-style-type: none"> - Check the tight seat of all fastening screws - Check the tension of the rotor drive belts - Check the tension of the conveyor
Every 15 operating hours	<ul style="list-style-type: none"> - Lubricate the rotor knives and check condition of wearing rings
Every 50 operating hours	<ul style="list-style-type: none"> - Check the tension of the rotor drive belts - After the first 50 operating hours: Check the tight seat of the 8 fastening screws from rotor bearings - Check knives and counter-knives - Lubricate both rotor bearings - Check ventilation holes under the rotor for free passage - Check if material is wrapped around the bearings and remove - Check infeed rollers - Check the hydraulic oil level - Check the tension of the conveyor
Every 150 operating hours	<ul style="list-style-type: none"> - Lubricate front/rear bearings of conveyor - 1. Replace the hydraulic oil filter (thereafter all 500 operating hours or every 2 years) - Lubricate drive chain of conveyor - Check condition of counter-knives
Every 300 operating hours	<ul style="list-style-type: none"> - Check condition of conveyor and slide plate - Check the battery acid level
Every 500 operating hours	<ul style="list-style-type: none"> - Change the hydraulic oil (or every 2 years) - Replace the hydraulic oil return filter (or every 2 years) - Replace the intake strainer in the hydraulic oil tank

LUBRICATING POINTS



Shut the engine off and remove the key before the lubricating and maintenance works.



LUBRICATION OF KNIVES:

Access to the rotor:

- Loose both locknuts.

- Turn the expulsion channel to the side.

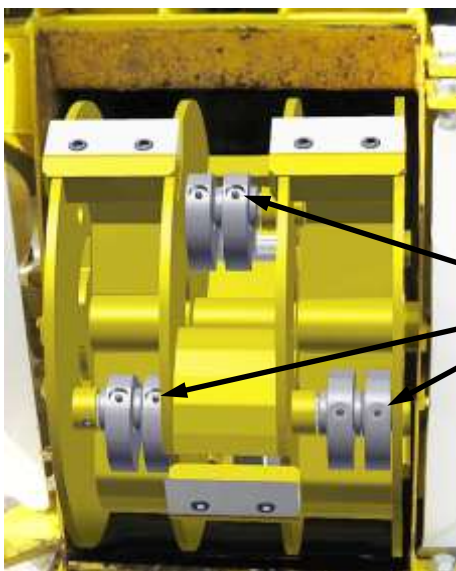

- Clean all grease nipples with compressed air or using a small screwdriver.

- Lubricate all 12 knives.

Note: Do not grease too much, i.e. only about 2 strokes with the grease gun.

An excessive lubrication, the rotation of the rotor would toss the surplus of grease against the inside wall of the chimney, and the chipped material would be expelled with difficulty.

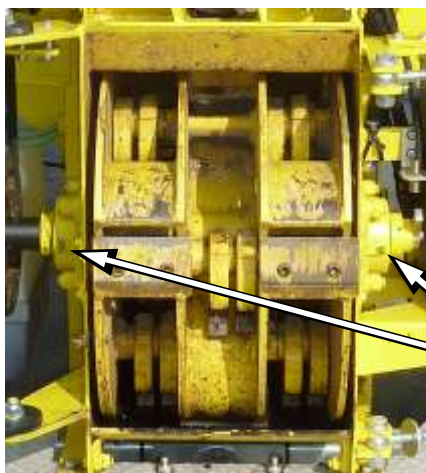

ROTOR BEARING
LUBRICATION

LUBRICATING POINTS

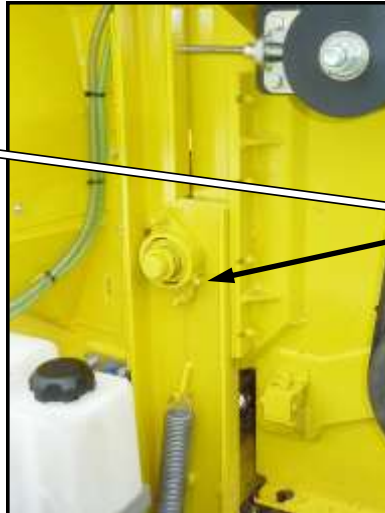

LUBRICATE INFEED ROLLER BEARING
LEFT/RIGHT



LUBRICATE BOTH FRONT CONVEYOR BEARINGS



LUBRICATE BOTH REAR CONVEYOR BEARINGS

LUBRICATE SUPPORT WHEEL



LUBRICATE TRAILER COUPLING

OIL LEVELS



DIP STICK HYDRAULIC OIL



DIP STICK ENGINE OIL



DRAIN HOSE ENGINE OIL
(evacuate the oil with the engine warm)

ADJUSTING THE TENSION OF THE CONVEYOR BELT

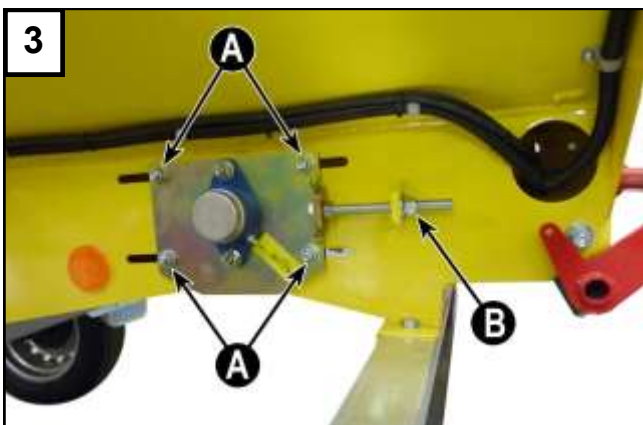

After run-in of the machine, the tension of the conveyor belt must be checked after the first 4 operating hours, and thereafter every 50 operating hours.

- 1** Conveyor belt correctly tensioned
- 2** Conveyor belt loose
- 3** Tension the conveyor belt as follows: Loosen on

both sides of the machine all 4 nuts (A), and tension the conveyor belt with the tensioning screws (B) such that the roller is standing centrally in the window for maximum tension (Fig. 4). Tighten the nuts (A) again. Have the conveyor belt run several times forward and backward, and check for directional stability.

Note: Do not tension the conveyor belt to much; for running correctly the belt does not need excessive tension. Utilise the window for maximum tension (Fig. 4).



Attention: Avoid infeed of roots with earth still sticking to it. This might accumulate in the front drive roll and block the conveyor belt.

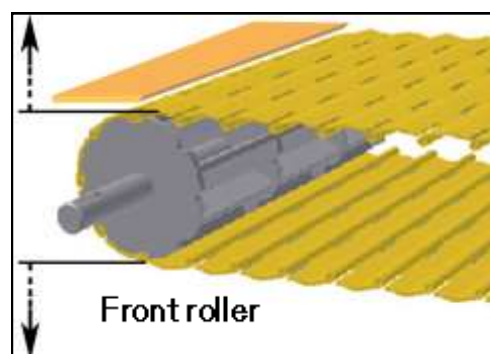

CHECK CONDITION OF CONVEYOR BELT AND SLIDING PLATE

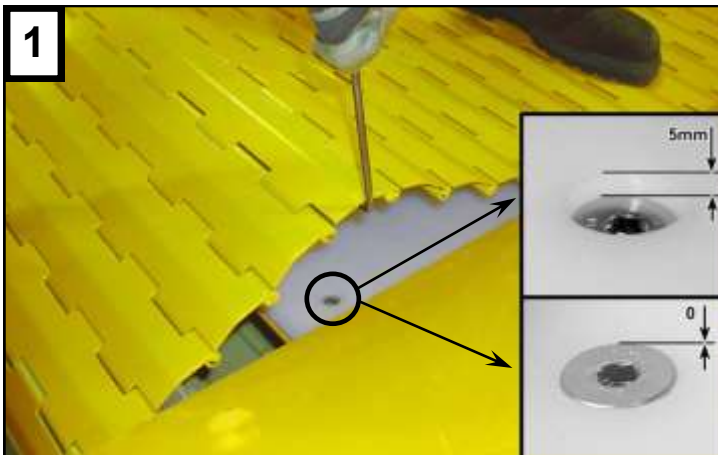

For checking the conveyor belt and the self-lubricating polyethylene plate, completely relax the conveyor belt and lift it with a hook. The following parts have to be checked:

- 1 Thickness of the sliding plate above the 4 fastening screws
- 2 Condition of the belt rods

VENT OPENINGS UNDER THE ROTOR

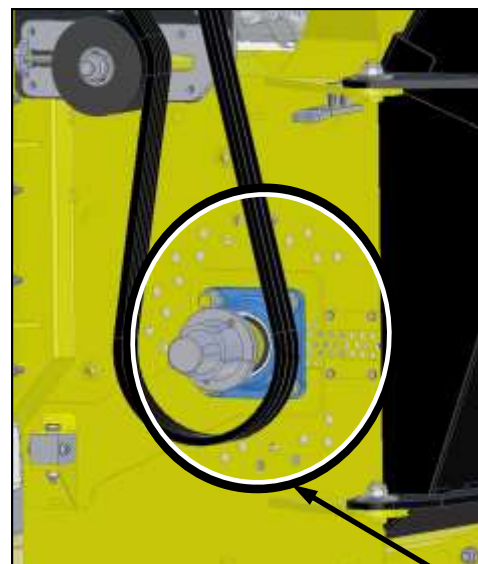
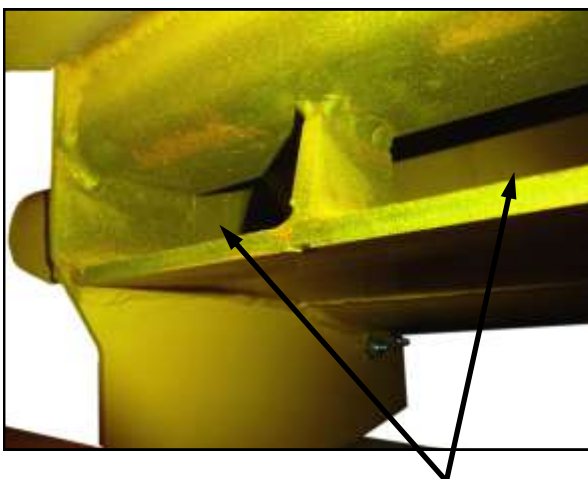

For improving the rotor ventilation and the material expulsions, the **PUMA** is fitted with another vent opening under the rotor, additionally to the standard two lateral vent openings.

These air intakes must be checked for cleanliness and free passage in regular intervals.

Maintenance

KNIFE AND INSERTS REPLACEMENT

Remove ignition key before the maintenance works.

Tool to lock rotor

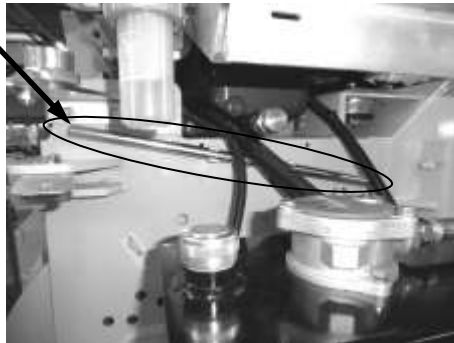

To remove knives and hammers

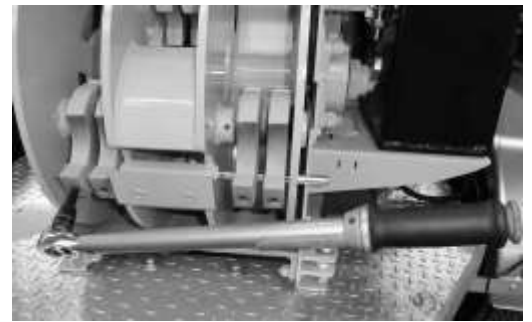

Screwlock knives and hammers:
157 N.m.

- Ex works, all 6 fastening screws of knives and inserts secured without screwlock medium, with a torque of **157 Nm (16 M.kg)**, and therefore must be loosened using a corresponding tool.
- Open the expulsion channel (see page 28).
- Unsrew all fastening screws from knives and inserts. Do always use new screws of **class 12.9** for installing knives and inserts.

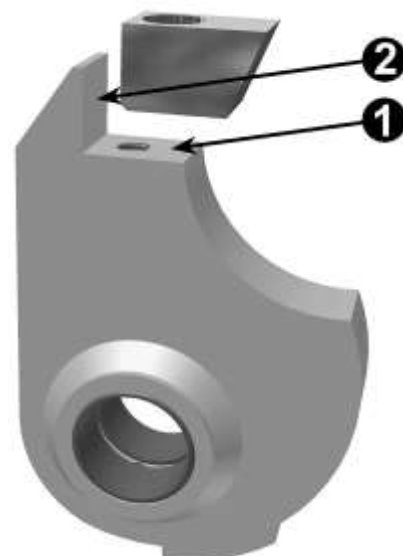
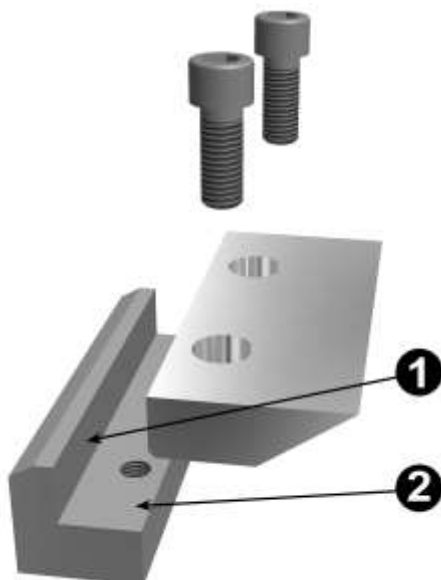

SAELEN[®] TS INDUSTRIE[®]

Maintenance

- Install new or sharpened knives of identical weight.

IMPORTANT: Only a specialist is allowed to sharpen the knives on an appropriate machine and not on a portable grinding machine.

Also it is to be observed that the edge of the knives is to be sharpened at an angle of 35°.

After sharpening, the length **A** must not fall below 50 mm (a new knife has a length of **60 mm**).

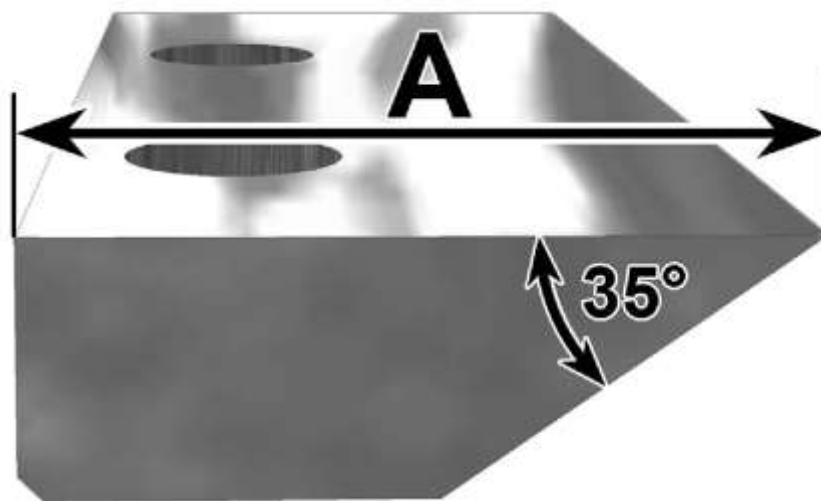

Do only use screws of type TCHC 12 X 40 class 12.9

- Tighten screws of class 12.9 applying a torque of 157 Nm and ensure correct seat of knives and inserts.

Tightening with the correct torque is important to prevent the screws from coming loose.

- Lubricate the knife bolts (for each grease nipple aprox. 2 strokes with the grease gun).
- Close expulsion chimney and hoods again.
- Start the engine and have it run until it has reached operating temperature.
- Accelerate the engine up to maximum speed and check if the machine produces unusual vibrations.

CHECK COUNTER-KNIFE

Remove ignition key before the maintenance works.

- Unscrew retaining screws $\varnothing 10$ (1) at both ends of the counter-knife.
- Unscrew both locking screws $\varnothing 8$ (2).
- Pull the counter-knife partially out of the housing. If the edge is worn, pull the counter-knife out of the housing, give it a quarter turn, such that the new edge is pointing towards the knives, and push the counter-knife back into the housing.

(The counter-knife can be pulled out of the housing on the right side as well as on the left side)

(All 4 edges can be utilised)

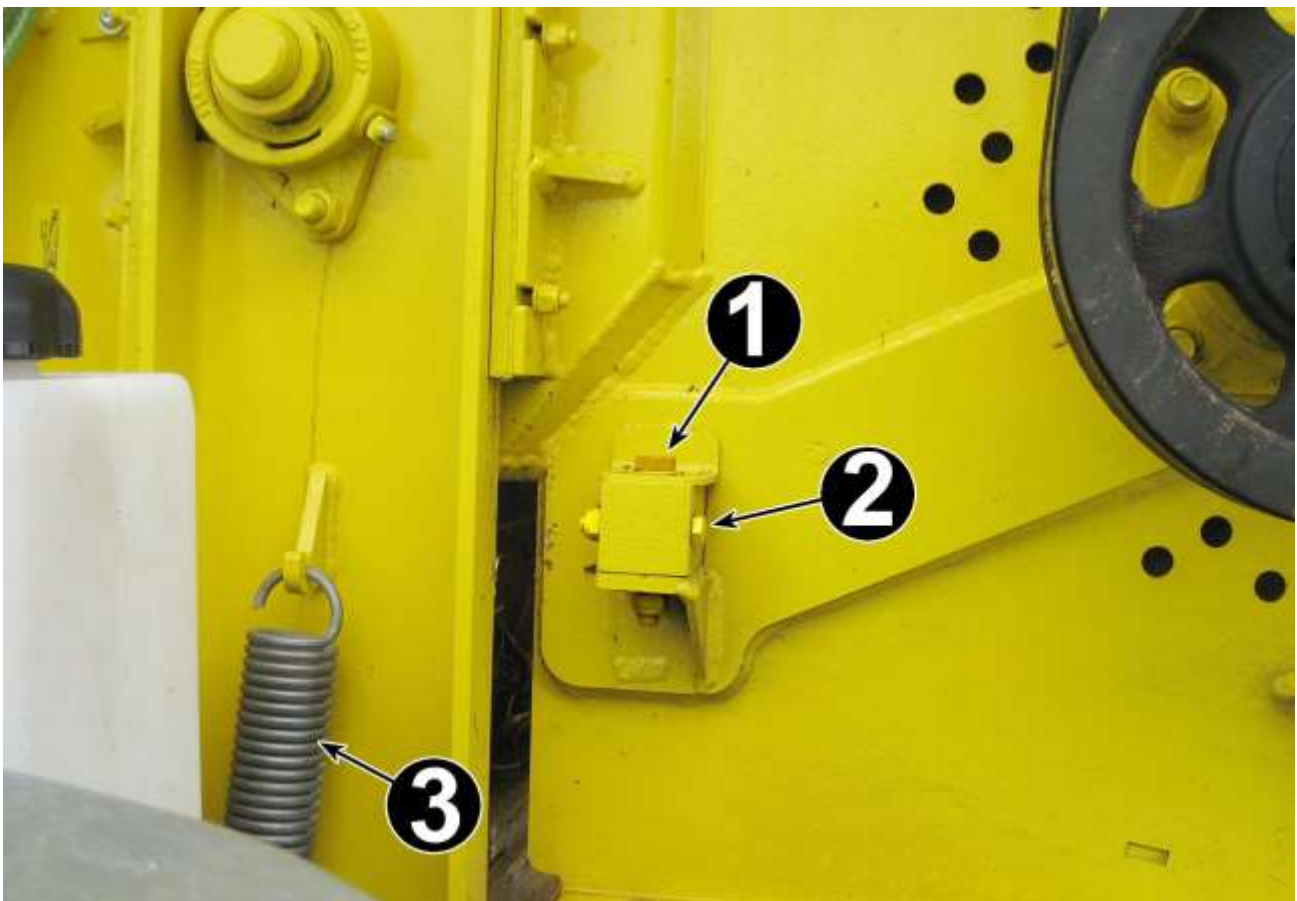

PRESSURE OF THE INFEED ROLLER ONTO THE MATERIAL

The pressure of the infeed roller onto the material is produced by two springs (3) on each side of the machine.

TENSIONING THE V-BELT FOR THE ROTOR DRIVE

The tension of the V-belts is ensured by a belt pulley(1).

The adjustment of the V-belt tension is carried out by loosening the nut (4) on the belt pulley as well as the locknut (3) and readjusting the belt pulley with help of the screw (2).

ONLY TRAINED PERSONNEL CAN CARRY OUT THIS WORK.

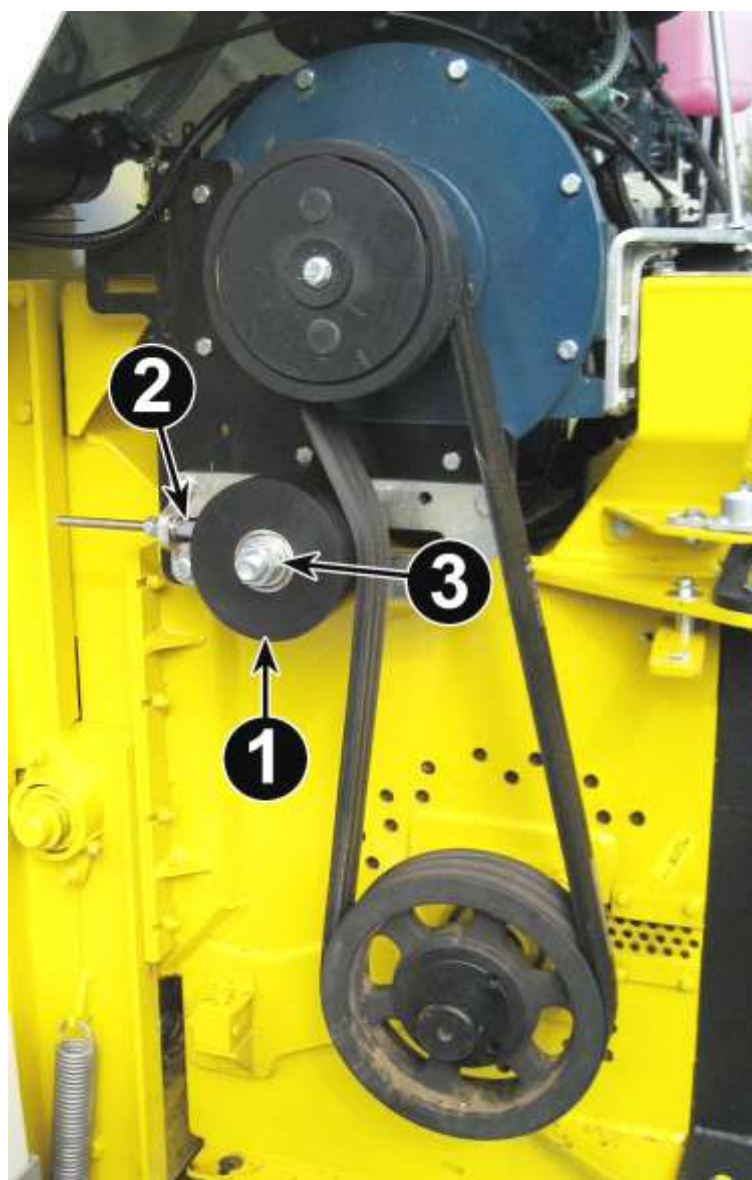

TENSIONING THE DRIVE CHAIN FOR THE INFEED ROLLER

- Remove the protective hood, loosen the two screws (1) and unscrew by approx. 1 turn.
- Loosen the locknut (2)
- Slowly turn the tensioning screw (3) and move the hydraulic motor with pinion down until the chain is **slightly tensioned**.
- Correctly retighten locknut (2) and both screws (1).
- Install the protective hood.

ONLY TRAINED PERSONNEL CAN CARRY OUT THIS WORK.

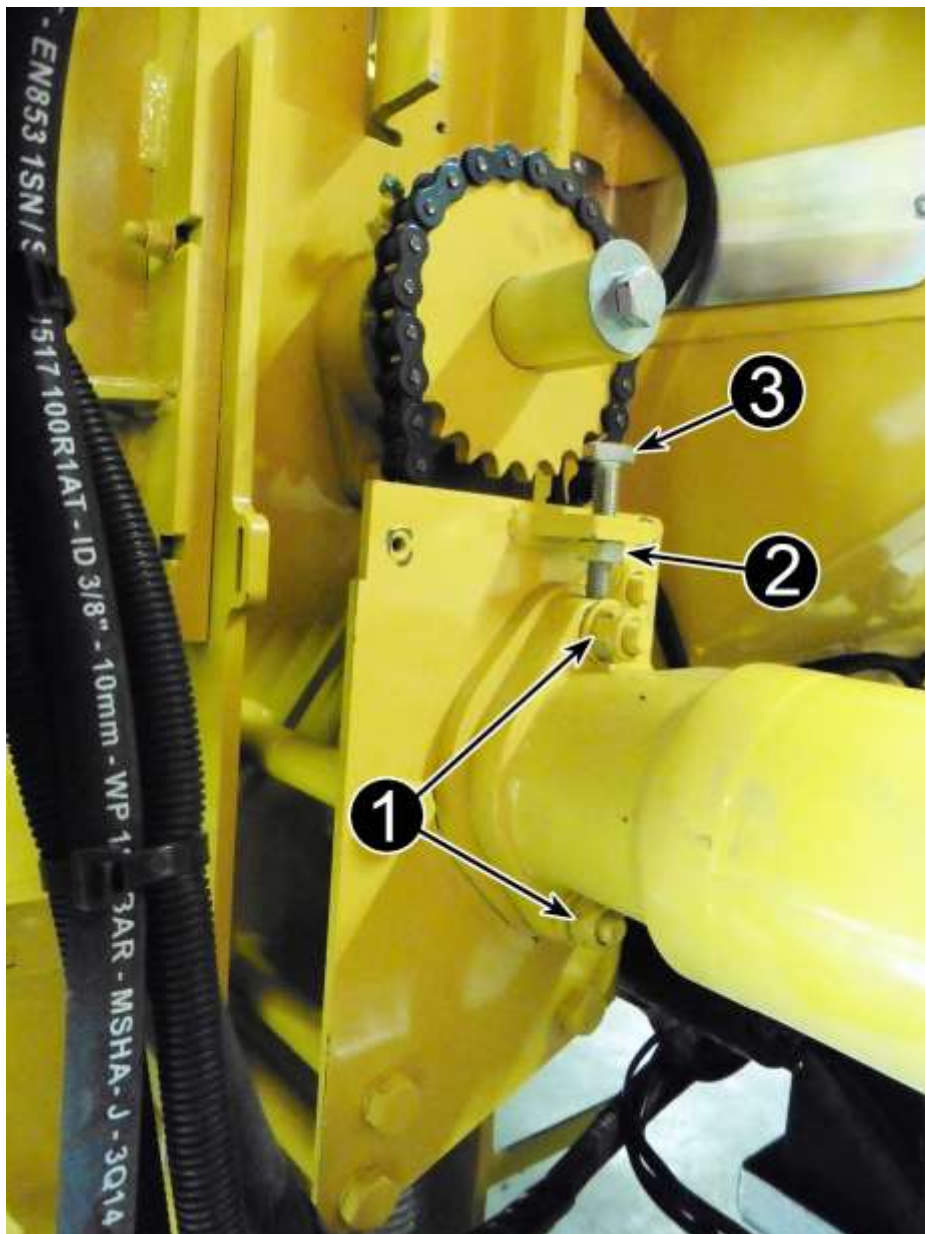

BRAKES ADJUSTMENT

The adjustment of the brake system is to be checked after 300 kilometres and thereafter in regular intervals.

Move the brake lever to position „0“



Check the clearance between catch and slide piston.
The clearance must amount to approx. 2 mm.

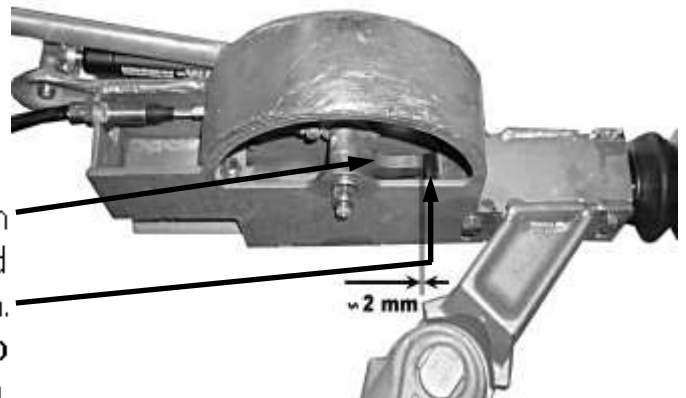

For adjusting the clearance, loosen the locknut and correspondingly turn the nut on the steering linkage.

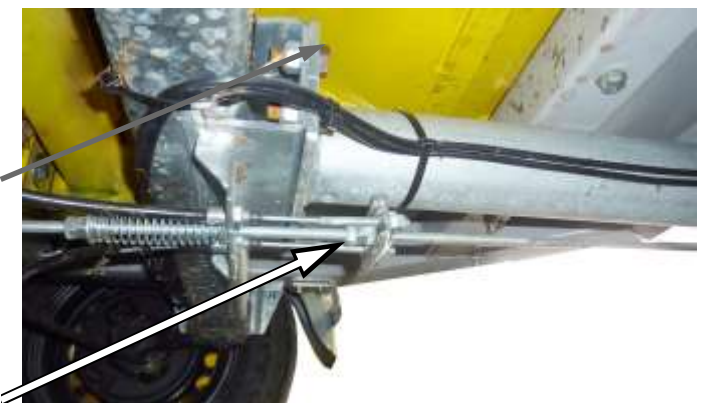

CONTROL ELEMENT OF THE ENGINE

- A:** Green warning light - operating control light (OK)
- B:** Warning light battery charge control
- C:** Warning light oil pressure
- D:** Warning light coolant temperature
- E:** Preheating light (8 seconds)
- F:** Ignition lock

In case of a defect, the engine is automatically shut off, and the warning lights C and D light up.

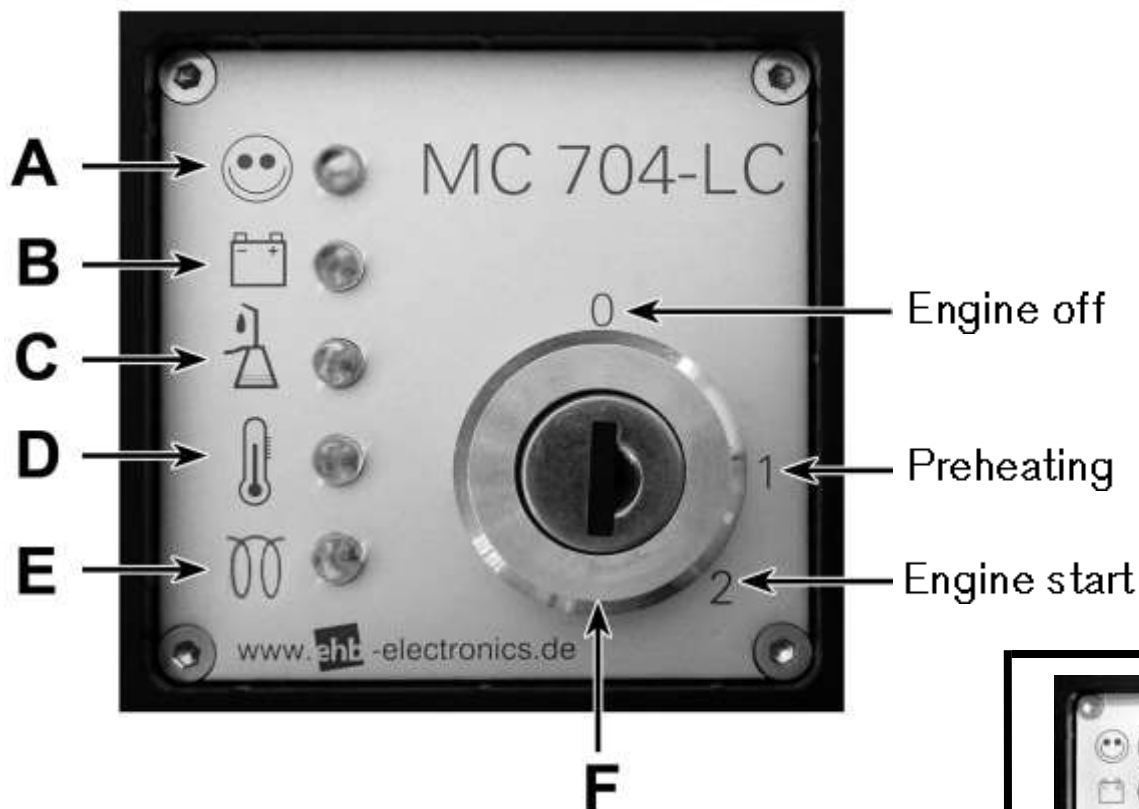

Do not put the contact key on a heavy bunch of keys, this might produce disconnection of the ignition during the operation.

PILOT SYSTEM

AVAILABLE FUNCTIONS

1. Continuous indication of the engine speed
2. Continuous indication of the rotor speed
3. Continuous indication of the daily operating hours
4. Continuous indication the total operating hours
5. INDICATION FOR OPERATION AND OF THE PULSES FROM THE ROTOR ENCODER WITH GREEN LED
6. INDICATION OF ERRORS WITH RED LED
7. Hydraulic test: a fast forward and backward travel speed serves for testing the hydraulic system
8. A fast forward movement of the infeed roller serves for testing the No Stress System
9. 3 No Stress (Vario Stress) Options for choosing the type of wood
10. Service management : Intervals for oil change
11. Belt slip, clutch and hydraulic coupling system (ideal for rental equipment)
12. CUT-OUT FUSE FOR ENGINE AND START INTERLOCK IF HOODS ARE OPEN
13. ERROR MEMORY
14. 21 Machine types are lodged in the memory
15. 4 optional selectable languages: English, French, German and Spanish



DESCRIPTION AND OPERATION

DESCRIPTION

LED:

- Green - continuous: ON
- Green - flashing: Pulses from rotor encoder
- Red - continuous: Engine hood or access to chimney open

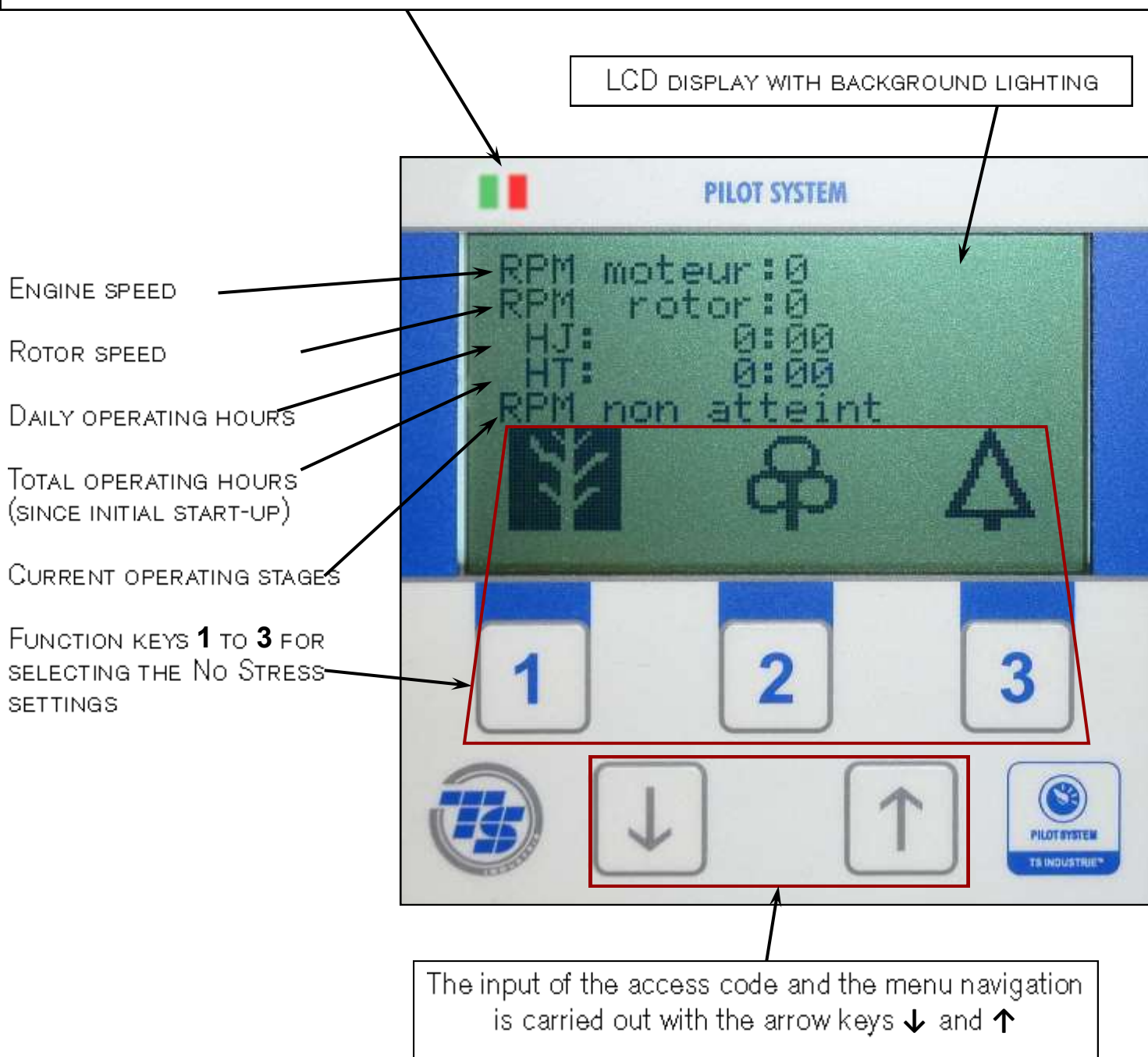

It is strictly prohibited to change the factory settings of the Pilot System. The programming person is responsible for any change of the parameters outside the works of TS Industrie.

THE VALUES INDICATED ON THE FOLLOWING PAGES ARE REFERENCE VALUES ONLY

SELECTING NO STRESS SETTINGS

The Pilot System has 3 No Stress settings

Above each key there is a symbol for the according setting, showing a black background when selecting this setting.

Key 1 for wooden waste: Utilises an amplified engine speed



Key 2 for average waste: Utilises a medium speed range. Branches and coniferous wood can be processed



Key 3 for coniferous wood and vegetation, e.g. coniferous wood and humid green wood

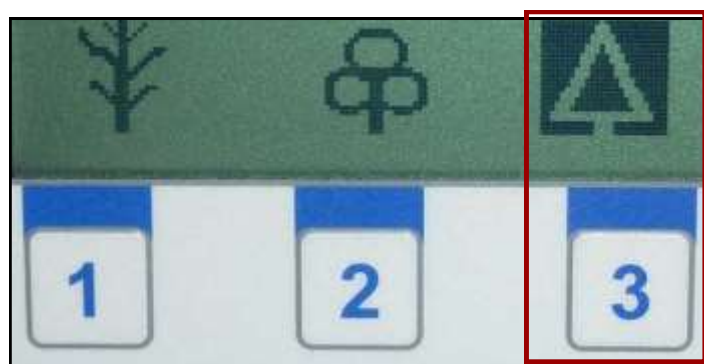

In case the settings shall be changed during the work, it is required to press the yellow button on the infeed hopper for re-starting the infeed rollers.

STANDARD OPERATION AND OVERSPEED

The speed of the rotor is the essential data for the functional check of the machine.

The indication **RPM too low** shows that the engine speed is insufficient for continuous material infeed to the rotor.

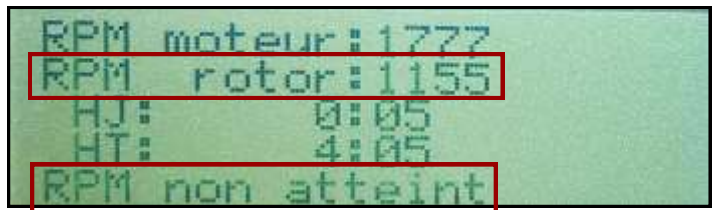

Adjust engine to max. speed. A **Smiley** is shown as soon as the minimum speed is reached for connecting the infeed roller. Now the **yellow** button can be activated.

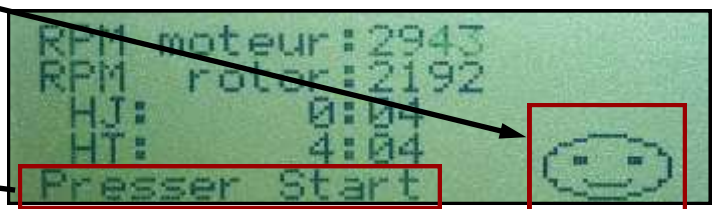

As soon as the infeed roller is rotating and the rear red control rod is activated, appears the message **infeed stop**.

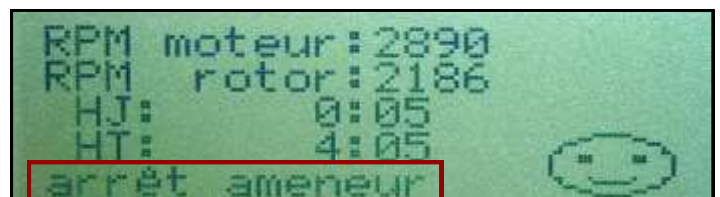

If the rotor speed is too high, the infeed roller is automatically stopped to protect the machine. At the same time appears the symbol Attention as well as the message **overspeed**.

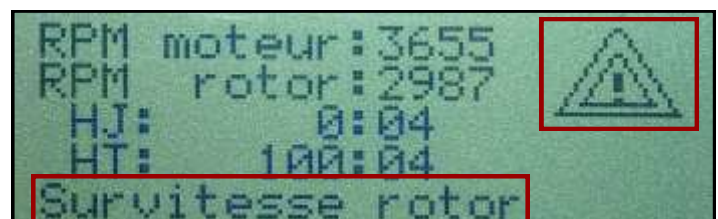

After having removed the cause for the overspeed it is required to reduce the engine speed to idle running, then increasing it again to max. Speed, to allow the infeed roller to re-connect.

SLIP FUNCTION

The Pilot System controls the slip between the belt pulleys of rotor and engine by continuous comparison of both speeds. For the protection of V-belts, centrifugal clutch and hydraulic coupling, a slip of one per cent is admissible. If slip increases to over one per cent, the engine is shut off and the following messages appears on the display.

Different reasons for slip:

- Rotor blocked
- V-belt loose
- Coupling worn

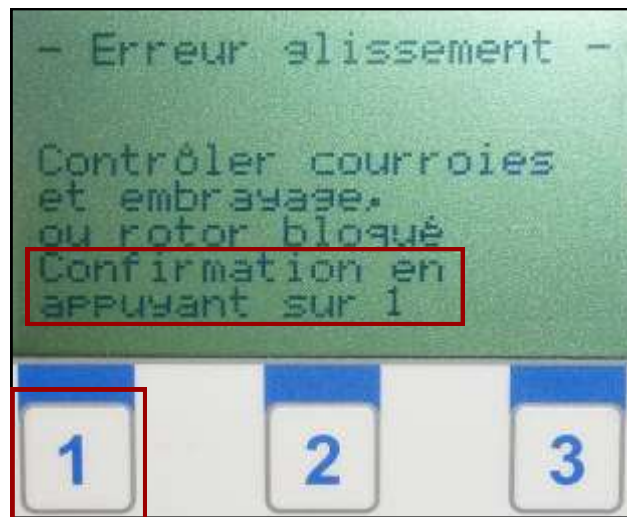

Note: Slip can be produced if the machine from standing is accelerated very slowly.

After stopping/checking the drive press key 1 to be able to continue work.

Date and time of this message are saved in the memory of the Pilot System, and can be read by the dealer.

Access to the CUSTOMER Parameters Code 3003

1

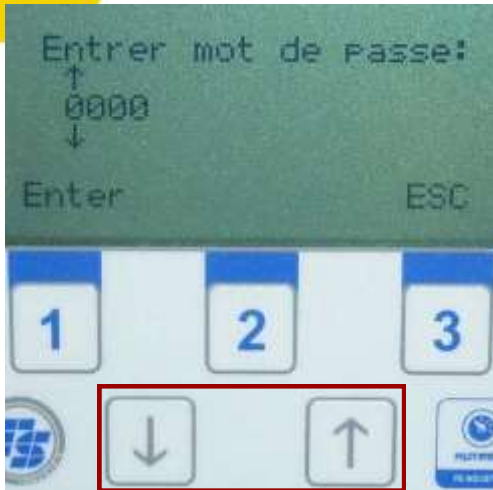

Keep key ↓ and ↑ pressed for 4 seconds.

2

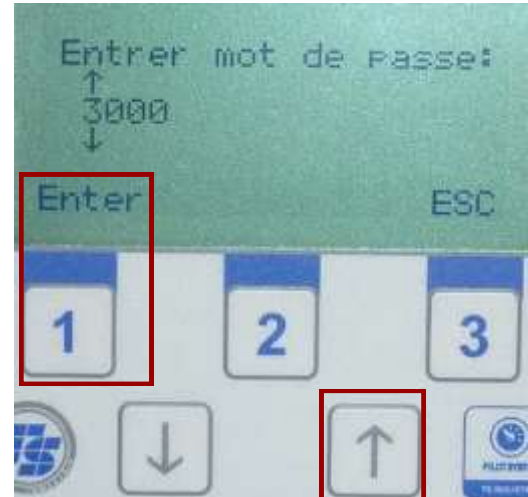

Press key ↑ 3 times until the number 3 is displayed, than confirm with key 1.

3

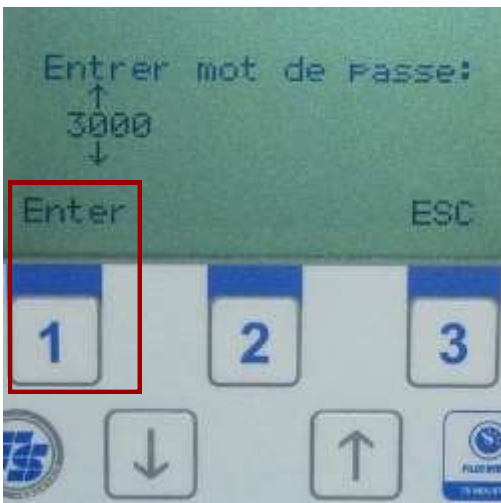

Press key 1 for confirmation and go to the first 0.

4

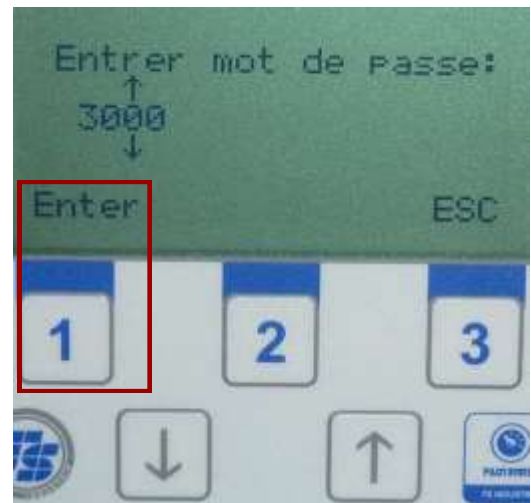

Press key 1 again for confirmation and go to the second 0.

5

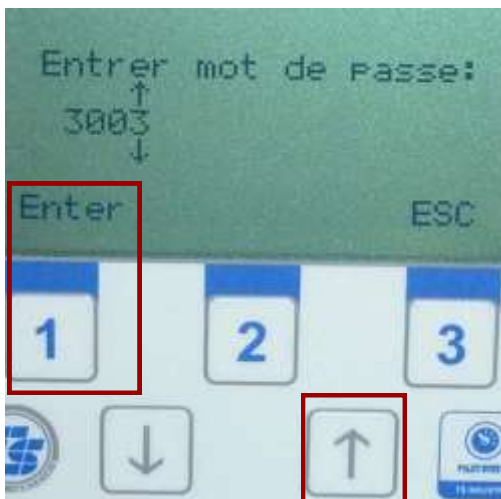

Press key ↑ 3 times until the number 3 is displayed, the confirm with key 1.

6

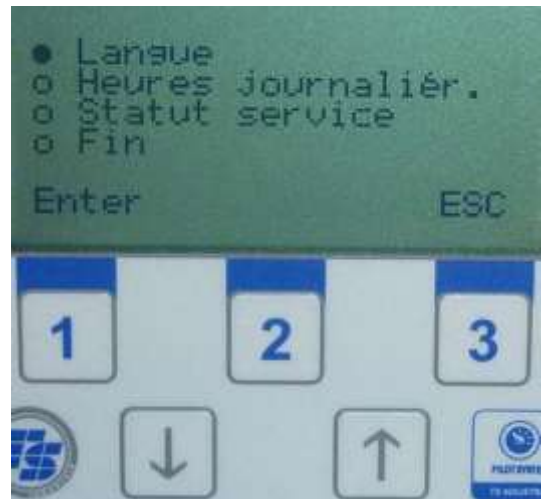

Now, the user has access to different functions and **END** navigation.

Reset of the daily operating hour counter



Press key ↓ and put the cursor on **Daily oper. hrs.**



Press key **1** to confirm deletion of the daily operating hours.

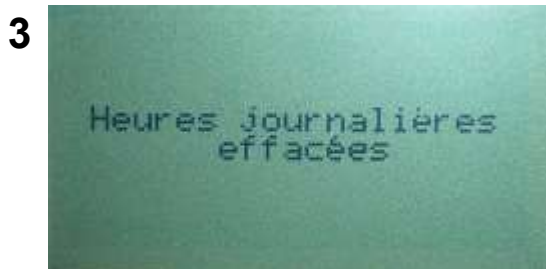

The process is indicated with a corresponding message.

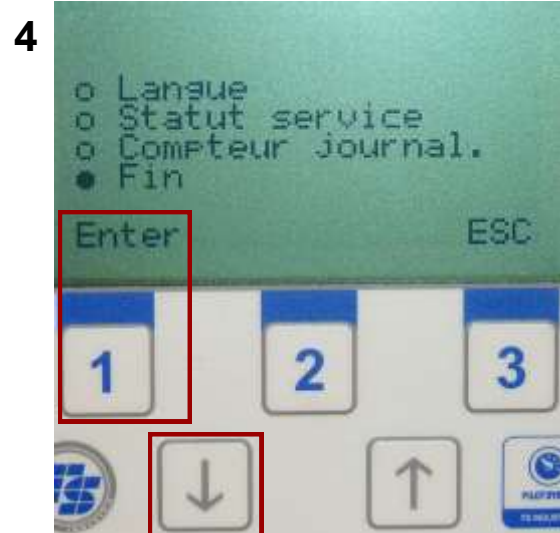

Press key ↓ and put the cursor on **End**. Confirm with key **1 Enter**.

Overdue service and further service information (engine oil change)

When starting the machine, the system shows a warning message and a corresponding symbol as soon as maintenance is due or overdue.

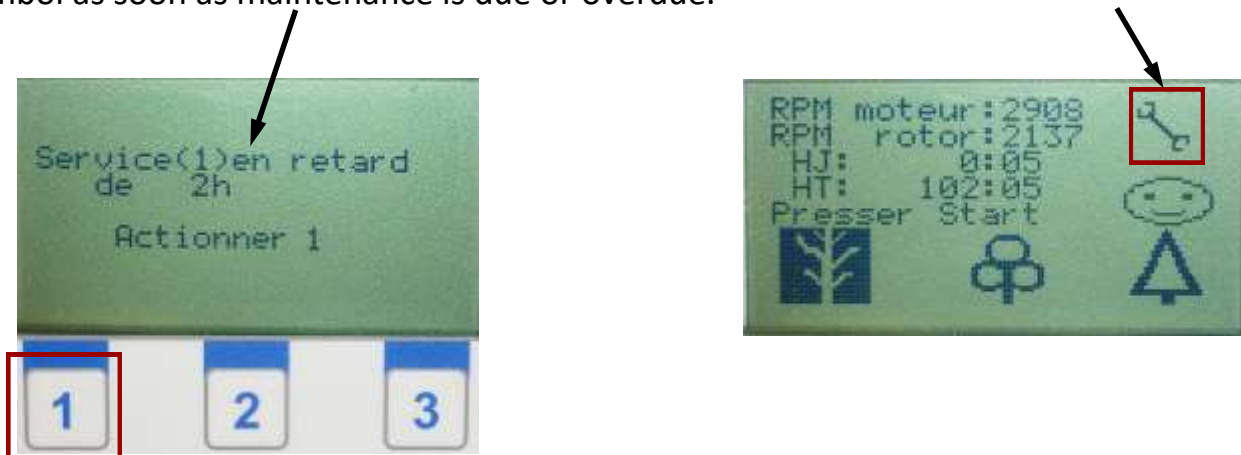

Agree with your dealer a date for an oil change. The message is saved in the Pilot System. Press key 1 for confirming the message and to be able to continue work.



Press key ↓ or ↑ once or twice for displaying the next oil change or service. Contact your dealer to agree a date.

Description and operation

Rotor speeds of the No Stress settings

(The examples are reference values only)

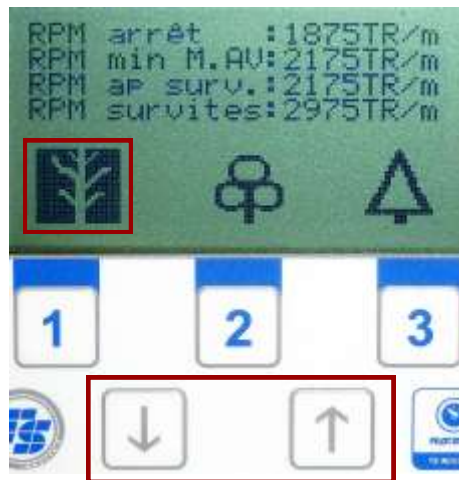

Press key ↓ or ↑ once or twice at any time for indication of the **rotor speed** for the selected NO Stress setting:

Example setting 1:

Minimum: Speed below 1875 rpm. The infeed roller is disconnected.

Return: As from a speed of 2175 rpm. The infeed roller is restarted.

Normal: After an overspeed of the engine, the speed of the rotor must be reduced to below 2175 rpm for the infeed roller to reconnect.

Over: Overspeed. The infeed roller is switched off at a speed of 2975 rpm.

Attention:



It is strictly prohibited to change the factory settings of the Pilot System. The programming person is responsible for any change of the parameters outside the works of TS Industrie.

Hood safeguard

An open or incorrectly closed hood is indicated by a **red LED** and a corresponding message. The safety system shuts the engine off and impedes a restart. In this case, close the affected hood correctly and then press key **1**. The message disappears.

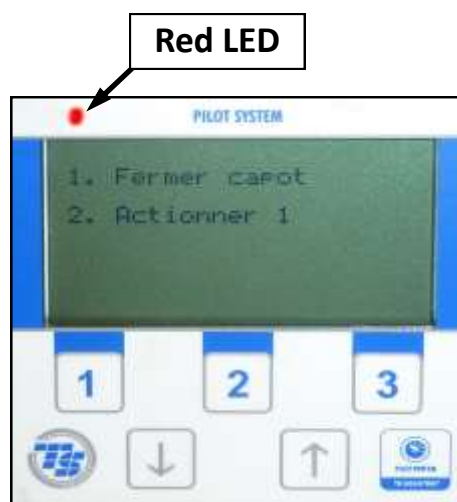

Rotor speed encoder pulses

A permanently shining **green LED** shows that rotor and system are operating. The LED starts flashing when it receives a signal from the speed encoder M18 on the rotor. The frequency of the flashing changes with the speed of the rotor.

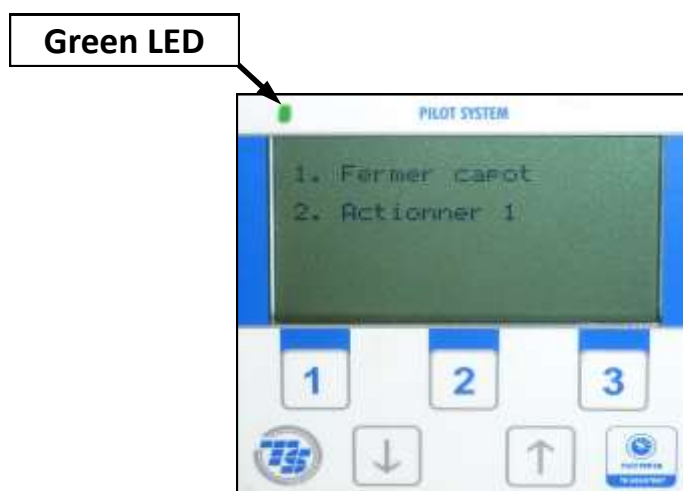

TANKS

The machine is fitted with two tanks:

Hydraulic oil tank with a capacity of 15 liters, consisting of:

Oil dip stick with lid

Return oil filter

Intake filter

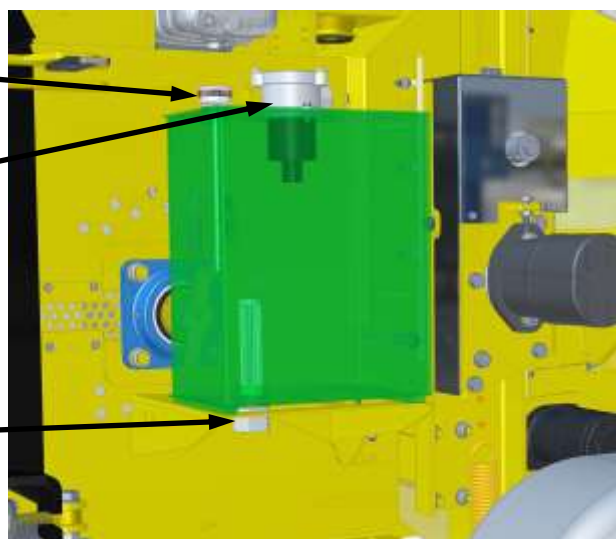

Fuel tank with a capacity of 30 litres



HOOD AND EXPULSION CHANNEL SAFEGUARD

The machine is fitted with a safeguard for hood and expulsion chimney:

This safeguard consists of two proximity sensors. One (1) is located at the front side from the expulsion chimney and the other (2) at the front left side of the engine bracket. The electric switching contact is established when the sensor approaches the magnet (2) on the yellow hood. When opening the hood or the expulsion chimney the contact is interrupted and the engine is shut off.

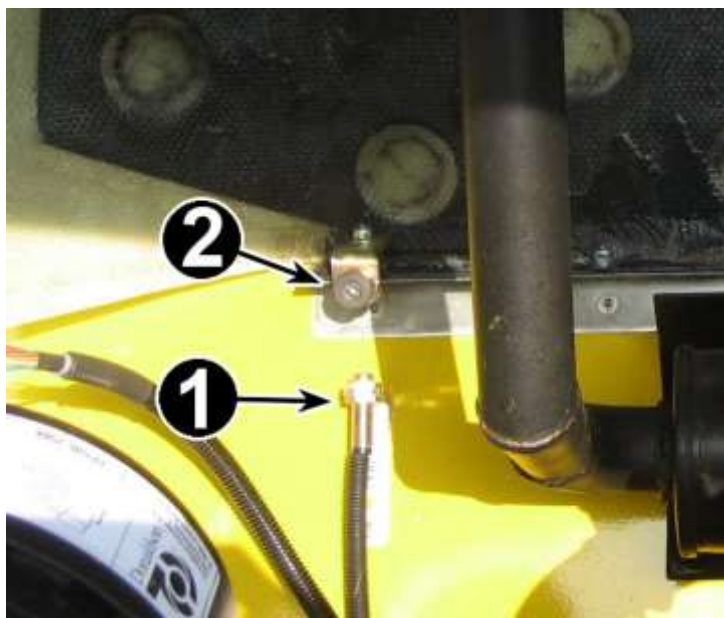

The proximity switch must not enter in contact with the magnet. The distance between sensor and magnet must amount to 6 mm +/- 5.

EMERGENCY STOP SWITCH

The machine is also fitted with two emergency stop switches, one on each side of the machine.

When activated, these switches have the following functions **(the Pilot System is switched off)**:

1. Diesel engine shut off
- 2) Infeed roller shut off



DESCRIPTION AND OPERATION

PROXIMITY SENSOR AND FUSE

The proximity sensor M18 (Ø18) at the end of the rotor shaft captures the speed and sends it to the Pilot System.

The distance between sensor and metal pin opposite of the V-belt pulley must amount to **4 mm ^{+/-1}**.



If after the start the engine is shut off again after some seconds and on the Pilot System appears the message "Slip error", it is required to find the cause for the error: *Rotor blocked by chipping remains, loose or broken V-belts, defective coupling, defective sensor M18.*



BLADE-TYPE FUSE
TYPE U 40 A.



One blade-type fuse **40 A** is located in the fixture on the battery cable beside the starter motor.

EXPULSION CHANNEL

After opening the latch **(1)** the upper part of the expulsion chimney can be turned by 90° to the left and by 90° to the right.



In this chapter we have compiled a list of possible errors, their causes and their solutions. In case an error appears, which is not listed in chapter "Troubleshooting", please contact your dealer. Have your operating manual and the serial number of your machine on hand.

FAILURE	CAUSE	REMEDY
The engine is shut off and the Pilot System shows the message "Slip error".	-See page 41	
Not possible to connect the Pilot System	- Emergency stop switch activated	- Unlock switch
The engine does not start	<ul style="list-style-type: none"> - Emergency stop switch activated - Hood open - Hood/expulsion channel safeguard wrong adjusted or defective - 40A-fuse defective - Battery empty - Supply cable damaged 	<ul style="list-style-type: none"> - Unlock switch - Check locking of the hoods - Check sensor (see page 51) - Replace fuse (see page 53) - Charge or replace battery - Check electric circuits
Reduced engine output	<ul style="list-style-type: none"> - Radiator clogged - Knives/Counter-knife blunt - Fuel filter clogged 	<ul style="list-style-type: none"> - Clean radiator - Sharpen or replace knives/inserts - Replace filter

FAILURE	CAUSE	REMEDY
The engine shuts off and cannot be restarted	<ul style="list-style-type: none"> - Hood/Expulsion channel not correctly locked - Hood/Expulsion channel safeguard defective - Fuel tank empty 	<ul style="list-style-type: none"> - Check locking of the hoods/channel - Check sensor (see page 51) - Fill with fuel
No forward or backward motion of the conveyor belt or of the infeed roller	<ul style="list-style-type: none"> - Regulating screw at infeed completely screwed down - Hydraulic motor or pump defective - Oil deficiency in hydraulic tank 	<ul style="list-style-type: none"> - Loosen the regulating screw - Check defective part or replace - Check oil level
The machine is chipping with difficulties	<ul style="list-style-type: none"> - Knives/Inserts blunt - V-belt damaged or loose 	<ul style="list-style-type: none"> - Sharpen or replace knives/inserts - Replace or tension V-belt
The infeed roller does not regulate, neither under the switch-on limit of the Pilot System	<ul style="list-style-type: none"> - Failure of the electric or hydraulic installation 	<ul style="list-style-type: none"> - Contact dealer

Specifications

PUMA 35 D

Performance:	160 mm
Hourly output:	27 m ³ /h
Length:	4.45 m
Width:	1.70 m
Height:	2.36 m
Weight:	1280 kg
Number of inserts:	12
Number of knives:	6
Rotor diameter:	560 mm
Rotor weight:	150 kg
Rotor width:	400 mm
Engine power:	35 PS Kubota V1505 4 cylinders
Fuel tank capacity:	30 l
Engine speed:	3000 rpm (idle speed approx. 3150 rpm)
Rotor speed:	2000 rpm
Overload protection:	Yes
Hydraulic supply:	Yes
Hydraulic oil tank capacity:	15 l
Hydraulic pressure:	120 bar
Test drive:	Yes
Noise protection:	No
Number of wheels:	2
Tyres:	165R13
Tyre pressure:	3.5 bar
CO ₂ REDUCTION:	No

Hydraulic connections



① 950 mm ② 550 mm ③ 550 mm ④ Pres. 1850 mm ⑤ Ret. 1500 mm Asp. 1260 mm

Hydraulic Circuit Diagram

Hydraulic Circuit Diagram PUMA

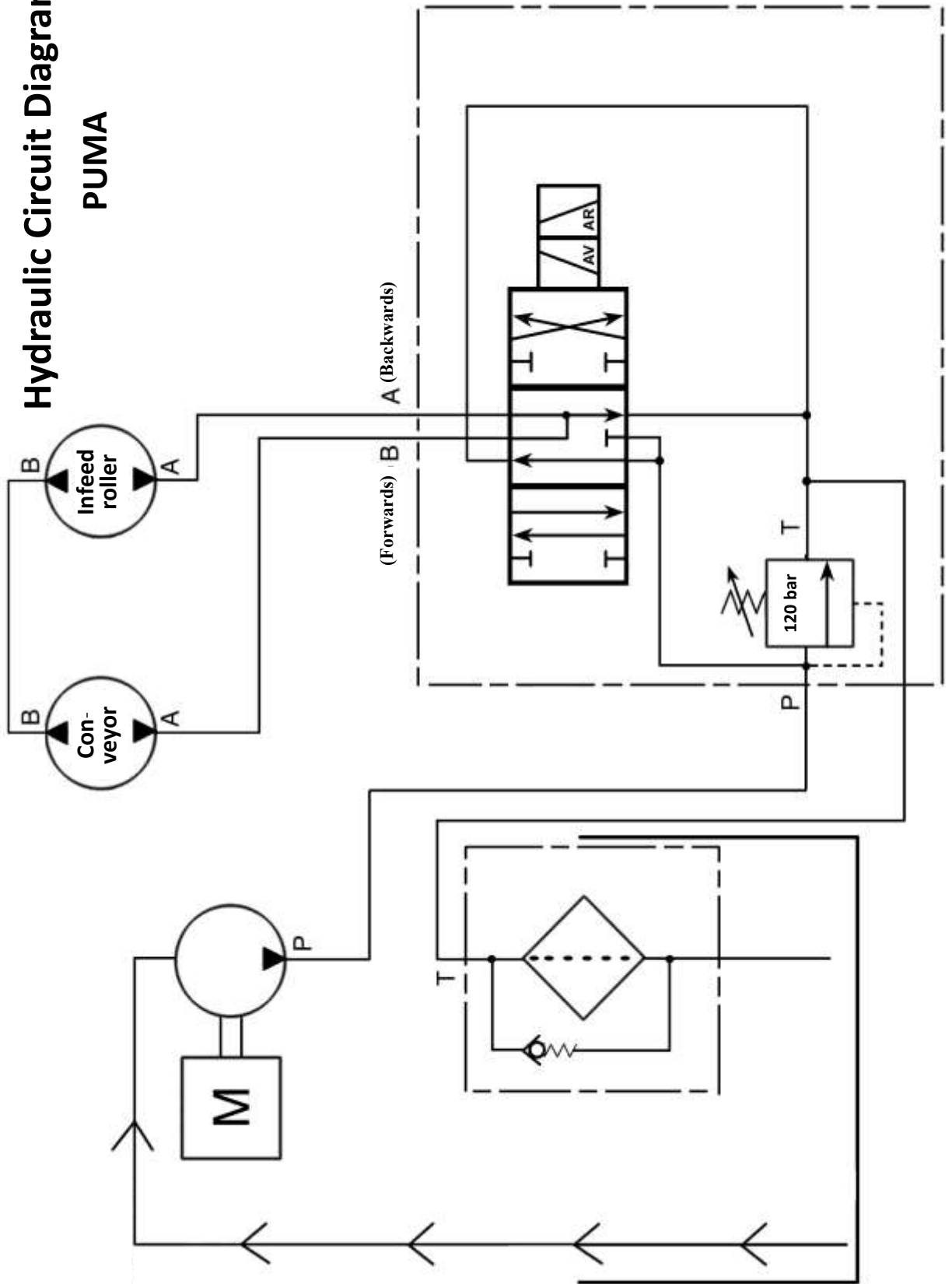

Electric Circuit Diagram Engine 1/2 EHB2275

bl	-	Blau / Blue
br	-	Braun / Brown
ge	-	Gelb / Yellow
gr	-	Grau / Grey
gn	-	Grün / Green
rt	-	Rot / Red
sw	-	Schwarz / Black
vio	-	Violett / Purple
we	-	Weiß / White

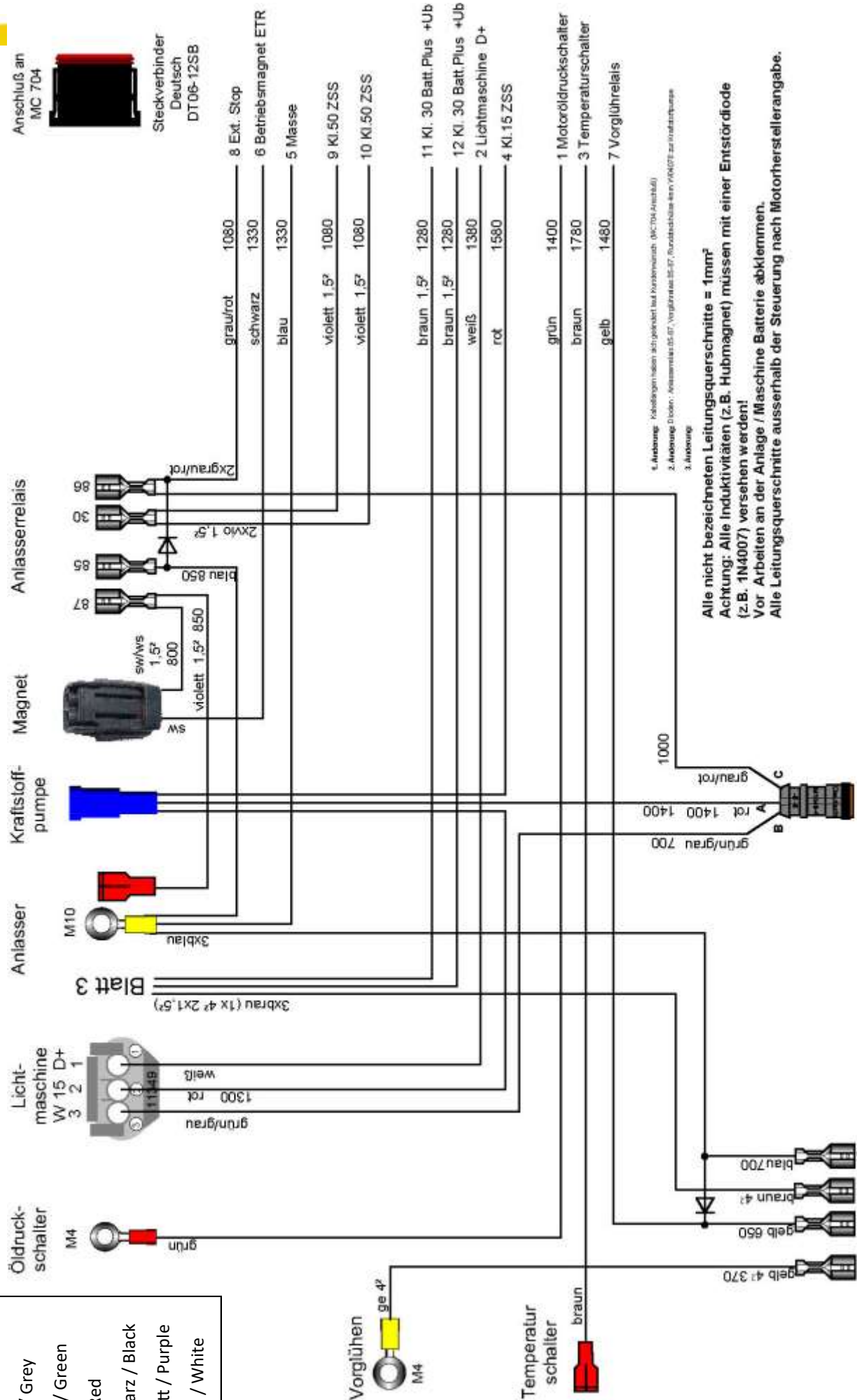

Anschluß an MC 704

Steckverbinder Deutsch DT08-12SB

8 Ext. Stop	1080	grau/rot
6 Betriebsmagnet ETR	1330	schwarz
5 Masse	1330	blau
9 Kl.50 ZSS	1080	violett 1,5"
10 Kl.50 ZSS	1080	violett 1,5"
11 Kl. 30 Batt.Plus +Ub	1280	braun 1,5"
12 Kl. 30 Batt.Plus +Ub	1280	braun 1,5"
2 Lichtmaschine D+	1380	weiß
4 Kl.15 ZSS	1580	rot
1 Motoröldruckschalter	1400	grün
3 Temperaturschalter	1780	braun
7 Vorglührelais	1480	gelb

1. Auslegung: Kabelabgängen folgen sich gegenüber laut Kundenwunsch (MC704-Anschluß)
 2. Auslegung D oben: Anlassenrelais 05-07, Vorglührelais 05-07, Betriebsmagnet kein 1N4007 zur Induktionsunterdrückung
 3. Auslegung

Alle nicht bezeichneten Leitungsquerschnitte = 1mm²
Achtung: Alle Induktivitäten (z.B. Hubmagnet) müssen mit einer Entlastdiode (z.B. 1N4007) versehen werden!
Vor Arbeiten an der Anlage / Maschine Batterie abklemmen.
Alle Leitungsquerschnitte ausserhalb der Steuerung nach Motorherstellernangabe.

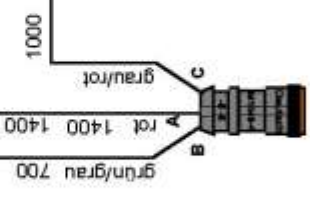

Übergabe HCflex

Electric Circuit Diagram Engine 2/2 EHB2275

bl	-	Blau / Blue
br	-	Braun / Brown
ge	-	Gelb / Yellow
gr	-	Grau / Grey
gn	-	Grün / Green
rt	-	Rot / Red
sw	-	Schwarz / Black
vio	-	Violett / Purple
we	-	Weiß / White

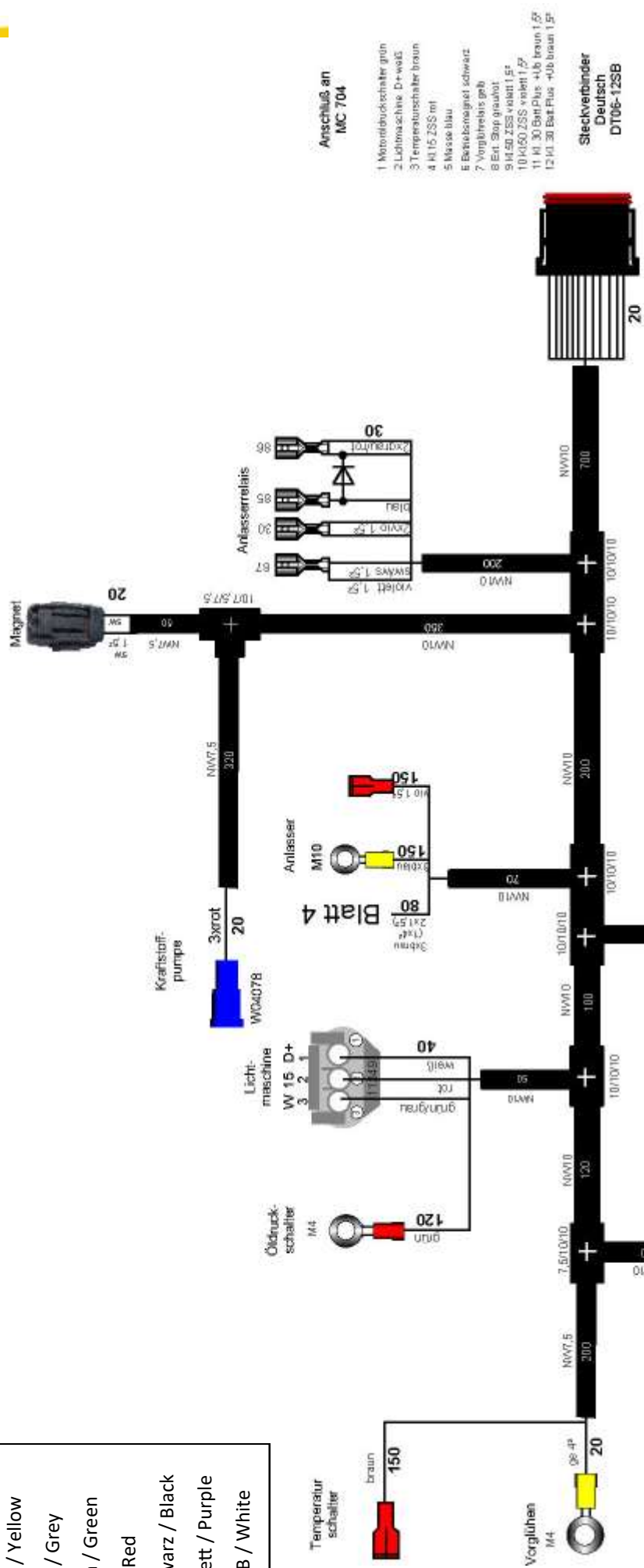

Alle Weillrohrenden mit Schrumpfschlauch versehen

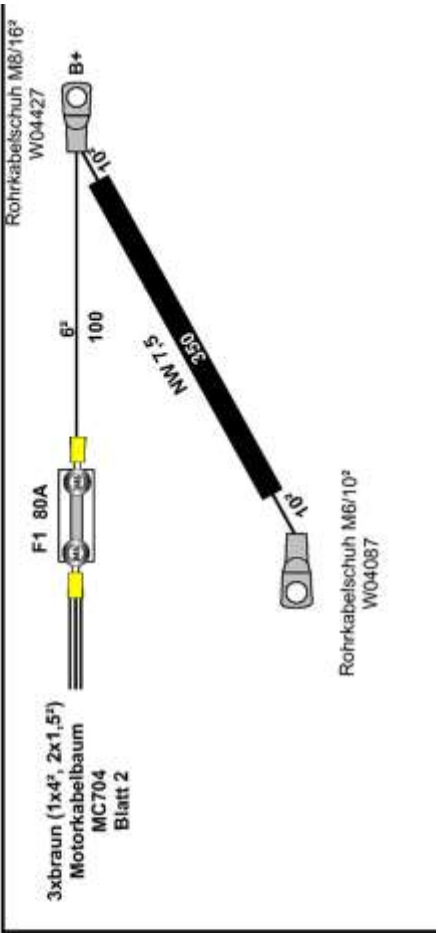

Saelen

3 rue Jules Verne
L'Orée du Golf - BP 17
59790 Ronchin
Tél : + 33 (0)3 20 43 87 87
Fax : +33 (0)3 20 34 12 73
contact@saelen.fr www.salen.Fr

Pièces détachées

Tél : + 33 (0)3 20 43 24 89
Fax : +33 (0)3 20 34 12 73

TS Industrie

TS Industrie GmbH
Weserstr. 2
D - 47506 Neukirchen - Vluyn (Germany)
Tel.: +49 2845 / 9292-0
Fax: +49 2845 / 9292-28
kontakt@ts-industrie.de
