

DZC 450					
NO	MMA 01 490 100	REV	1	DATE	2020/05/29

Pos	Qté	Nom	Description
12	1	000 001 321	VERPAKKING
110	1	MMA 01 490 110	DZC 450-MONTAGE GESTEL
120	1	MMA 01 490 120	DZC 450 MONTAGE MESSENAS
130	1	MMA 01 490 130	DZC 450-MONTAGE ZAADBAK+ZAADREGELING
140	1	MMA 01 490 140	DZC 450-MONTAGE AANDRIJVING MESSENAS
150	1	MMA 01 490 150	DZC 450-MONTAGE AANDRIJVING TRACTIROL
160	1	MMA 01 490 160	ROULEAU TRACTION
170	1	MMA 01 490 170	DZC 450 MONTAGE EVACUATEUR
180	1	MMA 01 490 180	DZC 450-AANDRIJVING ARCHIMEDESSCHROEF
190	1	MMA 01 490 190	DZC 450 MONTAGE ZAAI-UNIT
200	1	MMA 01 490 200	DZC 450-MONTAGE STUUR
210	1	MMA 01 490 210	DZC 450-OPTIES

MATERIAL_NR		MATERIAL		PROJECT_NR	LENGTH	OVERMAAT
					0.0	
TITLE				NAME	DATE MODIFIED	
DZC 450				koen	2020/05/29	
				NAME	DATE CREATED	
				koen	2020/05/28	
ELIET WWW.ELIET.BE	 Overall Tol ISO 2768-fH	<input checked="" type="checkbox"/> ()	Machine	FORMAT	SCALE	
			D_Z_C 450	A4H	1:10	
ELIET N.V - Zwevegemstraat 136 - B-8553 OTEGEM Tel.: +32/56/77.70.88 - Fax.: +32/56/77.5213		DRW_NR	REVISION	SHEET		
		MMA 01 490 100	1	2 of 2		

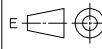
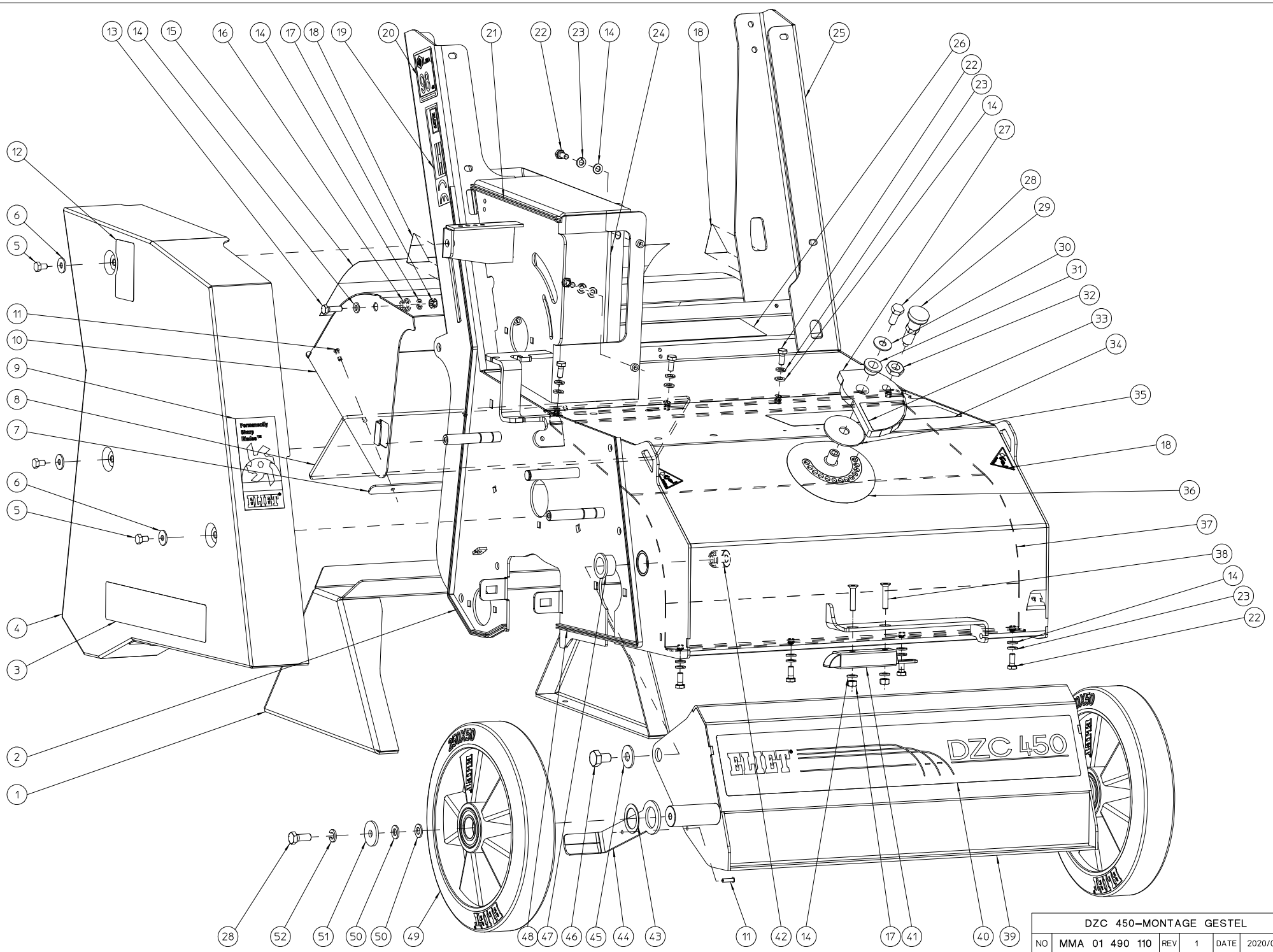

DZC 450-MONTAGE GESTEL					
NO	MMA 01 490 110	REV	1	DATE	2020/05/25

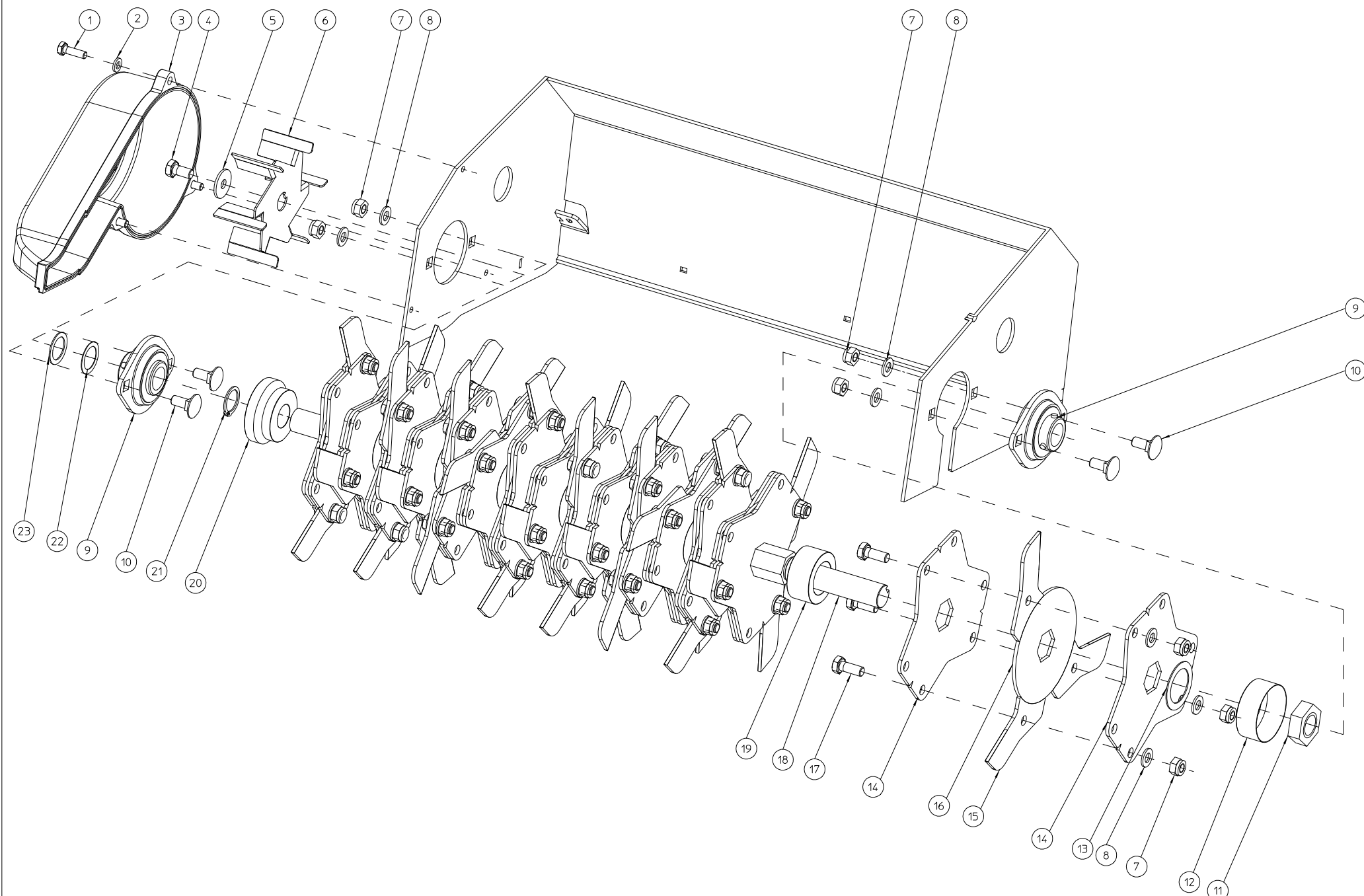

Pos	Qté	Nom	Description
1	1	MPA 01 420 220	SUPPORT NETTOYAGE DZC600
2	1	BR 000 910 650	M U-PROFIEL REF.U1-650
3	1	BQ 501 490 030	KLEVER-ELIET DZC 450 + 2 PICTOGRAMMEN-250X75
4	1	MPA 01 490 140	CAPE DE PROTECTION
5	3	BS 512 000 610	DIN 933 VIS M6X10
6	3	BS 532 006 183	RONDELLE DE CARROSSERIE M6X18X1.5 DIN 440
7	1	MPA 01 490 080	LATTE CAOUTCHOUC DEFLECTEUR ARRIERE
8	1	BR 900 001 900	BAVETTE CAOUTCHOUC DEFLECTEUR DZC450
9	1	BQ 501 010 100	AUTO_SHAPR_BLADES
10	1	MPA 01 490 070	DEFLECTEUR ARRIERE
11	6	BB 221 104 140	BLINDLINKNAGEL 3.9X14 ALU/STAAL
12	1	BQ 505 010 660	KLEVER-WAARSCHUWING NAAR VEILIGHEID 45X70
13	2	BS 512 000 620	DIN 933 VIS M6X20
14	18	BS 531 000 600	DIN 125 RONDELLE M6
15	1	BQ 501 490 020	KLEVER ACHTERAAN- ELIET DZC 450+5 PICTOGRAMMEN
16	2	BR 112 060 800	PALIER + COL. (6/10/15X2+6.5)
17	4	BS 502 000 600	DIN 985 ECRU NYLON M6
18	4	BQ 505 010 560	KLEVER--C550 HAAK
19	1	BQ 505 010 010	AUT.ELIET CE 120X30
20	1	BQ 505 112 098	AUT. DECIBEL 98 DB
21	1	BR 000 910 220	M U-PROFIEL REF.U1-220
22	12	BS 512 000 614	DIN 933 VIS M6X14
23	12	BS 533 000 600	DIN 127 RONDELLE GROER M6
24	1	MPA 01 490 130	CACHE BOITE DE TRANSMISSION
25	1	MPA 01 490 030	CHASSIS
26	1	BQ 501 490 070	KLEVER-ELIET DZC 450-BEDIENINGEN 300X70
27	1	MPA 01 490 100	BUTEE REGLAGE DE HAUTEUR
28	3	BS 512 000 820	DIN 933 VIS M8X20
29	1	BN 000 212 550	BLOKEERSTIFT A-M12X1.5
30	1	BS 532 008 223	RONDELLE DE CARROSSERIE M8X22X1.5
31	1	BR 112 121 090	PALIER + COL. (12/16/22X2+8)
32	1	BS 501 901 202	6 KT MOER M12X1.5-DIN_439B-MF
33	1	BQ 501 490 050	KLEVER ELIET DZC 450 DIEPTE INSTELLING-60X45
34	1	BQ 505 010 650	KLEVER-WAARSCHUWING NAAR VEILIGHEID 230 X 70
35	1	BR 910 001 060	RONDELLE NYLON Ø 50X12,2X2
36	1	BQ 501 490 060	KLEVER ELIET DZC ROSAS-110X100
37	1	MPA 01 490 060	TOLE CARTER
38	2	BS 522 100 630	VERZONKENSCHROEF MET BINNENZESKANT
39	1	MPA 01 490 040	SUPPORT ROUES AVANT
40	1	BQ 501 490 010	KLEVER-ELIET DZC 450 VOORAAN 480X75
41	1	BQ 360 505 180	VEERGRENDEL MET HORIZONTALE TREKPEN-FFM.R.1615.R
42	2	MPA 01 420 105	SCHARNIERAS SCHELP
43	2	BS 036 002 510	RONDELLE D'AJUSTAGE 25X35X1
44	2	MPA 01 420 100	WIELSCHRAPER
45	2	BS 532 010 274	SLUITRING 10,5X27X2
46	2	BS 512 001 016	DIN 933 VIS M10X16
47	2	BR 112 201 500	PALIER + COL. (20/24/30X2+13)
48	1	BR 000 910 450	M U-PROFIEL REF.U1-450
49	2	BW 325 025 000	ROUE ALUMINIUM 250/60-100
50	4	BS 531 000 800	DIN 125 RONDELLE M8
51	2	BS 532 008 306	RONDELLE DE CARROSSERIE M8X30X3
52	2	BS 533 000 800	DIN 127 RONDELLE GROER M8

		PROJECT_NR		
MATERIAL_NR	MATERIAL	LENGTH	OVERMAAT	
		0.0		
TITLE		NAME	DATE MODIFIED	
DZC 450-MONTAGE GESTEL		koen	2020/05/25	
		NAME	DATE CREATED	
		koen	2020/05/25	
 WWW.ELIET.BE	 Overall Tol ISO 2768-fH	 Machine D_Z_C 450	FORMAT A4V	SCALE 1:1
	ELIET N.V. - Zwevegemstraat 136 - B-8553 OTEGEM Tel.: +32/56/77.70.88 - Fax.: +32/56/77.5213	DRW_NR MMA 01 490 110	REVISION 1	SHEET 2 of 2



DZC 450 MONTAGE MESSINAS						
NO	MMA 01 490 120	REV	1	DATE	2020/05/24	

Pos	Qté	Nom	Description
1	3	BS 512 000 620	DIN 933 VIS M6X20
2	3	BS 531 000 600	DIN 125 RONDELLE M6
3	1	BR 930 040 160	ASS. CAGE VENTILATEUR + GRILLE
4	1	BS 512 170 816	TAPBOUT_DIN_933-M8X16-LINKS
5	1	BS 532 008 254	RONDELLE DE CARROSSERIE M8X25X2
6	1	MPA 01 420 135	VENTILATORSCHROEF
7	49	BS 502 000 800	DIN 985 ECROU NYLON M8
8	49	BS 531 000 800	DIN 125 RONDELLE M8
9	2	BL 801 102 002	UCPFL-204
10	4	BS 554 100 820	DIN 603 VIS A BOIS M8X20
11	1	BS 501 902 200	DIN 439 1/2 ECROU M22 1.5
12	1	MPA 01 420 055	STEUNSLUITRING MESSEN-R
13	1	BS 036 003 010	PASRING 30X42X1 MM-DIN 988
14	30	MPA 01 420 265	MESPLAAT
15	45	BU 102 200 300	MES
16	15	MPA 01 420 035	TUSSENRING MES
17	45	BS 512 000 820	DIN 933 VIS M8X20
18	1	MPA 01 490 320	AXE COUTEAUX
19	14	MPA 01 420 060	AFSTANDSRING MESPLAAT.1
20	1	MPA 01 490 330	ENTRETOISE AXE COUTEAUX
21	1	BB 001 000 200	CIRCLIPS EXTERIEUR DIN 471 DIA:20
22	1	BS 036 002 005	TOLERANTIEVLOOT 28X20X0.5
23	1	BS 036 002 010	RONDELLE D'AJUSTAGE 28X20X1

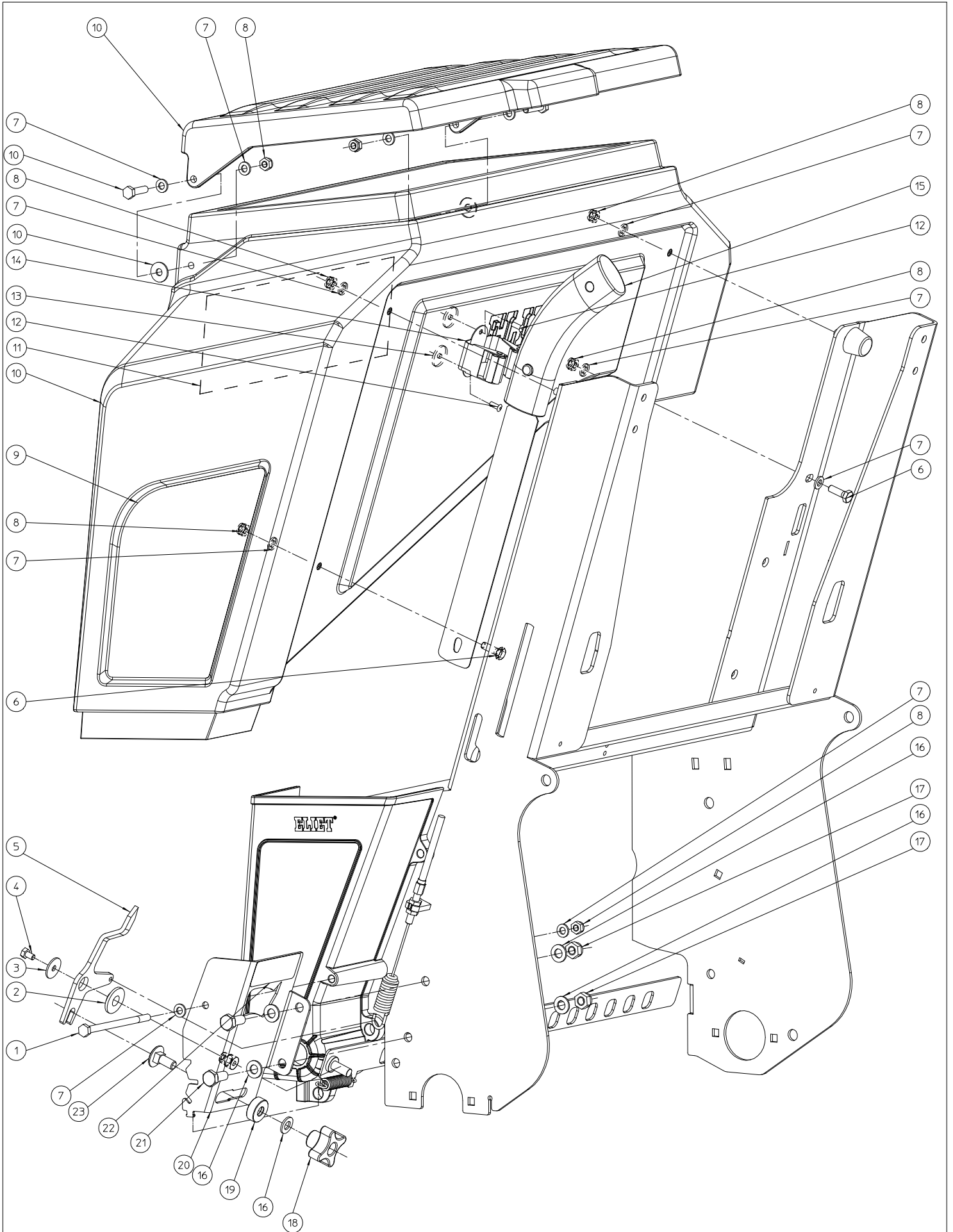

MATERIAL_NR		MATERIAL		PROJECT_NR	LENGTH	OVERMAAT
					0.0	
TITLE				NAME	DATE MODIFIED	
DZC 450 MONTAGE MESSENAS				koen	2020/05/24	
				NAME	DATE CREATED	
				koen	2020/05/23	
 WWW.ELIET.BE	 Overall Tol ISO 2768-fH		Machine	FORMAT	SCALE	
			D_Z_C 450	A4H	1:1	
ELIET N.V - Zwevegemstraat 136 - B-8553 OTEGEM Tel.: +32/56/77.70.88 - Fax.: +32/56/77.5213		DRW_NR	REVISION	SHEET		
		MMA 01 490 120	1	2 of 2		



DZC 450-MONTAGE ZAADBAK+ZAADREGELING

NO	MMA 01 490 130	REV	1	DATE	2020/05/25
----	----------------	-----	---	------	------------

Pos	Qté	Nom	Description
1	1	BS 511 000 650	DIN 931 VIS M6X100
2	1	BR 112 100 600	PALIER + COL. (10/13.5/25X2.5+3.5)
3	1	BS 532 005 202	RONDELLE DE CARROSSERIE M5X20X1
4	1	BS 512 000 508	DIN 933 VIS M5X8
5	1	MPA 01 420 510	SCHARNIERHEFBOOM
6	2	BS 512 000 618	DIN 933 VIS M6X18
7	8	BS 531 000 600	DIN 125 RONDELLE M6
8	5	BS 502 000 600	DIN 985 ECROU NYLON M6
9	1	BQ 501 490 040	KLEVER-ELIET DZC 450-180X185
10	1	BR 930 040 200	ASS. TREMIE DE SEMENCES -- DZC450
11	1	BQ 501 490 080	KLEVER ELIET DZC 450 RENOVA-300X70
12	2	BB 221 004 100	DIN 7337 RIVET ACIER 3.9X10
13	2	BS 532 004 202	CAROSERIESLUITRING M4X20X1,2-ELVZ
14	1	BG 741 905 111	GEREEDSCHAPSHOUDER WIT 22-35MM
15	1	BG 220 225 401	ROLSCHRAPER
16	5	BS 531 000 800	DIN 125 RONDELLE M8
17	2	BS 502 000 800	DIN 985 ECROU NYLON M8
18	1	BN 630 808 400	BOUTON CRANTES OUVERT M8
19	1	MPA 01 420 225	AFSTELRING DOSEERLAT
20	1	MPA 01 420 485	SCHARNIERSTEUN DOSEERPLAAT
21	2	BS 512 000 820	DIN 933 VIS M8X20
22	1	BQ 501 490 090	KLEVER ELIET DZC 450-DEBIET REGELING
23	1	BS 554 100 820	DIN 603 VIS A BOIS M8X20

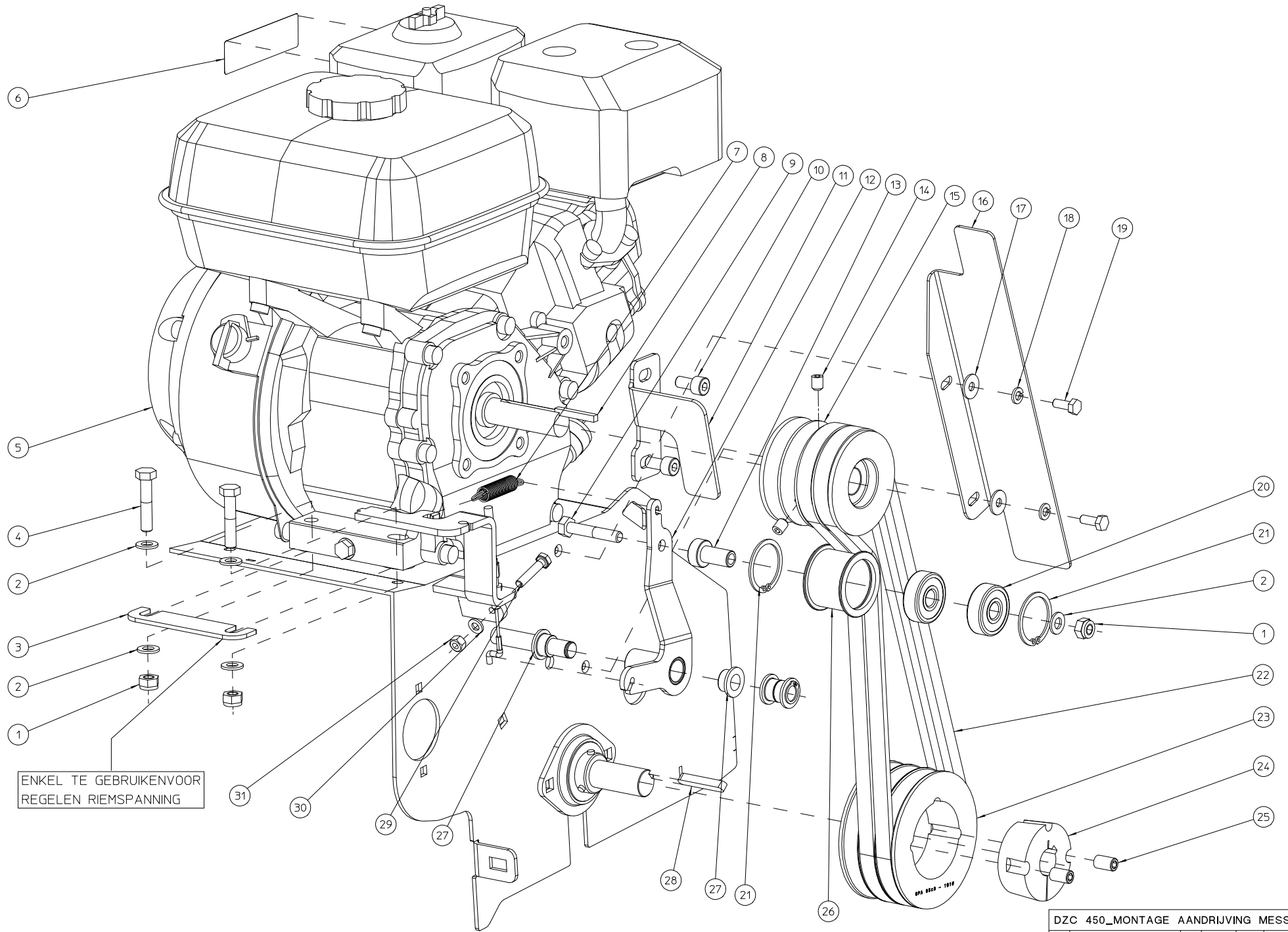

MATERIAL_NNR		MATERIAL		PROJECT_NNR	LENGTH	OVERMAAT
					0.0	
TITLE				NAME	DATE MODIFIED	
DZC 450-MONTAGE ZAADBAK+ZAADREGELING				koen	2020/05/25	
				NAME	DATE CREATED	
				koen	2020/05/25	
 WWW.ELIET.BE	 Overall Tol ISO 2768-fH	<input checked="" type="checkbox"/> () Machine D_Z_C 450	FORMAT	SCALE		
			A4H	1:1		
ELIET N.V. - Zwevegemstraat 136 - B-8553 OTEGEM Tel.: +32/56/77.70.88 - Fax.: +32/56/77.5213		DRW_NNR	REVISION	SHEET		
		MMA 01 490 130	1	2 of 2		



ENKEL TE GEBRUIKENVOR
REGELEN RIEMSPANNING

DZC 450_MONTAGE AANDRIJVING MESSENAS					
NO	MMA 01 490 140	REV	1	DATE	2020/07/02

Pos	Qté	Nom	Description
1	5	BS 502 000 800	DIN 985 ECRou NYLON M8
2	9	BS 531 000 800	DIN 125 RONDELLE M8
3	2	MPA 01 480 180	TUSSENPLAATJE MOTOR
4	4	BS 511 000 840	DIN 931 VIS M8X40
5	1	BM 202 106 500	HONDA GX 200 GX4
6	1	BQ 505 010 030	AUT.MAX 3200T/MIN.I 90X25
7	1	BV 011 011 005	TREKVEER 1X11X55
8	1	BB 342 050 535	DIN 6880 CLAVETTE 4.7X4.7X35
9	1	BS 511 000 841	DIN 931 VIS M8X45
10	2	BS 521 140 816	DIN 912 UMBRACO 5/16" X 5/8"
11	1	MPA 01 490 410	GUIDE COURROIE
12	1	MPA 01 490 350	LEVIER EMBRAYAGE COUTEAUX
13	1	MPA 01 490 360	AXE TENDEUR
14	2	BS 023 000 810	DIN 916 VIS DE PRESSION M8X10
15	1	BA 565 707 141	POULIE SPA 71-4 ALESAGE 3/4" 2X M8
16	1	MPA 01 490 110	GUIDE DE COURROIES
17	2	BS 532 006 183	RONDELLE DE CARROSSERIE M6X18X1.5 DIN 440
18	2	BS 533 000 600	DIN 127 RONDELLE GROER M6
19	2	BS 512 000 616	DIN 933 VIS M6X16
20	2	BL 001 203 703	DIN 625 ROUL.NTN 6301 2RZ
21	2	BB 002 000 370	BORGVEEER DIN-472 Ø37
22	2	BA 527 708 890	V-RIEM SPA ROFLEX GARDEN-4L350-889EXT
23	1	BA 562 709 530	POULIE SPA 95-3 TL1610
24	1	BB 501 132 000	MOYEU AMOVIBLE TL1610_20
25	2	BB 501 310 160	BOULON POUR MOYEU AMOVIBLE-SCR 3/8" X5/8"<--->TL 1210-1610
26	1	MPA 01 350 030	MPA-AANDRUKROL_RIEMSPANNER
27	2	BR 112 121 090	PALIER + COL. (12/16/22X2+8)
28	1	BB 351 060 640	DIN 6885A CLAVETTE ARRONDIE 6X6X40
29	1	BS 512 000 630	DIN 933 VIS M6X30
30	1	BS 531 000 600	DIN 125 RONDELLE M6
31	1	BS 502 000 600	DIN 985 ECRou NYLON M6

MATERIAL_NR		MATERIAL		PROJECT_NR	LENGTH	OVERMAAT
					0.0	
TITLE				NAME	DATE MODIFIED	
DZC 450-MONTAGE AANDRIJVING MESSNAS				dany	2020/07/02	
				NAME	DATE CREATED	
				koen	2020/05/23	
 WWW.ELIET.BE	 Overall Tol ISO 2768-fH	<input checked="" type="checkbox"/> () Machine	D_Z_C 450		FORMAT	SCALE
					A4H	1:1
ELIET N.V - Zwevegemastraat 136 - B-8553 OTEGEM Tel.: +32/56/77.70.88 - Fax.: +32/56/77.5213			DRW_NR	REVISION	SHEET	
			MMA 01 490 140	1	2 of 2	

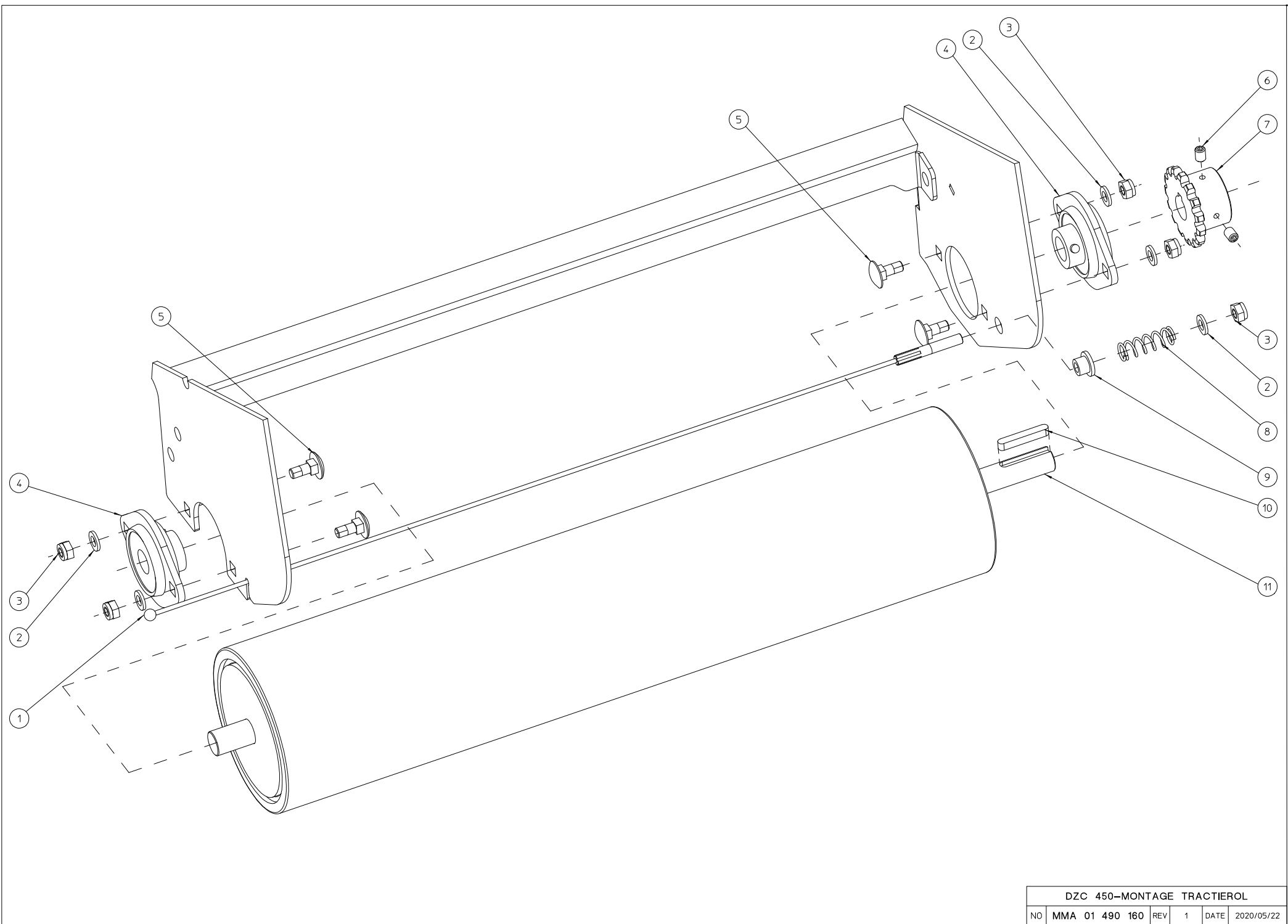

DZC 450-MONTAGE TRACTIEROL						
NO	MMA 01 490 160	REV	1	DATE	2020/05/22	

Pos	Qté	Nom	Description
1	1	BK 155 250 520	CABLE RACLEUR Ø 2,5 X 520 MM
2	5	BS 531 000 600	DIN 125 RONDELLE M6
3	5	BS 502 000 600	DIN 985 ECROU NYLON M6
4	2	BL 801 101 500	PALIER COMPLET ASPFL 202
5	4	BS 554 100 616	DIN 603 VIS A BOIS M6X16
6	2	BS 023 000 608	DIN 916 VIS DE PRESSION M6X8
7	1	BA 171 015 150	KETTINGWIEL 3/8"X7/32" -15T
8	1	BV 925 000 010	DRUKVEER Ø1.3X Ø11X33.6
9	1	BR 112 060 800	PALIER + COL. (6/10/15X2+6.5)
10	1	BB 351 050 532	SPIE DIN-6885-A 5X5X32
11	1	MPA 01 490 050	ROULEAU ARRIERE

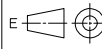
MATERIAL_NR		MATERIAL		PROJECT_NR	LENGTH	OVERMAAT
					0.0	
TITLE				NAME	DATE MODIFIED	
ROULEAU TRACTION				koen	2020/05/22	
				NAME	DATE CREATED	
				koen	2020/05/22	
 WWW.ELIET.BE		Overall Tol	<input checked="" type="checkbox"/> ()	Machine	FORMAT	SCALE
		ISO 2768-fH		D_Z_C 450	A4H	1:1
ELIET N.V - Zwevegemstraat 136 - B-8553 OTEGEM Tel.: +32/56/77.70.88 - Fax.: +32/56/77.5213		DRW_NR	REVISION		SHEET	
		MMA 01 490 160	1		2 of 2	

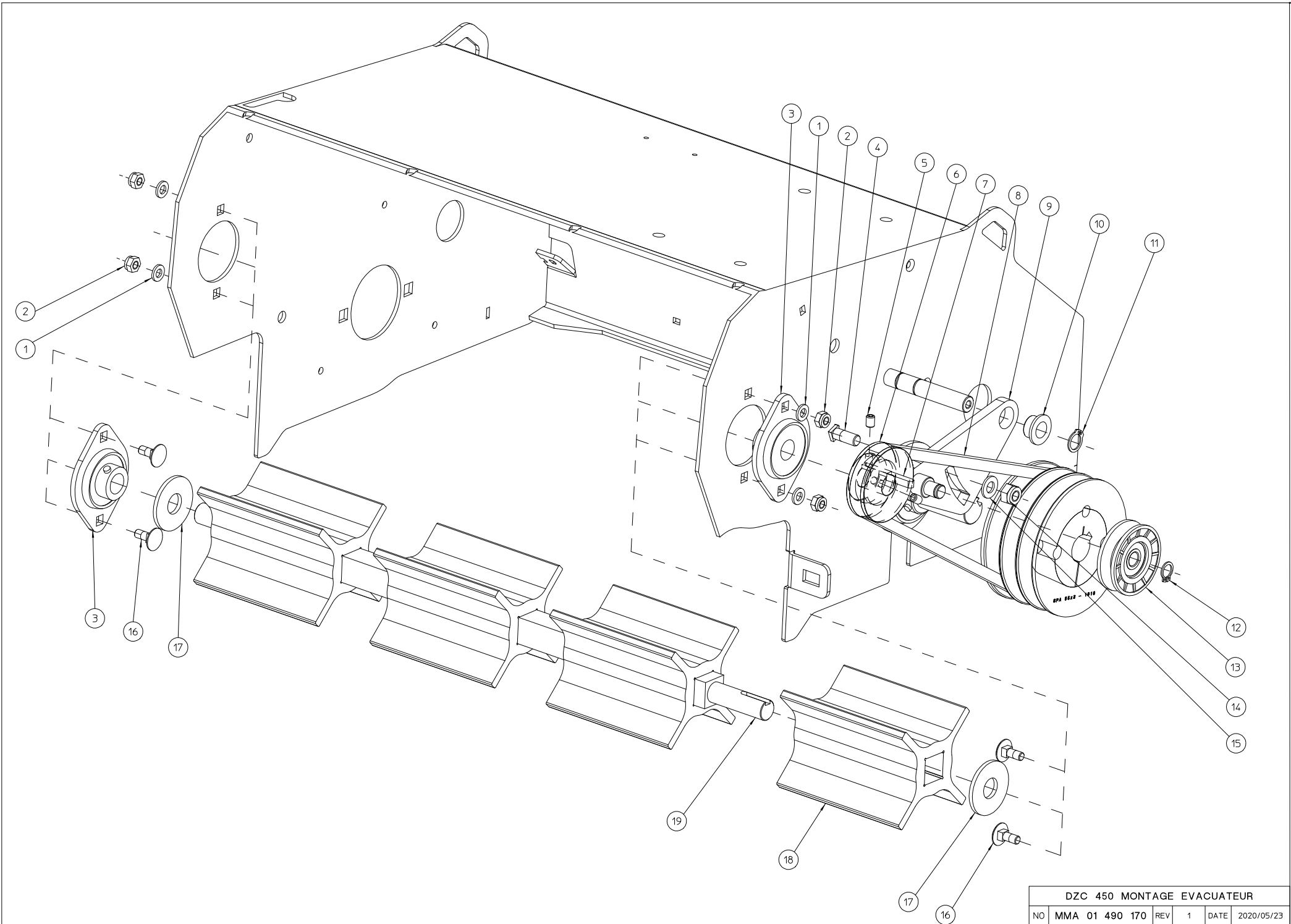

DZC 450 MONTAGE EVACUATEUR						
NO	MMA 01 490 170	REV	1	DATE	2020/05/23	

Pos	Qté	Nom	Description
1	4	BS 531 000 600	DIN 125 RONDELLE M6
2	4	BS 502 000 600	DIN 985 ECROU NYLON M6
4	1	BS 554 100 825	DIN 603 VIS A BOIS M8X25
5	2	BS 023 000 608	DIN 916 VIS DE PRESSION M6X8
6	1	BA 564 705 002	POULIE SPZ 50 ALESAGE 15MM+CLAVETTE 5MM
7	1	BB 351 050 525	SPIE DIN 6885-A 5X5X25
8	1	BA 521 106 300	COURROIE XPZ 630
9	1	MPA 01 490 120	LEVIER TENDEUR DE COURROIE EJECTEUR
10	1	BR 112 121 090	PALIER + COL. (12/16/22X2+8)
11	1	BB 001 000 120	CIRCLIPS EXTERIEUR DIN 471 DIA:12
12	1	BB 001 000 100	CIRCLIPS EXTERIEUR DIN 471 DIA:10
13	1	BA 599 094 350	V-SPANRIEMSCHIJF GM 0138-10128
14	1	BS 502 000 800	DIN 985 ECROU NYLON M8
15	1	BS 531 000 800	DIN 125 RONDELLE M8
16	4	BS 554 100 616	DIN 603 VIS A BOIS M6X16
17	2	MPA 01 490 310	RONDELLE BUTTEE EJECTEUR
18	4	BR 900 001 880	EJECTEUR CAOUTCHOUC Ø 100MM
19	1	MPA 01 490 300	AXE EJECTEUR
3	2	BL 801 101 500	PALIER COMPLET ASPFL 202

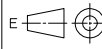
MATERIAL_NNR		MATERIAL		LENGTH	OVERMAAT
				0.0	
TITLE				NAME	DATE MODIFIED
DZC 450 MONTAGE EVACUATEUR				koen	2020/05/23
				NAME	DATE CREATED
				koen	2020/05/22
 WWW.ELIET.BE	 Overall Tol ISO 2768-fH	<input checked="" type="checkbox"/> ()	Machine	FORMAT	SCALE
			D_Z_C 450	A4H	1:1
ELIET N.V. - Zwevegemstraat 136 - B-8553 OTEGEM Tel.: +32/56/77.70.88 - Fax.: +32/56/77.5213		DRW_NR	REVISION	SHEET	
		MMA 01 490 170	1	2 of 2	

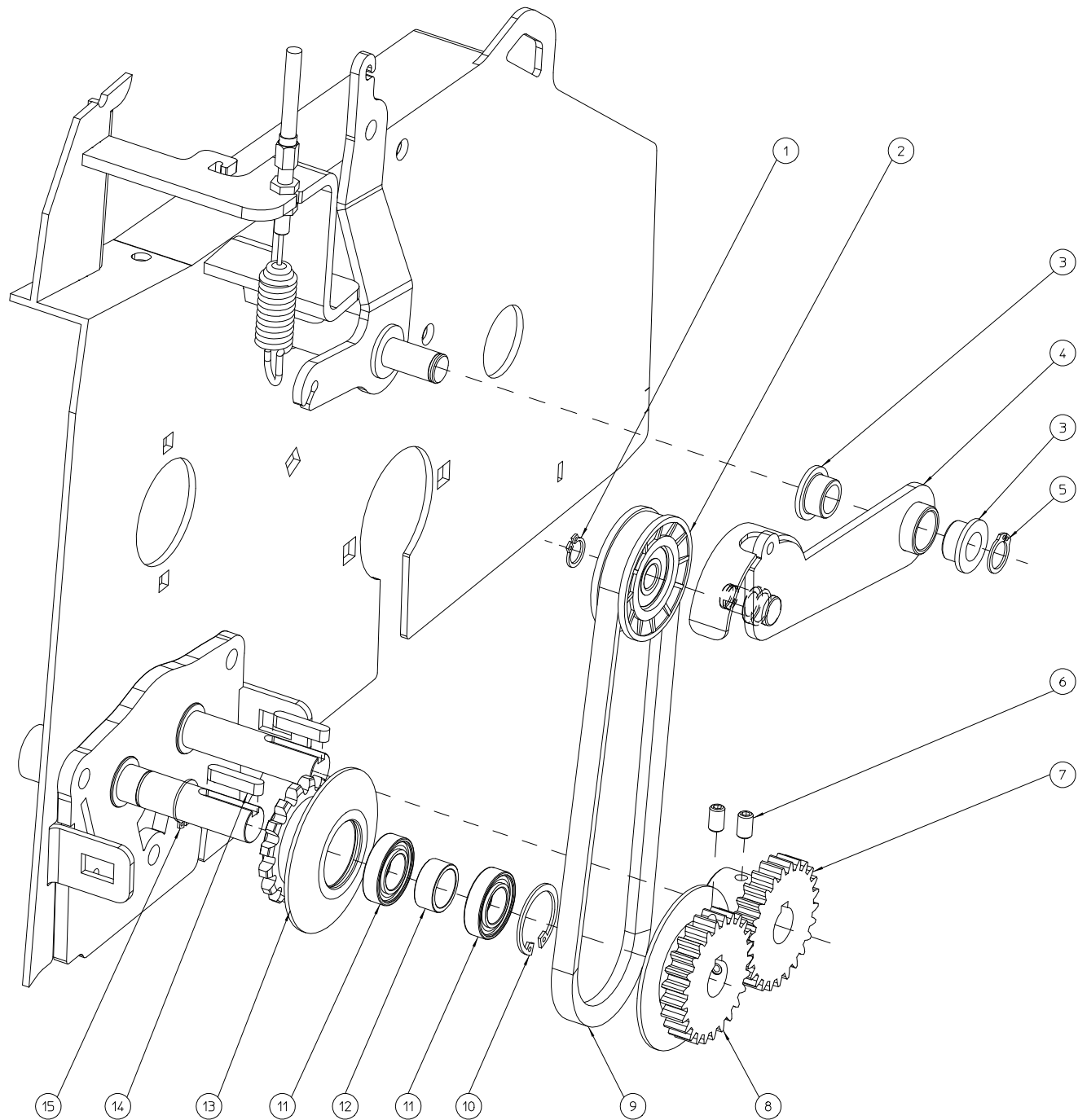

DZC 450-AANDRIJVING ARCHIMEDESSCHROEF					
NO	MMA 01 490 180	REV	1	DATE	2020/05/25

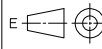

Pos	Qté	Nom	Description
1	1	BB 001 000 100	CIRCLIPS EXTERIEUR DIN 471 DIA:10
2	1	BA 599 094 350	V-SPANRIEMSCHIJF GM 0138-10128
3	2	BR 112 121 090	PALIER + COL. (12/16/22X2+8)
4	1	MPA 01 490 270	LEVIER EMBRAYAGE SEMOIR
5	1	BB 001 000 120	CIRCLIPS EXTERIEUR DIN 471 DIA:12
6	4	BS 023 000 610	DIN 916 VIS DE PRESSION M6X10
7	1	BA 602 002 502	TANDWIEL M2 25T-BORING Ø15+SPIE
8	1	MPA 01 420 320	TANDWIEL-M2 25T+1/2-V-RIEMSCHIJF DM656
9	1	BA 521 104 870	COURROIE XPZ 487
10	1	BB 002 000 280	CIRCLIPS INTERIEUR DIN 472 DIA:28
11	2	BL 001 502 803	LAGER NTN 15X28X7_6902-2RS1
12	1	MPA 01 490 290	ENTRETOISE POULIE TRANSMISSION SEMOIR
13	1	MPA 01 490 280	POULIE TRANSMISSION SEMOIR
14	2	BB 351 050 525	SPIE DIN 6885-A 5X5X25
15	1	BB 001 000 150	CIRCLIPS EXTERIEUR DIN 471 DIA:15

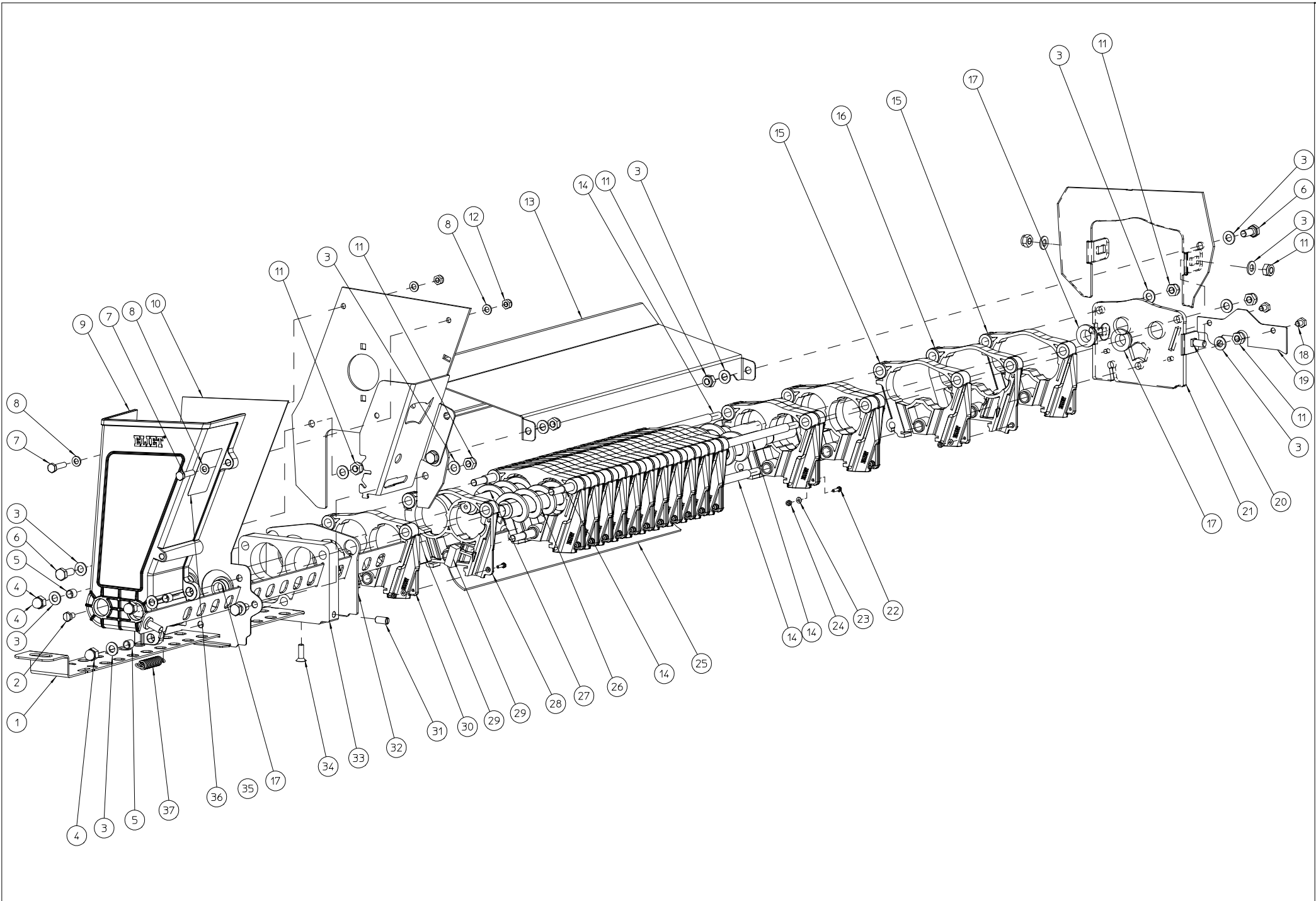
MATERIAL_NR		MATERIAL		LENGTH	OVERMAAT
				0.0	
TITLE			NAME	DATE MODIFIED	
DZC 450-AANDRIJVING ARCHIMEDESSCHROEF			koen	2020/05/25	
			NAME	DATE CREATED	
			koen	2020/05/25	
ELIET WWW.ELIET.BE	 Overall Tol ISO 2768-fH	<input checked="" type="checkbox"/> ()	Machine	FORMAT	SCALE
			D_Z_C 450	A4H	1:1
ELIET N.V. - Zwevegemstraat 136 - B-8553 OTEGEM Tel.: +32/56/77.70.88 - Fax.: +32/56/77.5213		DRW_NR	REVISION	SHEET	
		MMA 01 490 180	1	2 of 2	



DZC 450 MONTAGE ZAAI-UNIT						
NO	MMA 01 490 190	REV	1	DATE	2020/05/28	

Pos	Qté	Nom	Description
1	1	MPA 01 490 230	TOLE VIDANGE SEMOIR
2	1	BS 912 000 610	VISUELE ROTERINGSBOUT DIN 933-M6X10
3	14	BS 531 000 800	DIN 125 RONDELLE M8
4	3	BS 505 500 800	DIN 1587 ECROU TETE RONDE M8
5	3	MPA 01 420 800	AFSTAND BUS
6	3	BS 512 000 820	DIN 933 VIS M8X20
7	2	BS 512 000 625	DIN 933 VIS M6X25
8	4	BS 531 000 600	DIN 125 RONDELLE M6
9	1	BR 930 040 170	ENTONNOIR DE SEMENCES VERSION 2020
10	1	MPA 01 490 200	TOLE CÔTE SUPPORT SEMOIR
11	8	BS 502 000 800	DIN 985 ECROU NYLON M8
12	2	BS 502 000 600	DIN 985 ECROU NYLON M6
13	1	MPA 01 490 090	TÔLE PROTECTION SEMOIR
14	3	MPA 01 490 260	TIGE ENTRETOISE SEMOIR
15	2	BR 930 040 140	ELEMENT GAUCHE BOUT DE SEMOIR (FRAISER)
16	1	BR 930 040 130	ELEMENT DROIT BOUT DE SEMOIR (FRAISER)
17	4	BR 112 151 090	IGIDUUR M250 FLENSGLIJLAGER MFM 1521-10
18	2	BS 512 000 608	DIN 933 VIS M6X8
19	1	MPA 01 490 190	PLAT VERROUILLAGE BAVETTE
20	2	BS 554 100 820	DIN 603 VIS A BOIS M8X20
21	1	MPA 01 490 180	SUPPORT DROIT SEMOIR
22	15	BS 512 000 312	TAPBOUT M3X12 DIN933-ELVZ
23	15	BS 531 000 300	DIN 125 RONDELLE M3
24	15	BS 502 000 300	DIN 985 MOER M3
25	1	BY 431 306 047	PVC STRIP TYPE 1T29 SNAAR Ø5X60X470
26	1	MPA 01 490 240	VIS ALIMENTATION SEMOIR
27	1	MPA 01 490 250	VIS RETOUR SEMOIR
28	14	BR 930 040 110	ELEMENT DE SEMOIR DROIT VERSION 2020
29	2	BR 001 510 103	EPDM CELRUBBER 10X10 LG 25MM
30	14	BR 930 040 120	ELEMENT DE SEMOIR GAUCHE VERSION 2020
31	1	BS 051 600 816	VIS DE PRESSION A RESSORT AVEC BILLE ET FENTE ACIER M8X16
32	1	MPA 01 490 210	TOLE ENTRETOISE SEMOIR
33	1	MPA 01 490 370	ENTRETOISE ELEMENT SEMOIR
34	1	BS 522 100 620	DIN 7991 VIS A TETE FRAISEE M6X20
35	1	MPA 01 490 220	LATTE REGLAGE DEBIT SEMENCES
36	1	BQ 501 251 071	KLEVER ELIET HELIX SEED DUCT-40X60
37	1	BV 925 000 030	TREKVEER Ø1,8XØ13X57-20 WINDINGEN

MATERIAL_NR		MATERIAL		PROJECT_NR	LENGTH	OVERMAAT
					0.0	
TITLE				NAME	DATE MODIFIED	
DZC 450 MONTAGE ZAAI-UNIT				koen	2020/05/28	
				NAME	DATE CREATED	
				koen	2020/05/28	
 WWW.ELIET.BE		Overall Tol	ISO 2768-fH		Machine	D_Z_C 450
		ELIET N.V. - Zwevegemastraat 136 - B-8553 OTEGEM Tel.: +32/56/77.70.88 - Fax.: +32/56/77.5213	DRW_NR		MMA 01 490 190	FORMAT
				REVISION	1	SHEET
						2 of 2

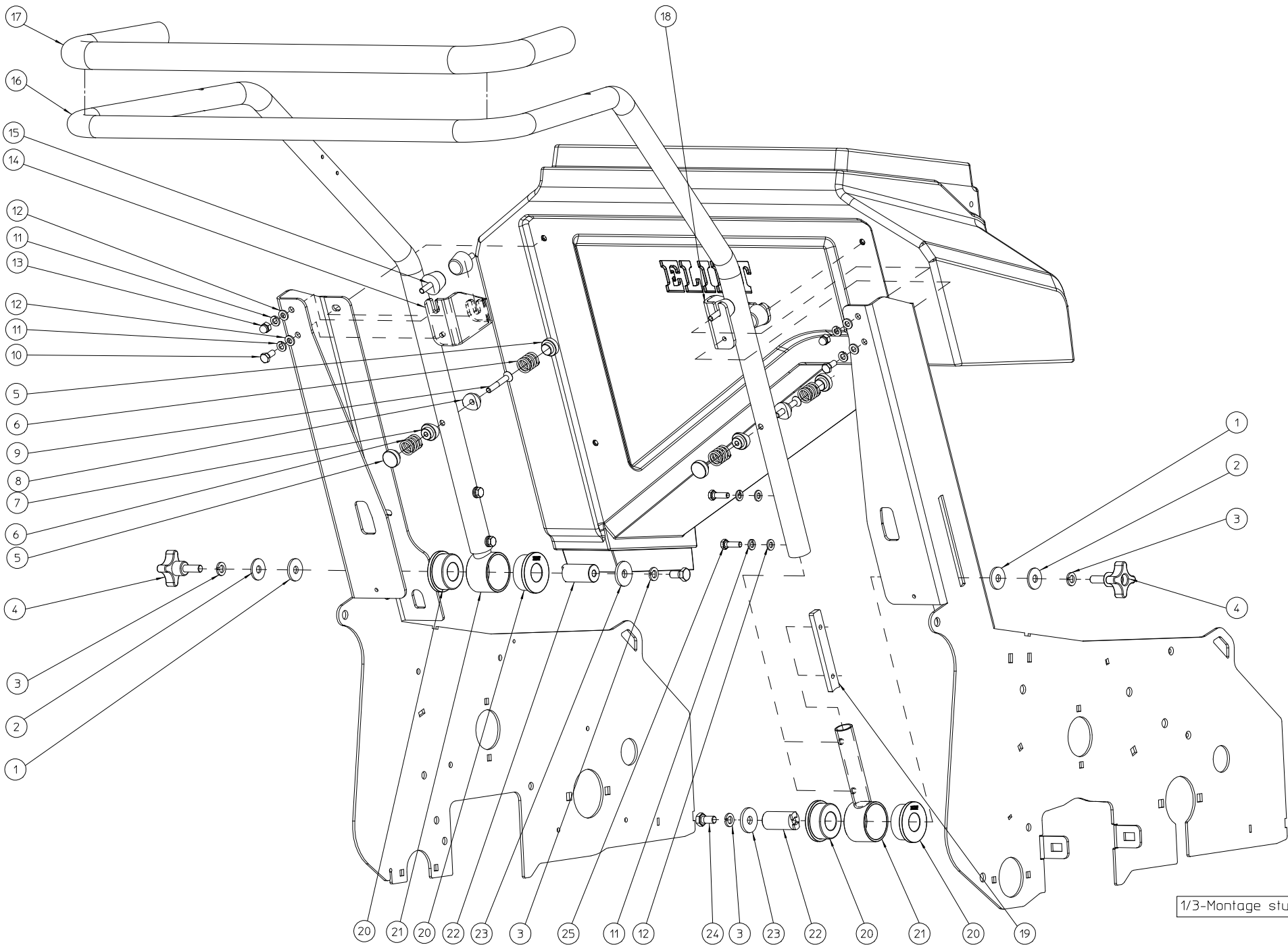

1/3-Montage stuur

DZC 450-MONTAGE STUUR						
NO	MMA 01 490 200	REV	1	DATE	2020/05/27	

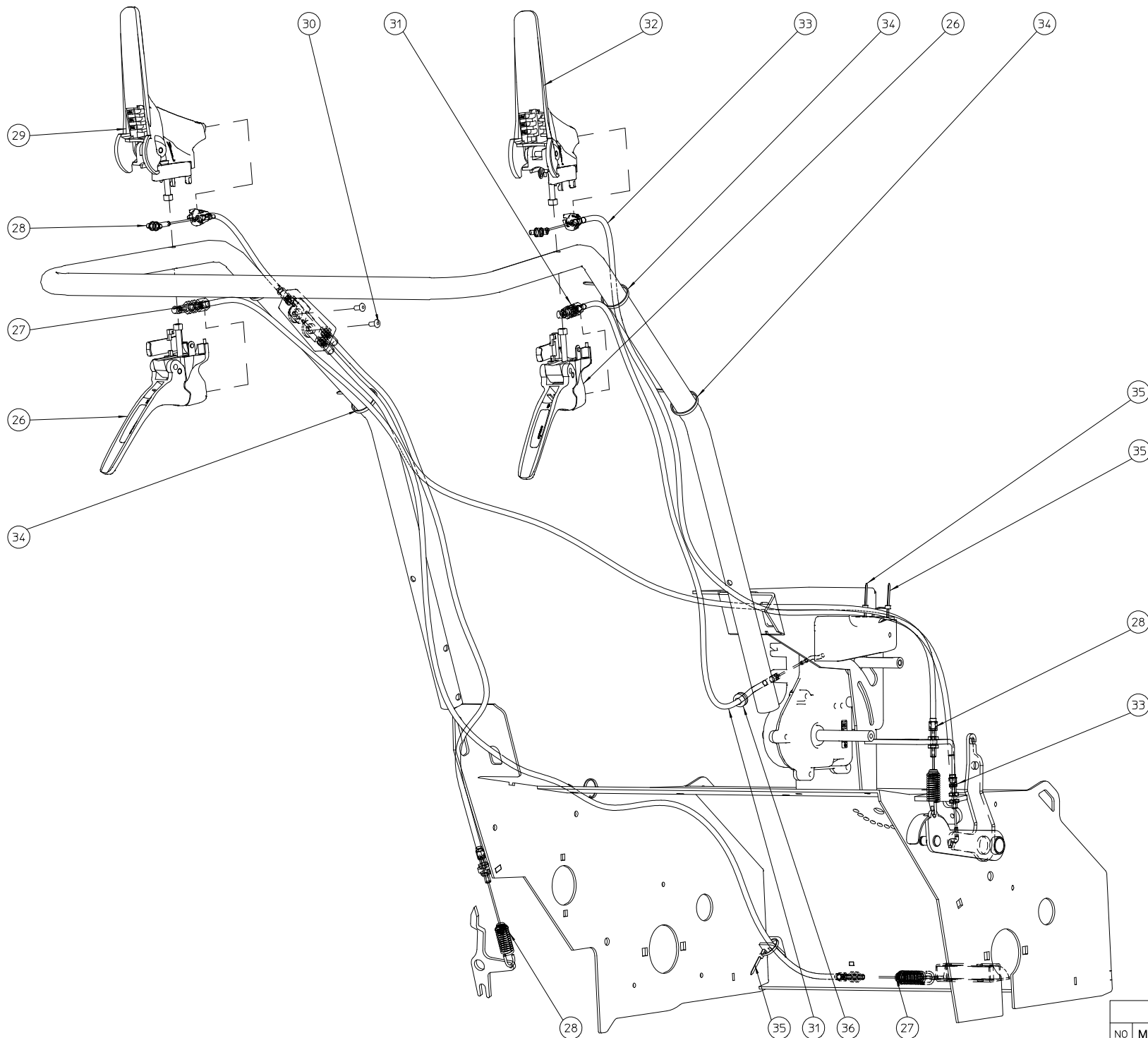



2/3-Montage Stuur

DZC 450-MONTAGE STUUR						
NO	MMA 01 490 200	REV	1	DATE	2020/05/27	

Pos	Qté	Nom	Description
1	2	BR 111 080 200	RONDELLE NYLON 8,4 X 25 X 2,5
2	2	BS 532 008 254	RONDELLE DE CARROSSERIE M8X25X2
3	4	BS 533 000 800	DIN 127 RONDELLE GROER M8
4	2	BN 630 208 200	BOUTON_CRANTES_M8X20
5	4	BR 910 001 090	BUTTEE RESSORT GUIDON
6	4	BV 925 000 040	DRUKVEER 2X17,5X22,5
7	2	BR 910 001 080	BAGUE RESSORT GUIDON (PARTIE FILETEE)
8	2	BR 910 001 070	BAGUE RESSORT GUIDON (PARTIE CONIQUE)
9	2	BS 522 100 640	DIN 7991 VIS A TETE FRAISEE M6X40
10	2	BS 512 000 614	DIN 933 VIS M6X14
11	8	BS 533 000 600	DIN 127 RONDELLE GROER M6
12	8	BS 531 000 600	DIN 125 RONDELLE M6
13	2	BS 505 500 600	DIN 1587 ECROU TETE RONDE M6
14	1	MPA 01 490 390	BUTEE GAUCHE GUIDON
15	4	BR 600 425 170	CYLINDRE BLOC D:25 L:17 M6X18
16	1	MPA 01 490 150	GUIDON
17	1	BN 231 002 090	SOFT_GRIP-SCHLAUG_TP_K_24
18	1	MPA 01 490 380	BUTEE DROITE GUIDON
19	2	MPA 01 480 245	KLEMPLAAT STUUR
20	4	BR 900 001 860	SILENBLOC AMORTISSEUR
21	2	MPA 01 480 165	SCHARNIER KLEMBEUGEL STUUR
22	2	MPA 01 420 875	SCHARNIER KLEMBUS
23	2	BS 532 008 306	RONDELLE DE CARROSSERIE M8X30X3
24	2	BS 512 000 816	DIN 933 VIS M8X16
25	4	BS 512 000 620	DIN 933 VIS M6X20
26	2	BN 332 500 870	HENDEL SACCON LMBC5BB40-MBO-STROKE_DIA.25 BLACK
27	1	BK 156 181 670	CABLE DZC 450 VERROU ROUE AVANT
28	1	BK 156 181 795	CABLE DZC450 SEMOIR+VIS SANS FIN
29	1	BN 332 500 670	BEDIENIGSHENDEL SACCON LMSSY10-MBO-STROKE_27-DIA25 GEEL
30	2	BB 221 005 100	DIN 7337 RIVET ACIER 4.8X10
31	1	BK 156 180 986	CABLE DZC 450 EMBRAYAGE BOITE
32	1	BN 332 500 570	DODEMANSHENDEL SACCON LMSSR10 MBO-STROKE_27-ROOD
33	1	BK 156 181 323	CABLE DZC 450 TENDEUR COURROIE
34	4	BE 043 010 140	COLSON 140 X 3.5 NOIR
35	4	BE 043 010 100	COLSON 100 X 2.5 NOIR
36	1	BR 000 208 030	PASSE-FILS EN CAOUTCHOUC 8/3

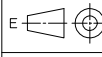
3/3-Montage Stuur

MATERIAL_NR		MATERIAL		PROJECT_NR	LENGTH	OVERMAAT
					0.0	
TITLE				NAME	DATE MODIFIED	
DZC 450-MONTAGE STUUR				koen	2020/05/27	
				NAME	DATE CREATED	
				koen	2020/05/25	
ELIET WWW.ELIET.BE	 Overall Tol ISO 2768-FH	 ()	Machine	FORMAT	SCALE	
			D_Z_C 450	A4H	1:1	
ELIET N.V. - Zwevegemstraat 136 - B-8553 OTEGEM Tel.: +32/56/77.70.88 - Fax.: +32/56/77.5213		DRW_NR	REVISION	SHEET		
		MMA 01 490 200	1	3 of 3		

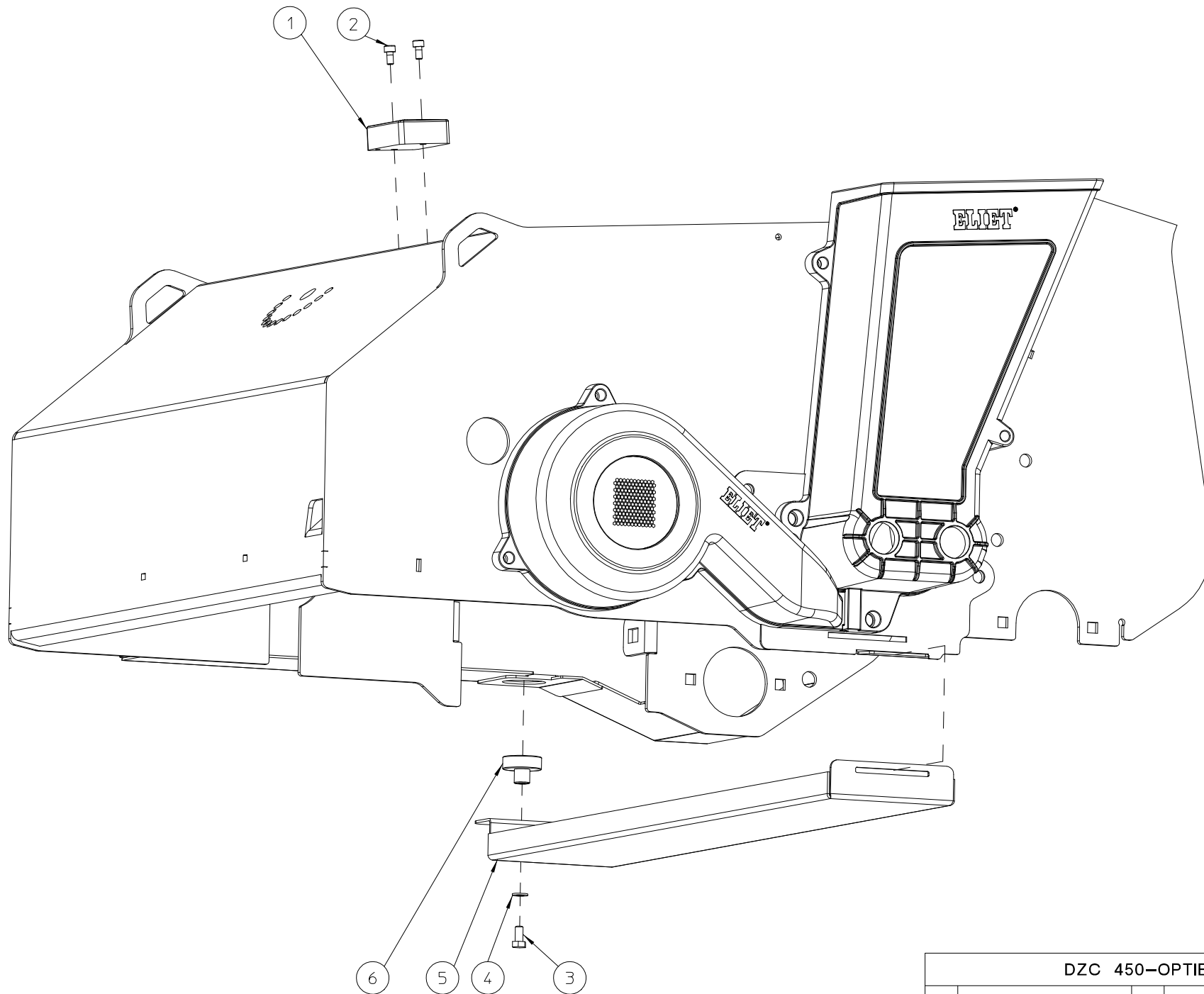

DZC 450-OPTIES

NO	MMA 01 490 210	REV	1	DATE	2020/05/27
----	----------------	-----	---	------	------------

Pos	Qté	Nom	Description
1	1	BE 412 410 001	COMPTEUR-HEURE SENDEC ELIET
2	2	BS 521 100 408	CILINDERKOPSCHROEF MET BINNENZESKANT M4X8-DIN 912
3	1	BS 512 000 510	HEXAGON_HEAD_SCREW_DIN_933-M5X10
4	1	BS 531 000 500	DIN 125 RONDELLE M5
5	1	MPA 01 490 400	BAC MESURE SEMENCE
6	1	BE 120 040 070	RONDE-POTMAGNEET-MET-DRAAD-BUS-M5-DIAM25

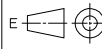
MATERIAL_NBR		MATERIAL		PROJECT_NBR	LENGTH	OVERMAAT
					0.0	
TITLE				NAME	DATE MODIFIED	
DZC 450-OPTIES				koen	2020/05/27	
				NAME	DATE CREATED	
				koen	2020/05/26	
ELIET WWW.ELIET.BE	 Overall Tol ISO 2768-fH	<input checked="" type="checkbox"/> ()	Machine	FORMAT	SCALE	
			D_Z_C 450	A4H	1:1	
ELIET N.V - Zwevegemastraat 136 - B-8553 OTEGEM Tel.: +32/56/77.70.88 - Fax.: +32/56/77.5213		DRW_NBR	REVISION	SHEET		
		MMA 01 490 210	1	2 of 2		