

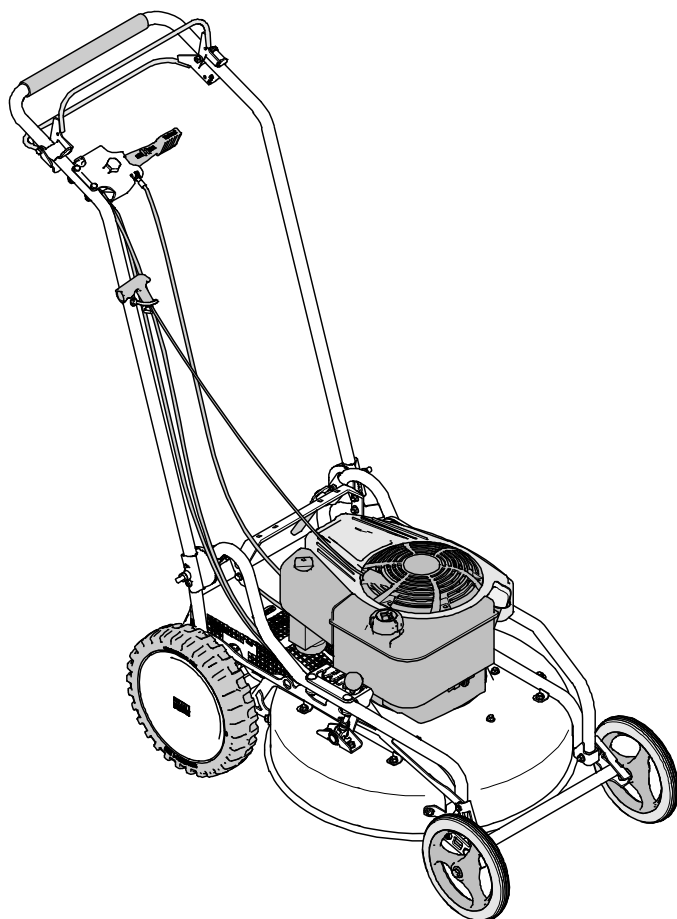

Operating Instructions

Mulching Mower

AS 510 A ProClip



From serial number:

022711030001

Issued:

10 October 2011, V5.0,

EN-Translation of the Original Operating Instructions

Preface

Please fill in all data referring to your device. When ordering spare parts, provide your dealer with the device and engine number.

Serial number:

Engine number:

Date of purchase:

Address of dealer:

Dear customer:

Congratulations on your purchase. You have acquired a reliable quality product by “AS-Motor Germany”.

This product has been manufactured according to modern manufacturing methods and comprehensive quality assurance measures. Only when you are satisfied with your device, we have attained our goal.

Read these operating instructions carefully and attentively so that your device operates smoothly and you and others are safe from any hazards. If you have questions concerning your device, please contact your dealer or call our customer service (telephone +49/(0)7973/9123-0). For international AS partners, please see: www.as-motor.de/worldwide.

“AS-Motor Germany” wishes you much joy with your new device.

Intended use

The device is exclusively intended for mowing well maintained grassed lawn areas.

Only use attachments and cutting tools authorised by “AS-Motor Germany”.

Any use exceeding this purpose is inadmissible. The manufacturer is not responsible for any damage resulting from this. Observe the required maintenance and repair measures.

The user of the device is responsible for accidents or damage to other persons or their property!

The device **must not** be used:

- To cut hard objects, rocks, rubble, or pieces of wood.
- To trim bushes, hedges, and shrubbery.
- To cut plants in flower pots or planters or on rooftops.
- To clean (vacuum) footpaths.
- As shredder for shredding tree and hedge cuttings.
- As drive unit for work tools and any type of tool sets that are not authorised by “AS-Motor Germany”.

Contents

Preface	2	Maintenance and repair	15
Intended use	2	Preparations	17
Explanation of the symbols	4	Cleaning the device.....	17
Symbols in the instructions.....	4	General inspection	17
Symbols on the device	4	Maintaining the engine	17
Safety instructions	5	Checking the engine oil level	17
Get informed!.....	5	Checking the spark plug.....	18
User restrictions and hours of operation ...	5	Cleaning the air filter	18
Safe handling of fuel.....	5	Checking the drive.....	18
Check the device prior to use	5	Checking the blade.....	18
Use caution during operation	6	Storage	19
Prior to mowing.....	6	Storing the device.....	19
Use caution when mowing	6	Longer storage	19
When work is completed	7	Restarting	20
Use caution during maintenance and repair	7	Spare parts	20
Device description	9	Wear parts	20
Control elements	10	Accessories	20
Assembly	10	Disposal	20
Scope of delivery.....	10	Warranty	20
Unpacking.....	10	Troubleshooting	21
Mounting guide bar and handlebar.....	11	Technical data	24
Inserting starter rope	11	Declaration of conformity	25
Transport	11		
Information on mowing	12		
Prior to starting	12		
Fuel.....	12		
Tanking up.....	12		
Checking the engine oil level.....	12		
Adjusting cutting height	13		
Starting	13		
Starting the device.....	13		
Driving	13		
Driving	13		
Turning	14		
Switching off and parking	14		

Explanation of the symbols

Symbols in the instructions

In these operating instructions, the following symbols are used to denote special dangers.



Warning.
These symbols denote special dangers.



Prohibition sign.
These symbols denote inadmissible procedures.



Directive sign.
These symbols denote required protective measures.

Symbols on the device

The following symbols are placed on the device to inform you must be careful and attentive when using the device:

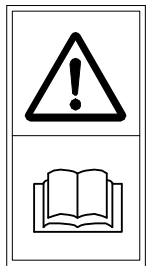

Working with the device requires extreme cautiousness. Read the operating instructions before you use the device.



Risk of injury!
Make sure that no one is within the danger zone of the device. Objects may be ejected. The danger zone extends for at least 15 metres.

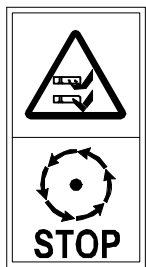

The quickly rotating blade can cause life threatening injuries or immense property damage! Be especially careful to keep your hands and feet away from the blade when the device is put into operation.

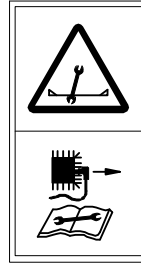

Prior to any repair and maintenance work, pull off the spark plug connector.



Clean the ventilation grid! The cooling air of the motor is sucked in through the ventilation grid of the engine cover. Always keep the entire surface open and free!



Noise is causing health problems. Use personal ear protection to avoid hearing damage.

Type plate

The type plate on the device provides you with information on the device type and the technical data.

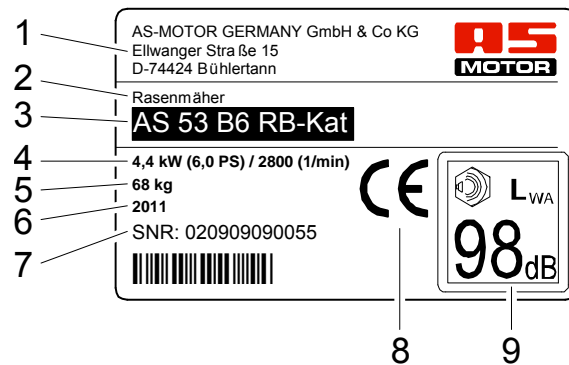

- 1 Name and address of the manufacturer
- 2 Device designation
- 3 Type designation
- 4 Rated power output in kW / engine speed
- 5 Weight
- 6 Year of manufacture
- 7 Serial number
- 8 CE marking
- 9 Sound level L_{WA}

Safety instructions

Get informed!

For your safety, read these operating instructions with care. Familiarize yourself with the control elements and the proper use of the device. Share these operating instructions with other users of the device.

Before you use the device for the first time, let the dealer instruct you regarding safe use.

User restrictions and hours of operation

Never give your children or other persons who are not familiar with the operation instructions permission to use the device. Persons under 18 years old may operate the device only under supervision. Local regulations will determine the minimum age of the user and the hours of operation.

Unsuitable for the operation of the device are persons

- Who are under the influence of alcohol, drugs, or medicine that slows down reaction time.
- With physical and mental impairments.



People fitted with pace makers are not allowed to touch any current carrying parts of the ignition system.

Safe handling of fuel



Danger!

Fuel is toxic and highly flammable.



Danger of fire and explosion!
Keep the fuel away from ignition sources and do not smoke while handling the device.

Do not inhale fuel vapours; they are dangerous to your health.



Use gloves and avoid skin contact with the fuel.

Fuel up outdoors only when the engine is cool and not running. Use a filler or funnel.

Do not spill any fuel and do not let the fuel get into the canalisation or ground water.

If you spilled fuel, do not start the device until the fuel vapours have evaporated (wipe dry). Move the device away from the area where the fuel was spilled.

Always close the tank cap securely and do not open it while the engine is running or the device is still hot.

Drain the fuel tank only when outdoors. Use a suitable container or run the tank empty.

Keep the fuel away from children and store it in a suitable container in a dark, cool, and dry location.

Never park the device with fuel in the tank inside a building where fuel vapours could come in contact with open fire or sparks.

Immediately replace a damaged fuel tank or tank cap (authorised dealership).

First aid

When swallowing fuel or inhaling fuel vapours, do not force vomiting and immediately consult a doctor.

In case of skin contact, immediately wash with water and soap. Change your soiled clothing as soon as you can.

Measures in case of a fire

In case of a fire, use foam, dry powder extinguisher, or carbon dioxide (CO₂). Never douse with water!

Check the device prior to use

Prior to use, check by visual inspection blade, drive and fastening parts for proper condition and firm seating.

Never use the device if covers are defective.

Do not remove, change or override any safety devices or control elements.

Observe the maintenance instructions and replace damaged or worn parts immediately.

Have an authorised service centre check your device if the blade does not stop within 3 seconds after switching off.

Use caution during operation

Do not start the engine:

- if fuel was spilled.
- in closed or poorly ventilated rooms (danger of poisoning!).
- if there are other persons nearby.

Only start the device when your feet are at a safe distance to the blade.

During startup of the engine, do not tilt the device.

Do not touch the engine or the silencer. They become very hot during operation and you can get burned. Resulting unintentional movements constitute an additional injury hazard.

Switch off the engine and wait until the blade comes to a standstill

- before you tilt or transport the device.
- if you step away from the device, even for just a short time.
- if you move over surfaces other than grass.
- before you adjust the cutting height.
- before you refuel.

Switch off the engine, wait until the blade comes to a standstill, and pull off the spark plug connector

- before you clean or check the device or before you carry out work on the device.
- before you unblock or unclog the discharge area.

Prior to mowing

Personal protective measures



While mowing, always wear sturdy footwear with good grip, long trousers, and gloves. Do not mow in open sandals or bare feet.



Noise is causing health problems. Use personal ear protection to avoid hearing damage. Wear safety glasses and headgear.

Preparing the mowing area

Prior to mowing, carefully check the perimeter of the lawn. Remove rocks, pieces of wood, bones, wires, and other objects that could be picked up and thrown out by the device.

Use caution when mowing

Risk of injury

Always stay within hearing range to other persons who can assist you in case of an emergency.



Danger!

Risk of injury caused by thrown out objects.

Never mow while persons, children, pets, or property are in the vicinity.



The danger zone extends for at least 15 metres.

The area in front of and to the right of the device is especially dangerous.

Keep your hands and feet away from rotating parts.

Mow only in daylight or good artificial light.

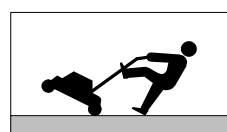

Avoid mowing wet grass - slipping hazard.

Be extremely cautious when turning the device round or pulling it toward you and when moving in reverse.

Always walk slowly!

Never lift or carry the device when the engine is running.

When using the device over a longer period of time, vibrations can cause disturbances in the blood supply of the hands. A generally accepted usage time cannot be determined. Use gloves.

Take breaks on time.

Have an authorised service centre check the device immediately

- if the blade hit an object.
- if the device starts to vibrate unusually severely.

Caution when mowing slopes

Devices fitted with a four stroke engines may only be operated on less than 20° slopes. Otherwise, the four stroke engine can be damaged due to insufficient oil lubrication.



When mowing slopes, there is a risk of slipping and tilting!

- Only mow steep slopes when safe operation assured.
- Do not mow excessively steep slopes.
- When mowing steep slopes, meet the appropriate safety measures, e.g. use step irons.
- Always mow in horizontal directions, never up- or downwards.
- Sure footing is essential for your safety, always wear skid proof safety shoes.
- Be extremely careful when changing the direction.
- Only mow when the surface is dry and non-slip.

The device can roll away when you mow downhill. Put the device down on even surfaces only and prevent inadvertent rolling.

Mowing surfaces with fire hazard

- Carry a sufficient amount of suitable extinguishing agent.
- If side inclination is too great, fuel may leak from the carburetor or the tank. This poses a fire hazard!
- Observe the mowed surface also after moving is completed to ensure that no fire will start.

To avoid risk of fire, keep the following components free of dirt, grass, hay, leaking oil, grease, etc.:

- Engine
- Silencer (manifold, guard, clearances)
- Area around the fuel tank

When work is completed

After each mowing, close the fuel valve.

Prior to leaving the device, wait until the blade comes to a standstill and pull off the spark plug connector.

After switching it off, let the device cool down for at least 20 minutes before you store it in a dry, closed, sufficiently ventilated room.

Never store the device when there is fuel in the tank inside a building where fuel vapours might come into contact with open fire or sparks.

Use caution during maintenance and repair

Only carry out maintenance work as described in these operating instructions. Have an authorised service centre carry out all other work.

Prior to starting any maintenance work, wait until the engine comes to a standstill and pull off the spark plug connector.

We explicitly point out that, in accordance with the Product Liability Act, we are not liable for damages that were caused by our devices if

- worn or damaged parts were not repaired or replaced on time
- these damages were caused by improper repair.
- when changing a part, our original parts or parts authorised by use were not used.
- the repair work was not carried out by an authorised service station.

The same applies for spare parts and accessories.

Device description

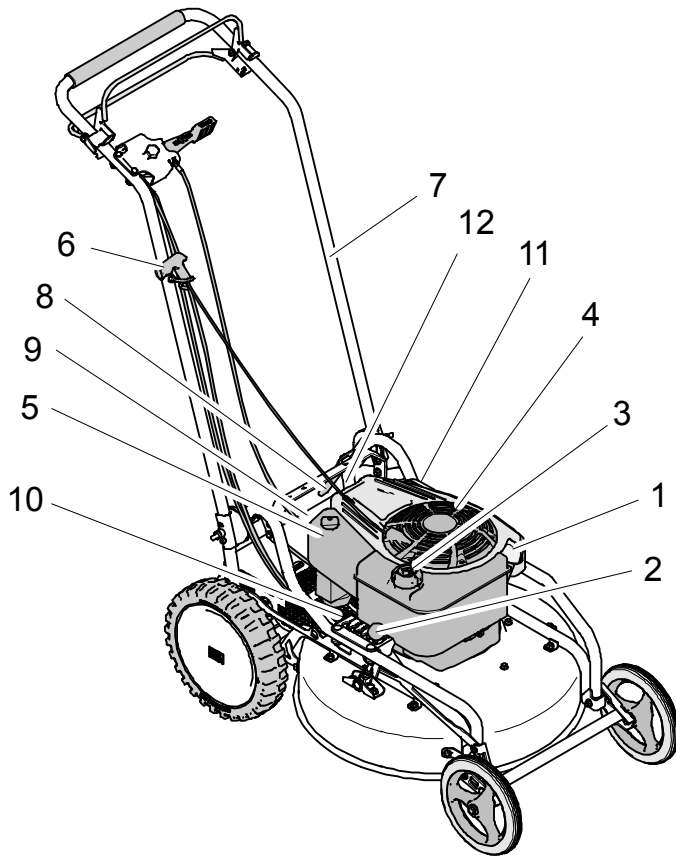

- | | | | |
|----|--|----|----------------------|
| 1 | Oil filler opening | 11 | Silencer |
| 2 | Cutting height adjustment (40 mm, 50 mm, 60 mm, 70 mm, 80 mm, 90 mm) | 12 | Spark plug connector |
| 3 | Tank filler spout | | |
| 4 | Ventilation grid | | |
| 5 | Air filter | | |
| 6 | Starter grip | | |
| 7 | Handlebar with control elements | | |
| 8 | Eccentric tension lever for fastening the bar | | |
| 9 | Type plate | | |
| 10 | Fuel valve | | |

Control elements

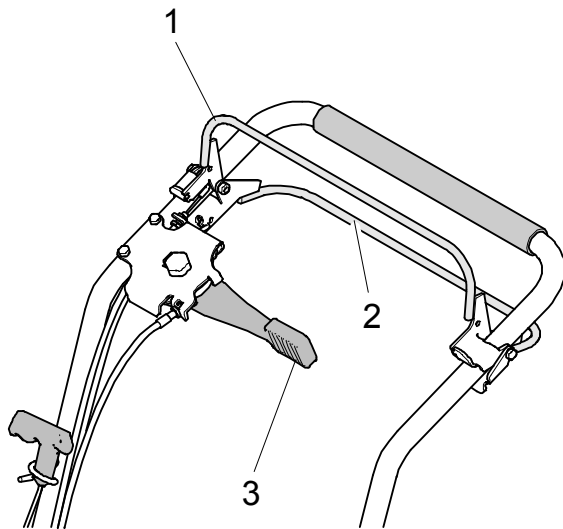

Engine brake bar (1)

The engine brake bar is a protective device. When you release the bar, the engine shuts down immediately, the blade comes to a standstill within 3 seconds.

Operating position:

Press the engine brake lever toward the handlebar.

Turning off the engine:

Release the engine brake bar.

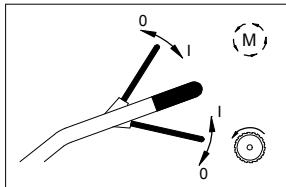

Top:
Engine brake bar

Bottom:
Drive bar

Drive bar (2)

With the drive bar, you switch the drive on and off.

Drive on:

Pull the bar toward the handlebar.

Drive off:

Release the bar.

Vario lever (3)

With the vario lever, you can continuously adjust the speed of the device while the engine is running.

MIN: = slow

MAX: = fast

Fuel valve

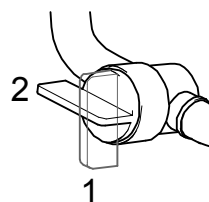

1: Closed

2: Open

Assembly

Scope of delivery

The device is delivered in a carton.

The scope of delivery includes:

- The device.
- These operating instructions.
- Tool bag with small items.
- Warranty card.
- Operating instructions of the engine manufacturer.

Unpacking

1. Remove the loose parts from the box.
2. Cut open the front side of the box.
3. Push the device out of the box.

Mounting guide bar and handlebar

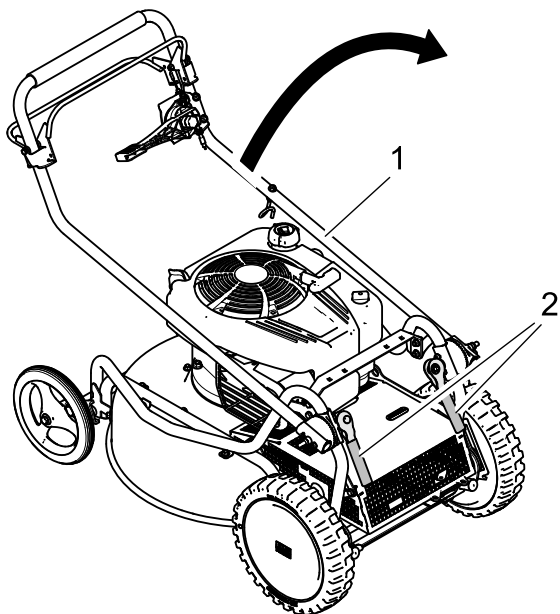

1. Move the guide bar (1) backwards.
2. Adjust the guide bar to the desired height and tighten with the two eccentric tension levers (2).

Inserting starter rope

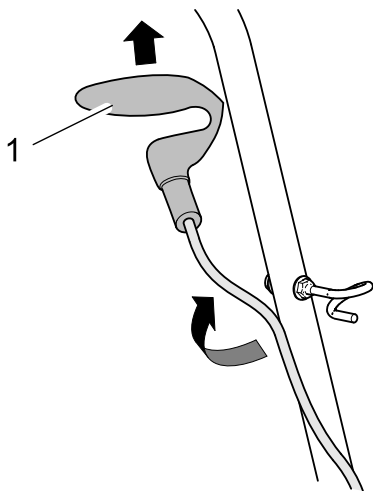

1. Press and continue to hold the engine brake bar.
2. Slowly pull the starter rope at the starter grip (1) and insert it into the guide.

Transport

Switch off the engine and wait until the blade comes to a stop before you lift the device. It takes two persons to safely lift the device.

Prior to transport, let the device cool down for at least 20 minutes. Close the fuel valve.

For transport, you can fold up the guide bar.

When transporting by vehicle, secure the device against rolling, sliding, tilting, and fuel and oil leakage.

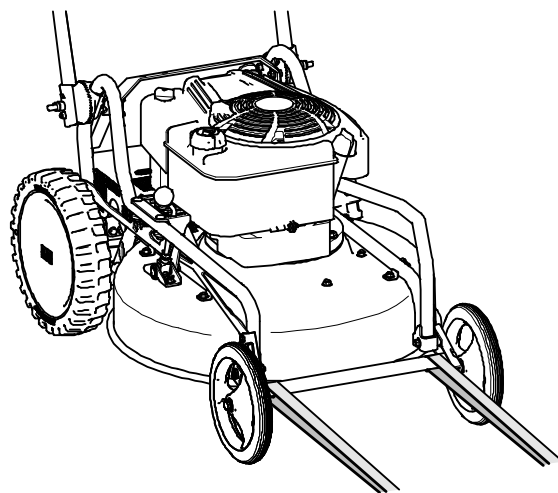
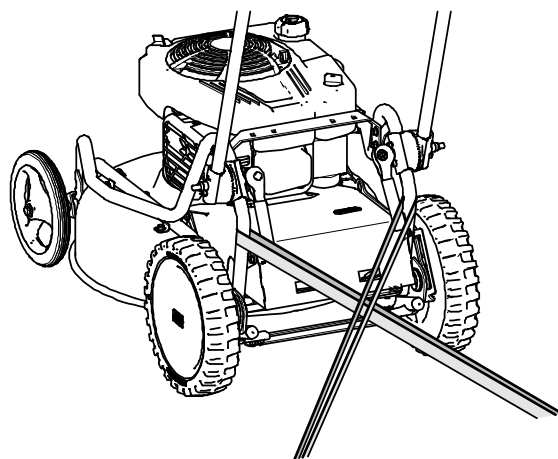

Use tension belts to secure the device.

Beware! To avoid damage to the device, fasten the tension belts exclusively as shown in the illustration.

Information on mowing

Prior to mowing, check your device for completeness, proper functioning, and cleanliness. A dirty ventilation grid can damage the engine and a dirty protective grid at the silencer poses a fire hazard.

To keep the area well maintained, mow frequently and keep the grass short. Do not mow your lawn too low in dry and hot conditions because the lawn is susceptible to sun and heat damage and will look unsightly!

Only mow with a sharp and undamaged blade so that the blades of grass do not fray. Have the blade sharpened and balanced regularly (authorised service centre).

Do not mow when the grass is wet or when it is raining. The turf may be damaged and there is a danger of slipping!

Turn the device around only in already mown sections. Do not leave the device unattended while the engine is running.

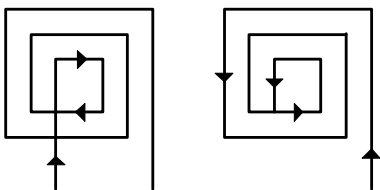

To evenly distribute grass remains and to achieve an even cutting height, we recommend, for flat terrain, to proceed according to the illustrated mowing pattern.

The mulch layer that results from mowing should not be thicker than 1 - 2 cm. Otherwise, during the decomposing process, a thick layer forms that negatively affects the important air-gas-exchange of the soil. In addition, the mower can clog.

If you mow once a week or every other week, we recommend a cutting height of 7 - 8 cm. If you desire a lawn that is lower, you need to mow more often. As a rule, you should not be cutting off more than 1/3 the length of blade of grass.

If the grass is extremely high, mow twice at different cutting height settings.

Prior to starting

Fuel

As fuel, use unleaded petrol (see operating instructions of the engine manufacturer).

Tanking up



Danger!

Fuel is ignited by hot engine parts. Prior to filling up, switch off the engine and wait for at least 20 minutes until the engine has cooled down. Observe the safety instructions regarding the fuel!

Filling in the fuel:

1. For filling, use a canister with a filler spout or use as funnel.
2. Open the canister carefully so that the existing overpressure is discharged slowly and no fuel spurts out.
3. Open the tank cap carefully so that the existing overpressure is discharged slowly and no fuel spurts out.
4. Fill the fuel tank.
5. Screw the tank cap on tightly.

Checking the engine oil level

Attention! Prior to each use, check the engine oil level (see operating instructions of the engine manufacturer).

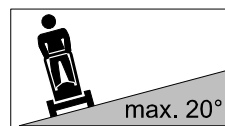

To ensure sufficient oil supply for the four stroke engine and to avoid resulting engine damage, the device may only be used on slopes up to 20°.

Adjusting cutting height

Adjust the cutting height setting only when the engine is switched off.

Set the cutting height so that the blade does not touch the ground even in case of terrain unevenness. If the cutting height is set too high, objects can be ejected and the “clean cut appearance” can be destroyed.

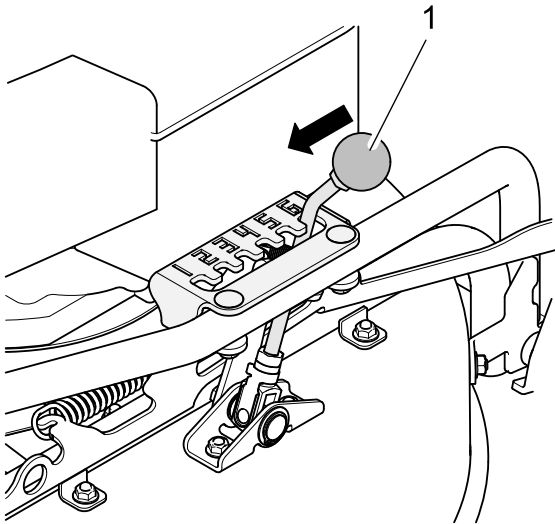

1. Switch off the engine and wait until the blade has come to a standstill.
2. With the central adjustable lever (1) adjust the cutting height. The cutting height can be adjusted in 6 levels from 4 cm to 9 cm.

Starting



Danger!

During startup, there is a risk of injury caused by the rotating blade. Make sure that no one is within the danger zone of the blade. Do not tip the device over to one side during startup.



Danger!

If after startup the carburetor does not close properly, fuel will overflow and a fire hazard occurs. Close the fuel valve and contact an authorised service centre.

Starting the device

1. Place the device onto a flat surface, not in high grass.
2. Open the fuel valve.
3. Plug on the spark plug connector.
4. Actuate and continue to hold the engine brake bar.
5. Pull the starter point slowly out until you feel resistance then pull out quickly – engine starts to run.
6. Let the starter rope retract slowly.

Driving



Danger!

Risk of injury caused by tripping or sliding while moving the mower backwards and turning it round. Make sure that the area is clear of objects and watch for safe footing.

Driving

In case of a dangerous situation, switch off the blade by releasing the engine brake bar.

Drive on:

1. Switch the vario lever for the speed to "MIN".
2. Pull the drive bar towards the handlebar - device is running.
3. With the vario lever, adjust to the desired speed

Drive off:

1. Release the drive bar.

Adjusting speed:

The driving speed can be continuously adjusted with the vario lever.

Adjust the driving speed only when the engine is running.

Turning

Turn the device round only where the grass has been mowed already.

Turning round on an even surface:

1. Switch off the drive.
2. Turn the device to the desired side.
3. Switch the drive back on.

Turning round on a sloping area:

1. Keep the drive switched on.
2. Turn the device upslope.
3. Hold back the handlebar and the inner wheel.

The drive prevents sliding and supports the turn manoeuvre.

Switching off and parking



Caution!

On a slope, the device can roll away.

Put the device on even ground only or secure it against rolling away.

1. Release the drive bar.
2. Release the engine brake bar.
3. Wait until the blade comes to a standstill before you step away from the device.
4. Close the fuel valve.
5. Pull off the plug connector.

Maintenance and repair

Regular maintenance keeps your device ready for use.

If you do not observe the maintenance notices, faults may occur that are not covered

by the warranty. Operational safety is endangered as well.

Contact your authorised service centre for checkup if you detect problems during maintenance.

Component	Action	Maintenance interval	
		Before and after each use	Annually or every 50 h
Device	Check for safe working condition.	■	▲
	Clean.	■	
	Customer service.		▲
Fuel	Check fuel level.	■	
	Is the tank cap closed?	■	
Tank, fuel valve, and fuel line	Check parts for leaks and check for good condition.	■	▲
Carburetor	Does the carburetor close again after starting?	■	▲
Ventilation grid	Clean.	■	▲
Engine cooling	Clean.		▲
Spark plug	Check/adjust.	■	
	Replace.		■▲
Air filter	Check/clean.	■	▲
	Replace.		■▲
Blade and fastening components	Check for wear and damage. See chapter Checking the blade.	■	▲
	Change.		▲
Engine brake	Does the blade stop within 3 seconds?	□	▲
Drive lever	Does the device stop when the lever is in zero position?	□	▲
V-belt	Are the V-belts tensioned correctly, without fissures, and in good condition?		▲
Bowden cables	Check for proper function and ease of movement.	■	▲

Component	Action	Maintenance interval	
		Before and after each use	Annually or every 50 h
Chassis and impact protection	Check for rust and fissures and check the welding seams.	■	▲
	Are all protective device fastened correctly and properly functioning?	■	▲
Label	Condition of the labels.	■	▲
Engine	See operating instructions of the engine manufacturer.	■	▲
	Check oil level (see operating instructions of the engine).	■	▲
	Oil change.		▲
Flammable material	Remove easily flammable debris buildup from the engine and the device.	■	▲
Tires	Check tires and tire pressure if necessary.	■	▲

- By the user when the engine is not running.
- By the user when the engine is running.
- ▲ By the authorised service centre.

Preparations

Prior to all maintenance and cleaning work:

1. Let the device cool down for at least 20 minutes.
2. Pull off the spark plug connector.
3. Close the fuel valve.
4. For work on the bottom of the device, tilt the device to the silencer side.

Cleaning the device

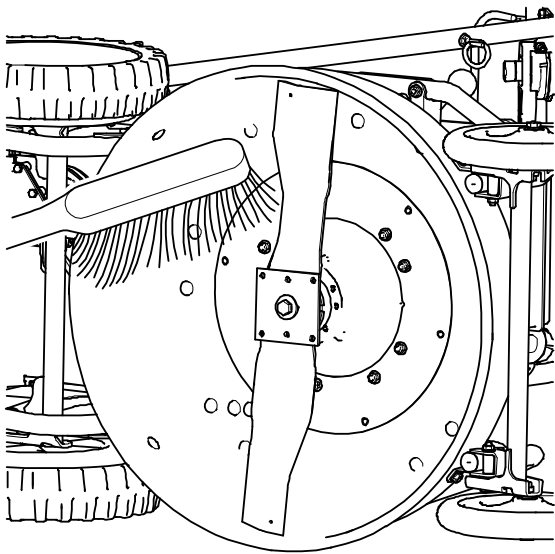

After each use, you should clean the device thoroughly, especially the bottom side and the blade.

Stuck grass or dirt affect the grass discharge and the cutting quality. For a sufficient engine cooling, keep the engine cover, ventilation grid, and the engine clean.

Fire hazard! Pay special attention so that components at the silencer are clean.

For cleaning use a hand brush. Remove stubborn soiling with a wooden or plastic spatula. Clean the outer housing parts with a cloth.

Do not rinse off the device with a water jet or high pressure cleaner! Do not use aggressive cleaning agents.

General inspection

To ensure a safe working condition of the device, check all nuts, bolts, screws, connections of fuel lines, air filters, etc. regularly for firm seating. Check the ignition wire and the spark plug connector for damage.

Change the damaged or used parts, especially covers, silencers or fuel tank immediately (authorized service centre).

Maintaining the engine



Danger!

If the speed of rotation is set too high, objects can be ejected. The engine can be damaged and noise pollution increases.

Do not change the basic setting of the carburetor or the speed control.

The operating instructions of the engine are prepared by the engine manufacturer. They contain the maintenance instructions and the warranty conditions for the engine. If warranty work for the engine is required, please contact your authorised service centre or the nearest authorised engine dealer.

Checking the engine oil level

The oil level must remain between the two markings of the oil dipstick. Make sure that the oil level is never below the bottom marking; otherwise the engine can be damaged. Never fill in oil above the top marking. Otherwise, there is a risk that the oil enters and destroys the air filter.

For this, observe the attached operating instructions of the engine.

Checking the spark plug



Danger!

The ignition system generates an electromagnetic field.

Wearers of pacemakers must not work on live parts.

Soiled spark plugs reduce the engine output. Clean the electrode of the spark plug with a brass wire brush. Check the electrode gap (see operating instructions of the engine manufacturer). Make sure that the insulator around the electrode is not damaged. Never use a damaged spark plug.

Tighten the spark plug using the correct torque (see operating instructions of the engine manufacturer).

Cleaning the air filter



Danger!

Cleaning agents pose a fire and explosion hazard.

Never clean the air filter with flammable solvents.

Always make sure that the air filter is clean. A dirty air filter affects the engine output and increases the fuel consumption. Independent from the number of operating hours the filter inserts should be changed at least annually. Do not operate the engine without air filter.

For this, observe the attached operating instructions of the engine.

Checking the drive

1. Put the device on a non-slip surface (e.g. concrete or asphalt).
2. Switch off the engine.
3. Actuate the drive.
4. Try to pull the device backwards.

If the rear wheels lock, the drive is correctly adjusted. If you can pull the device, the drive must be re-adjusted.

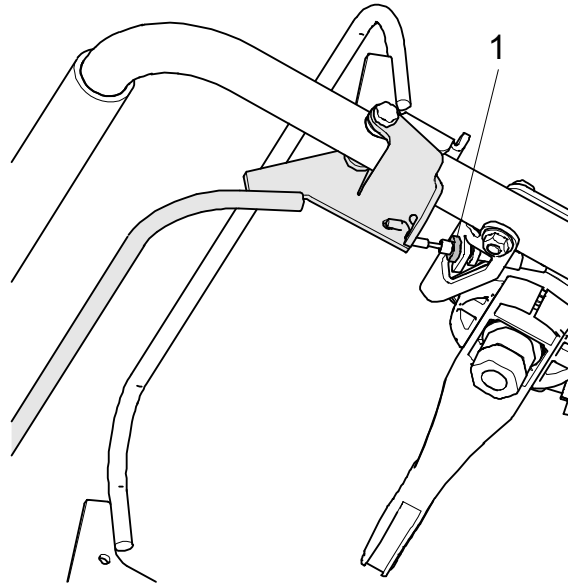

Re-adjusting the drive

Turn the adjusting screw (1) at the drive so that the wheels lock, while the drive is actuated, when the device is pulled. If there is no improvement after the adjustment, have the device checked by an authorised service centre.

Checking the blade



Danger!

Improperly mounted and maintained blades pose a severe injury hazard.

Work at the blade shall only be performed by an authorised service centre.

Work on the blade requires special qualifications because an unbalance test is required and the torques must be observed.

Check the blade and slip clutch regularly before and after each mowing and when there are significant changes.

Vibrations indicate that the blade is worn excessively or on one side.

Improperly sharpened blades increase the device load and result in fatigue cracks and breakage!

Ejected pieces can cause severe injuries.

Checking the blade

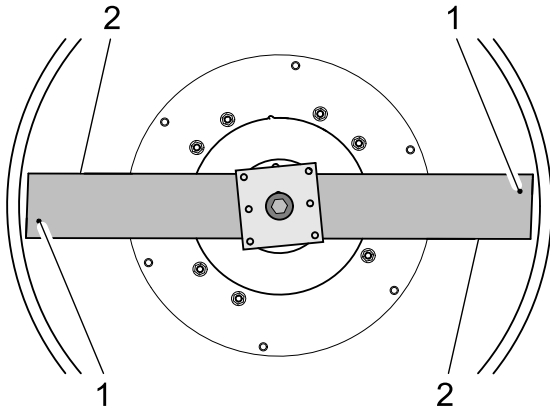

It is absolutely necessary to change the blade:

- When one of the wear markings (1) was reached. Original blade are engraved with wear markings (marking in form of a ball-shaped imprint on the rear side of the blade).
- When the thickness of the blade at the rear edge of the vane (2) or at another point is below 1 mm (exception: cutting edge).
- At the least once per year or every 50 operating hours, whether there is wear or not. The material deteriorates, may show cracks and this can endanger persons and material goods.

An original AS blade can be recognised by these imprints:



XXXX corresponds to the spare part number.

Checking the engine brake

Check the function of the engine brake by switching off the engine. The blade must come to a standstill from full speed within less than 3 seconds. Contact an authorised service centre if this is not the case.

Storage

Storing the device

Keep the device in a closed, dry, and well ventilated room and out of reach of children. Always eliminate all problems of the device before you store it so that the device is always in a safe-to-operate state. Let the engine cool down before you store the device in closed rooms.

Also observe the notices on storage in the attached operating instructions by the engine manufacturer.

Longer storage

1. Observe the safety instructions regarding the handling of fuel.
2. Draining fuel tank: Put a piece of a tube on the fuel valve and fill the fuel in an adequate fuel container.
3. Emptying carburetor: Start the engine and let it run until it stops on its own.
4. Clean the device thoroughly.
5. Touch up defects in painting (for spray paint, see Accessories).
6. Performing corrosion protection on the engine:
 - Unscrew the spark plug.
 - Fill a tablespoon of engine oil into the spark plug opening.
 - Pull the starter rope slowly until you get resistance (oil distribution in the cylinder).
 - Re-insert the spark plug and screw in fully.
 - Do not fit the spark plug connector!

In autumn, have your device checked by an authorised service centre!

Restarting

If you want to start the device after a longer storage, carry out the tasks described in chapter Maintenance.

Spare parts

The reliable and safe operation of the device also depends on the quality of the spare parts used. Only use original spare parts and accessories that were approved by “AS-Motor Germany”. When foreign parts are installed, the warranty and guarantee shall be void for the foreign part and for the device and for any resulting damage.

Inform your authorised service centre about the device type and serial number of your devices when you order spare parts.

Wear parts

Some parts are wear parts. They wear during use and must be replaced. The warranty does not cover the following parts:

Blades, cutting blades, cutter bars, blade bolts, sliding plates, V-belt, chains, Bowden cables, starter ropes, pressure plates, air filters, spark plugs, disc springs, lock washers, fuses, discs, thrust plates, pressure discs, protection skirts, impact protection, wheels, tires.

Accessories

Spray paint 400 ml, colour orange E04606

Operating hours counter E10740

5 liter tank E09132

Front and side protection E09133

Disposal

Grass clippings must not be thrown into the waste but should be composted.

Dispose of waste oil and fuel in accordance with the local regulations or return it to an oil shop.

Packaging, device, and accessories are made of recyclable materials and must be disposed off accordingly.

Warranty

The conditions of the warranty can be found on the reverse side of your warranty card. Send the filled-out warranty card immediately after the purchase of your device to “AS-Motor Germany” or the supplier. Otherwise, the warranty is no longer valid.

Preserve the proof of purchase or the warranty card that was filled out by the vendor.

Troubleshooting

You can find an authorised service centre on our home page www.as-motor.de.

The following table contains the most frequent problems and their elimination. If more problems occur, contact the closest authorised service centre.

Problem	Possible cause	Remedy
Engine does not start	Engine brake lever is not pressed.	Press engine brake lever towards the handlebar.
	Fuel valve is closed.	Open fuel valve.
	Tank ventilation screw is closed.	Open tank ventilation screw.
	No fuel is in the tank.	Refill fuel.
	Choke is open.	Close the choke.
	Device was tilted - air filter is oily.	Replace air filter, unscrew spark plug, and start several times while fuel valve is closed, dry spark plugs and screw back in.
	Engine was flooded due to too many start attempts.	Unscrew spark plug and start several times when the fuel valve is closed, dry the spark plug and screw it back in.
	Spark plug connector is pulled off.	Observe safety instructions! Put the spark plug connector on.
	Air filter is soiled.	Clean air filter (see also Maintenance and cleaning).
	Spark plug is sooted, damaged or incorrect electrode gap.	Clean air plug and check electrode gap (see also Maintenance and cleaning). Replace spark plug if necessary.
	Housing of the mower is jammed.	See also Maintenance and cleaning.
Engine starts badly or runs irregularly	Poor quality, dirty, or old fuel.	Clean fuel system (authorised service centre). Always use fresh fuel.
	Blade is loose.	Authorised service centre.
	Air filter is soiled.	Clean air filter (see also Maintenance and cleaning).

Problem	Possible cause	Remedy
	Poor quality, dirty, or old fuel.	Always use fresh fuel.
	Spark plug is sooted, damaged, or incorrect electrode gap.	Clean spark plug and check electrode gap (see also Maintenance and cleaning). If necessary, replace spark plug.
	Housing of mower is jammed.	See also Maintenance and cleaning.
No drive when drive lever is actuated	Driving belt is insufficiently tensioned.	Authorised service centre.
The blade slides	Replace friction discs.	Authorised service centre.
Strong vibrations during operation	Unbalance at the blade caused by incorrect sharpening or chips on the blade.	Have blade balanced and re-sharpened by an authorised service centre. Replace a damaged blade immediately.
	Blade drive shaft is bent by collisions with foreign objects.	Authorised service centre.
	Engine fastening is loose.	Authorised service centre.
	Blade fastening is loose.	Authorised service centre.
Irregular noises	Loose fastening elements.	Authorised service centre.
	Silencer defective.	Authorised service centre.
Engine is smoking	Air filter is soiled or drenched with oil.	Clean or replace the air filter (see also Maintenance and cleaning).
	Oil level is too high.	Have authorised service centre lower the oil level to the marking.
Engine gets hot	Ventilation grid is dirty.	Clean ventilation grid.
	Oil level in the engine is too low.	Refill engine oil (see operating instructions of the engine manufacturer).
	Cooling fins of the engine are dirty.	Have cooling fins cleaned by authorised service centre.
Uneven cut, lawn becomes unsightly	Blade is dull or worn.	Have blade balanced and re-sharpened by an authorised service centre. Replace a damaged blade immediately.
	Speed is too high proportionately to the cutting height.	Reduce speed and/or select the correct cutting height.

Problem	Possible cause	Remedy
	Housing of mower is heavily soiled.	Clean.
Housing is jammed	Mowed grass was too long or too damp.	Adjust cutting height and mowing speed to the mowing conditions.
	Blade is worn.	Authorised service centre.
	Engine speed too low.	Authorised service centre.
The device does not stop	Drive belt does not declutch.	Authorised service centre.
The engine does not switch off	Switching off system is defective.	Close the fuel valve. Authorised service centre.

Technical data

Type	AS 510 A ProClip
Range of application (temperature)	5 – 30 °C
Engine, type Manufacturer Type Cylinder capacity Performance Engine speed	Single cylinder four-stroke engine Briggs & Stratton 850 series 190 cm ³ 3.1 kW (4.3 PS) 2800 min ⁻¹ See also operating instructions of engine manufacturer.
Cutting device, type Cutting width Cutting height adjustment Plant growth	Blade 51 cm central 40 – 90 mm, in 6 levels (40 mm, 50 mm, 60 mm, 70 mm, 80 mm, 90 mm) up to approx. 20 cm
Starting device	Rope start
Drive	Rear wheel drive with Variomat for continuous speed adjustment (2.0 – 4.0 km/h)
Maximum output per unit area	approx. 2040 m ² /h
Measures and weight Transport size with packaging L/W/H Tire dimensions L/W/H Weight	120/60/71 cm 139/55/100 cm 43 kg
Capacities Fuel tank Engine oil	1.2 litres 0.65 litres
Sound level Measured sound level L _{WA} Guaranteed sound level L _{WA} Sound level at working place L _{pA}	92.4 dB according to DIN EN 836 93 dB according to DIN EN 836 83 dB according to DIN EN 836
Vibration emission value Hand-arm-vibrations a _{h,w} Measurement uncertainty U	4.2 m/s ² according to DIN EN 836 1.5 m/s ²



AS-Motor Germany GmbH & Co. KG
Ellwanger Straße 15
D-74424 Bühlertann
www.as-motor.de

Declaration of conformity

We declare that the lawnmower type
cutting width 51 cm and with the serial number

AS 510 A ProClip
starting from
022711030001

in the version we introduced to the market complies with all
essential health and safety requirements of the following EC
directives.

- 2006/42/EC
- 2000/14/EC
- 2004/108/EC
- 97/68/EC

Function:

The device is exclusively intended for the mowing of well
maintained grasslands and lawns.

Applied standards:

EN 836

Applicable for 2000/14/EC:

Applied conformity assessment procedures:

Measured sound level:

Annex VI

Guaranteed sound level:

92.4 dB (A)

93 dB (A)

Party involved:

DPLF, D-64823 Groß-Umstadt, EC identification number 0363

Place where all technical records are filed:

AS-Motor Germany GmbH & Co. KG

Ellwanger Straße 15

D-74424 Bühlertann

Bühlertann, July 2010

Christoph Weber
Managing director

By proxy Frank Einsiedler
Head of development



AS-Motor Germany GmbH & Co. KG
Ellwanger Straße 15
D-74424 Bühlertann
www.as-motor.de

Professional technology for gardens and landscapes

Allmäher®	Manoeuvrable meadow mower for extensive green area care. The Allmäher reliably shreds high grass, scrub, and weeds also on steep slopes and in difficult terrain. The grass cuttings are left to fertilise the ground so there is no more raking grass.
Ride-on Allmäher®	Ease of use and high area coverage all combined in a compact lawn mower. Low centre of gravity, optimum weight distribution, and broad wheel base provide you with the best performance on slopes and power reserves for shredding high plant growth. Also available in an all-wheel version providing the extra traction for demanding applications and for superior safety on slopes.
Rear discharge mower	Professional lawn mower with rear discharge. With wheel drive and infinite speed regulation for exceptional cutting and catching performance in any situation.
Rotary mower	The economic alternative to bar mower. Ideal for fodder production. The grass is not shredded and placed into a pile on the side.
Flail mower	The flail mower blades are supported movably and avoid rocks and other obstacles and chop the cuttings several times. The steel housing is 3 mm thick and offers very high security against foreign objects that were ejected and blown around and catches them safely.
Side discharge mower	This solid allrounder has a side discharge, wheel drive, and a housing of 3 mm thick plastic-coated steel. Also available in an all-wheel drive version and infinite speed regulation (Variomatic).
WeedHex	Removes weeds carefully, quickly, and without the use of chemicals: on transport surfaces, walls, curbs, and between interlocking blocks. The patented pivoting brush system goes easy on surfaces and is environment-friendly regarding harmful herbicides.