

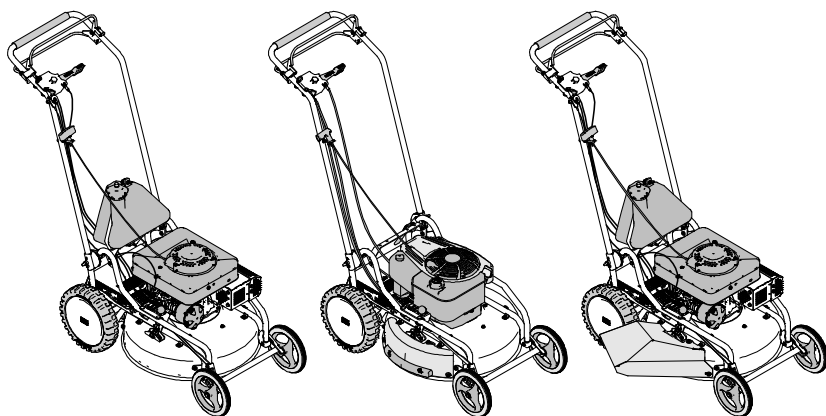

Operator's Manual



Mulching Mower

AS 510 4T A, AS 510 2in1 4T A,
AS 510 2T ES A, AS 510 2in1 2T ES A

From serial number: AS 510 4T A: 022711030001, AS 510 2in1 4T A: 031418020001,
AS 510 2T ES A: 030617050001, AS 510 2in1 2T ES A: 031318020001

Issued: 01 March 2018, V9.0

en-Translation of the Original Operator's Manual

Notes on the operating manual

Dear customer,

Congratulations on your purchase. You have acquired a reliable quality product by "AS-Motor Germany".

This product has been manufactured according to modern manufacturing methods and comprehensive quality assurance measures. Only when you are satisfied with your device, we have attained our goal.

These operating instructions contain important information to help you avoid hazards and to increase the reliability and the life span of the device.



Read the operating instructions before using the device. Share these operating instructions and the operating instructions of the engine with other users of the device.

Contact

If you have questions concerning your device, please contact your dealer or call our customer service (+49 7973 9123-0).

For international AS partners, please see: www.as-motor.de.

Device data

Please fill in all data referring to your device. When ordering spare parts, provide your dealer with the serial and engine numbers.

Serial number (see manufacturer's certificate or type plate):

Engine number:

Date of purchase:

Address of dealer:

Intended use

The device is exclusively intended for mowing well maintained grassed lawn areas.

Only use attachments and cutting tools authorised by "AS-Motor Germany".

Any other use exceeding this purpose is inadmissible.

Observe the instructions chapter for Maintenance. Otherwise, operational safety is endangered.

The user of the device is responsible for accidents or damage that can happen to other persons or their property.

The device **must not** be used:

- To cut hard objects, rocks, rubble, or pieces of wood.
- To trim bushes, hedges, and shrubbery.
- To cut plants in flower pots or planters or on rooftops.
- To clean (vacuum) footpaths.
- As shredder for shredding tree and hedge cuttings.
- As drive unit for work tools and any type of tool sets that are not authorised by "AS-Motor Germany".

Contents

Notes on the operating manual	2	Transport	18
Contact	2	Maintenance	19
Device data	2	Maintenance overview.....	20
Intended use	2	Cleaning the device.....	22
Explanation of the symbols	4	General inspection.....	22
Symbols in the instructions.....	4	Checking the traction drive.....	22
Symbols on the device.....	4	Checking engine brake.....	23
Type overview	5	Checking the blade.....	23
Safety instructions	6	Maintenance especially for 4-stroke devices	24
Get informed!.....	6	Maintaining the engine.....	24
User restrictions and hours of operation..	6	Checking the engine oil level.....	24
Safe handling of fuel.....	6	Checking the spark plugs.....	24
Check the device prior to use.....	7	Maintaining the air filter.....	24
Danger area.....	7	Maintenance especially for 2-stroke devices	25
Use caution during operation.....	8	Maintaining the engine.....	25
Prior to mowing.....	8	Checking the spark plugs.....	25
Use caution when mowing.....	8	Maintaining the air filter.....	25
Caution when mowing slopes.....	9	Assembly	26
When work is completed.....	10	Scope of delivery.....	26
Use caution during maintenance and repair.....	10	Unpacking.....	26
Device description 4-stroke devices	11	Mounting guide bar and handlebar.....	26
Device description 2-stroke devices	12	Mounting the impact protection (only 2in1).....	26
Control elements	13	Storage	27
Especially for 4-stroke devices.....	13	Storing the device.....	27
Especially for 2-stroke devices.....	13	Longer storage.....	27
Information on mowing	14	Restarting.....	27
Prior to starting	14	Spare parts	27
Fuel used (2-stroke devices).....	14	Wear parts	27
Fuel used (4-stroke devices).....	15	Disposal	27
Check engine oil level (4-stroke devices)	15	Warranty	28
Tanking up.....	15	Troubleshooting	29
Adjusting cutting height.....	15	Accessories	32
Attaching the starter grip.....	16	Fuel ratios of fuel 2-stroke devices	32
Starting	16	Technical data 4-stroke devices	33
Starting the device (2-stroke device).....	16	Technical data 2-stroke devices	34
Starting the device (4-stroke device).....	17	Declaration of conformity	36
Driving	17		
Driving.....	17		
Turning.....	17		
Switching off and parking	18		

Explanation of the symbols

Symbols in the instructions

In these operating instructions, the following symbols are used to denote special dangers.



Warning.
These symbols denote special dangers.



Prohibition sign.
These symbols denote inadmissible procedures.



Directive sign.
These symbols denote required protective measures.

Symbols on the device

The following symbols are placed on the device to inform you must be careful and attentive when using the device:



Working with the device requires extreme cautiousness.
Read the operating instructions before you use the device.



Risk of injury!
Make sure that no one is within the danger zone of the device.
Objects may be ejected.



The quickly rotating blade can cause life threatening injuries or immense property damage! Be especially careful to keep your hands and feet away from the blade when the device is put into operation.

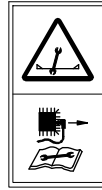

Prior to any repair and maintenance work, pull off the spark plug connector.



Clean the ventilation grid!
The cooling air of the motor is sucked in through the ventilation grid of the engine cover. Always keep the entire surface open and free!



Noise is causing health problems. Use personal ear protection to avoid hearing damage.



Hot surface. Do not touch the engine or the silencer. They become very hot during operation and you can get burned.



Do not clean the device with water spray or high-pressure cleaner!

Type plate

The type plate on the device provides you with information on the device type and the technical data.

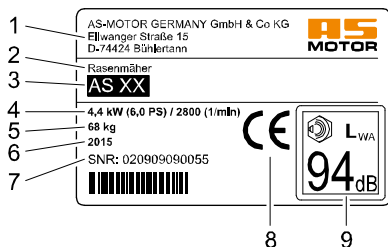

- 1 Name and address of the manufacturer
- 2 Device designation
- 3 Type designation
- 4 Rated power output in kW / engine speed
- 5 Weight
- 6 Year of manufacture
- 7 Serial number
- 8 CE marking
- 9 Sound level L_{WA}

Type overview

In this operating manual, the following device types are described. Depending on the equipment of your device, the corresponding descriptions of this operating manual apply.

The illustrations in this operating manual may show different device types.

Equipment	510 4T A	510 2in1 4T A	510 2T ES A	510 2in1 2T ES A
2-stroke engine	-	-	X	X
4-stroke engine	X	X	-	-
Tank ventilation	-	-	X	X
Mulching plate and impact protection	-	X	-	X

Safety instructions

Get informed!

For your safety, read these operating instructions carefully. Familiarize yourself with the control elements and the proper use of the device. Share these operating instructions with other users of the device.

Have skilled personnel who were trained by AS-Motor show you the safe handling of the device before you work with it for the first time.

Get familiar with the device in a wide, open and flat terrain first.

User restrictions and hours of operation

Never allow children or persons who are not familiar with the operating instructions to use the device. Persons under 18 years of age may operate the device only under proper supervision. Local regulations determine the minimum age of the operator and the operating times.

Unsuitable for operation of the device are persons who

- are under the influence of alcohol, drugs or reaction retarding medicines.
- have physical and mental/emotional impairments.
- are tired or sick.



People fitted with pace makers are not allowed to touch any current carrying parts of the ignition system.

Safe handling of fuel

Fuel is toxic and highly flammable. There is a burn and explosion hazard!

Keep fuel away from ignition sources and do not smoke during handling.

Do not inhale fuel vapours, they are dangerous to your health.



Use gloves and avoid skin contact with the fuel.

Always refuel outdoors when the engine is cold and standing still. When doing so, always use a filler spout or a funnel.

Do not spill any fuel or do not let fuel enter canalisation or drain away.

When fuel has overflowed, do not start the device until the fuel vapours have evaporated (wipe dry). Move the device away from the spilled fuel.

Always close the tank cap tightly and do not open it while the engine is running or the device is still hot.

Empty the fuel only when outdoors. Use the approved container for this or run the fuel tank empty.

Store the fuel away from children and keep it in a suitable container in a dark, cool and dry place.

Never store the device when there is fuel in the tank inside a building where fuel vapours might come into contact with open fire or sparks.

Immediately replace the fuel tank or tank cap if they are damaged (authorised service centre).

First aid

When swallowing fuel or inhaling fuel vapours, do not force vomiting and immediately consult a doctor.

In case of skin contact, immediately wash with water and soap. Change your soiled clothing as soon as you can.

Measures in case of a fire

In case of a fire, use foam, dry powder extinguisher, or carbon dioxide (CO₂). Never douse with water!

Check the device prior to use

Prior to use, check the blade, drive and fastening parts, cables and cable connections for proper working condition and firm seating by visual inspection.

Never use the device with defective or missing covers, impact protection or mulching plate.

Do not remove, change or override any safety devices or control elements.

Observe the maintenance instructions (see Maintenance).

Have an authorised service centre check your device if the blade does not stop within 3 seconds.

Danger area

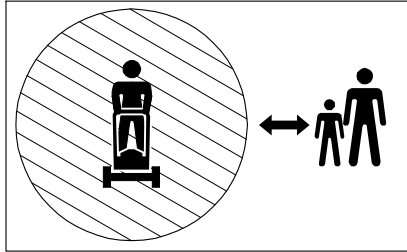

Within the danger area of the device, there is a risk of injury.

The rotating knife can cause injuries and objects can be thrown out. The area in front of and to the right of the device is especially dangerous.

On slopes, the device can topple over and slide towards persons or run them over.

Make sure

- that nobody else is in the area that will be mowed.
- that people are never positioned in the direction of travel in front of the device.
- that nobody is positioned on the slope below the device.
- that you have a complete overview of the danger area at all times.
- that you keep your hands and feet away from the rotating parts.

Use caution during operation

Danger of injury during motor start

Do not start the engine

- if fuel was spilled.
- in closed or poorly ventilated rooms (danger of poisoning!).
- if there are other persons nearby.

Start the device only when your feet are at a safe distance to the blade.

Start the device only when the starter rope is fixed to the guide.

When the engine is started, do not tilt the device.

Risk of injury when the motor is running

Switch off the engine and wait until the blade stops

- before you tilt or transport the device.
- before you step away from the device, even for just a short time.
- when you drive on surfaces other than grass.
- before you adjust the cutting height.
- before you refuel.

Switch off the engine and wait until the blade comes to a standstill, and pull off the spark plug connector

- before you clean or check the device or before you carry out work on the device.
- before you unblock or unclog the discharge area.

Risk of burns

Do not touch the engine or the silencer. These parts become very hot during operation and you can get burned. If a jumpy movement occurs, the risk of additional injuries can result.

Prior to mowing

Personal protective measures



During mowing, always wear safety shoes with good grip and long trousers. Do not mow with open sandals or while shoeless.



Wear safety gloves to protect yourself against injuries and vibrations.



Noise is causing health problems. Use personal ear protection to avoid hearing damage. Wear safety glasses and headgear.

Ask your specialised dealer about suitable protective equipment.

Preparing the mowing area

Prior to mowing, carefully check the perimeter of the lawn. Remove rocks, pieces of wood, bones, wires, and other objects that could be picked up and thrown out by the device.

Use caution when mowing

Risk of injury

Risk of injury caused by ejected objects. Never mow when persons, children, pets or material assets are in the danger area.

Keep your hands and feet away from the rotating parts. Keep a distance to the ejection area while working with the device.

Make sure that help can be provided in case of an emergency.

Only mow during daylight or with adequate artificial lighting. Never mow in the event of uncertain weather conditions and risk of lightning.

Be especially carefully when mowing on soft ground, nearby landfills, ditches, dikes and water edges.

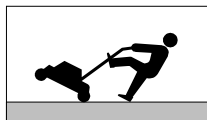

Avoid mowing damp grass, there is a sliding risk!

Be extremely cautious when turning the device round or pulling it toward you and when moving in reverse.

Always walk slowly!

Never lift or carry the device when the engine is running.

Pay attention to traffic when working close to roads.

Vibrations

When the device is used over a longer period of time, vibrations can cause disturbances in the blood supply of the hands. A generally accepted usage time cannot be determined.

- Use gloves.
- Take breaks on time.

Have an authorised service centre check the device

- when the blade has hit an object.
- if the device starts to vibrate unusually severely.

Mowing surfaces with fire hazard

- Carry a sufficient amount of suitable extinguishing agent.
- If side inclination is too great, fuel may leak from the carburetor or the tank. This poses a fire hazard!
- Observe the mowed surface also after moving is completed to ensure that no fire will start.

To avoid risk of fire, keep the following components free of dirt, grass, hay, leaking oil, grease, etc.:

- Engine
- Silencer (manifold, guard, clearances)
- Area around the fuel tank

Caution when mowing slopes



Risk of injury during mowing on slopes due to tipping over or sliding.

- Mow on steep terrain only when safe operation can be guaranteed.
- Do not mow excessively steep slopes.
- Take suitable precautions on steep slopes, e.g. by using step irons.
- Always mow crossways to the slope, never upwards or downwards.
- Always pay attention to step safely, wear non-slip safety shoes.
- Be extremely cautious when changing the direction.
- Mow only when the ground is dry and has a good grip.

When facing downhill, the device can roll away. Park the device on level ground only and secure it against rolling away.

Devices fitted with a four stroke engines may only be operated on less than 20° slopes. Otherwise, the four stroke engine can be damaged due to insufficient oil lubrication.

If the device tilts or slips

- If you attempt to stop a device that is tilting or slipping, severe injuries can result. If tilting or sliding cannot be stopped in the beginning without endangering anyone, do not continue to try to stop the device.
- Remove leaking fluids (oil, fuel, battery acid) from the device and the floor. Deposit of contaminated soil environment friendly according to the local regulation.
- Undetectable damage may have occurred to the device. In case of malfunctions, there is a risk of injury. Have an authorised service centre check the device.

When work is completed

After each mowing, close the fuel valve and the tank ventilation.

Prior to leaving the device, wait until the motor comes to a standstill and pull off the spark plug connector.

After switching it off, let the device cool down for at least 20 minutes before you store it in a dry, closed, sufficiently ventilated room.

Never store the device when there is fuel in the tank inside a building where fuel vapours might come into contact with open fire or sparks.

Use caution during maintenance and repair

Only carry out work as described in these operating instructions. Have an authorised service centre perform all other work.

Only use the blades and spare parts authorised by "AS-Motor Germany". Unauthorised blades and spare parts can cause severe injuries.

Prior to all maintenance work, wait until the engine comes to a standstill and pull off the spark plug connector.

We explicitly point out that, in accordance with the Product Liability Act, we are not liable for damages that were caused by our devices if

- worn or damaged parts were not repaired or replaced on time.
- these damages were caused by improper repair.
- when changing a part, our original parts or parts authorised by us were not used.
- the repair work was not carried out by an authorised service station.

The same applies for spare parts and accessories.

Device description 4-stroke devices

Abbildung zeigt AS 510 2in1 4T A

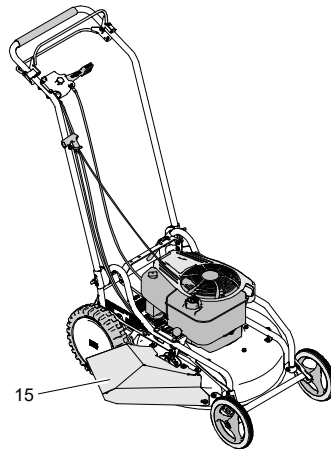
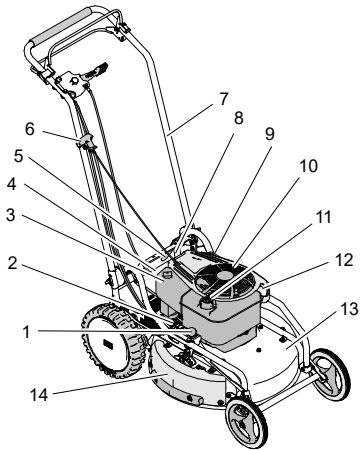

- 1 Cutting height adjustment
(40 mm, 50 mm, 60 mm, 70 mm,
80 mm, 90 mm)
- 2 Fuel valve
- 3 Air filter
- 4 Type plate
- 5 Eccentric tension lever for bar
mounting
- 6 Starter grip
- 7 Guide bar with control elements
- 8 Spark plug connector
- 9 Silencer
- 10 Ventilation grid
- 11 Tank filler spout
- 12 Oil filler opening
- 13 Cover
- 14 Exchangeable mulching plate
(only 2in1)
- 15 Exchangeable impact protection
(only 2in1)

Device description 2-stroke devices

Figure shows 510 2in1 2T ES A

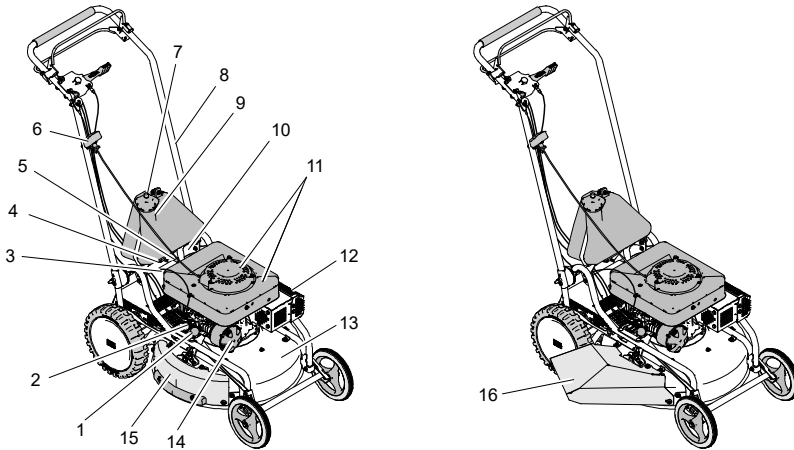

- 1 Cutting height adjustment
(40 mm, 50 mm, 60 mm, 70 mm,
80 mm, 90 mm)
- 2 Choke
- 3 Type plate
- 4 Fuel valve
- 5 Eccentric tension lever for bar
mounting
- 6 Starter grip
- 7 Tank ventilation
- 8 Guide bar with control elements
- 9 Tank filler spout
- 10 Spark plug connector
- 11 Ventilation grid
- 12 Silencer
- 13 Cover
- 14 Air filter
- 15 Exchangeable mulching plate
(only 2in1)
- 16 Exchangeable impact protection
(only 2in1)

Control elements

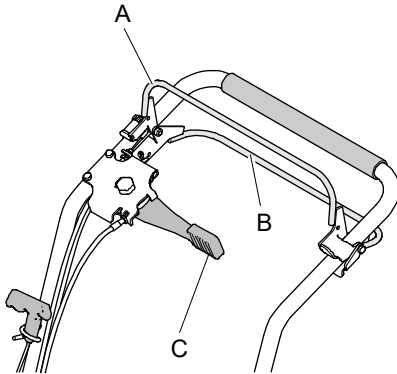

Engine brake lever (A)

The engine brake lever is a guard device. When you release the lever, the engine is shut off immediately, the knife comes to a standstill within 3 seconds.

Operating position:

Press the engine brake bar towards the handlebar.

Switching off the engine:

Release the engine brake lever.

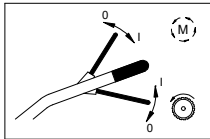

Top:
Engine brake bar

Bottom:
Drive bar

Drive bar (B)

With the drive bar, you switch the drive on and off.

Drive on:

Pull the bar toward the handlebar

Drive off:

Release the bar

Vario lever (C)

With the vario lever, you can continuously adjust the speed of the device while the engine is running.

MIN: slow

MAX: fast

Especially for 4-stroke devices

Fuel valve

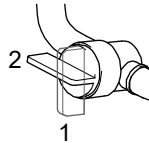

1: Closed

2: Open

Especially for 2-stroke devices

Carburetor with choke and tickler

The choke (1) and the tickler (2) are required for the cold engine start.

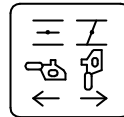

Opening the choke:

Turn clockwise to the stop.

Closing the choke:

Turn anti-clockwise to the stop.

Filling carburetor with fuel:

Press the tickler briefly until the fuel flow starts.

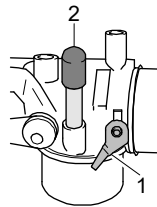

Fuel valve

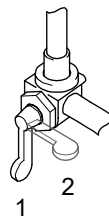

1: Open

2: Closed

Information on mowing

Prior to mowing, check your device for completeness, proper functioning, and cleanliness. A dirty ventilation grid causes overheating of the engine, this can damage the engine. A dirty protective grid at the silencer poses a fire hazard.

For your grass to grow beautiful and thick, mow frequently and keep the grass short. Do not mow your lawn too low in dry and hot conditions because the lawn is susceptible to sun and heat damage and will look unsightly!

Only mow with a sharp and undamaged blade so that the blades of grass do not fray. Have the blade sharpened and balanced regularly (authorised service centre).

Do not mow when the grass is wet or when it is raining. The turf may be damaged and there is a danger of slipping!

Turn the device around only in already mown sections. Do not leave the device unattended while the engine is running.

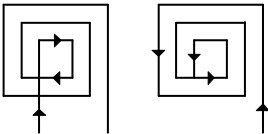

To evenly distribute grass remains and to achieve an even cutting height, we recommend, for flat terrain, to proceed according to the illustrated mowing pattern.

A mulching mower shreds the clippings better and finer than a conventional mowers. For an optimal cutting pattern, please heed the following recommendations.

Recommendations for mowing with mulching mowers:

- Mow only 1/3 of the grass height.
- Do not set the brush height to the lowest position. Recommendation: 50-60 mm.
- Work under dry conditions.
- Start with slow speed.
- The slower you drive the better the cutting result.

- If the grass is too high, you should mow in maximum cutting height first and later mow again in the recommended cutting height.
- If clumps form or the mulching layer is too thick, the air exchange of the soil can be restricted. Areas of rot can result.

Recommendations for using the side discharge for mowers with 2in1 function:

- You can mow higher and thicker grass with the side discharge if perfect mulching is not possible any longer.
- The cut grass is ejected quicker and the mower does not clog.
- Disadvantage: Visible cut grass on the lawn. No mulching function. It is only possible on the left side to mow close to the edge.

Prior to starting

Fuel used (2-stroke devices)

The engine must be run on a mixture of petrol and two-stroke oil.

For possible mixing ratios, see chapter Mixing ratios fuel.

Use unleaded petrol (octane rating at least ROZ 91). You can use E10 petrol. Do not store E10 petrol longer than 30 days. Do not use fuels with more than 10 % ethanol (e.g. E15, E85).

Only use fully synthetic two-stroke oil intended for mixing in ratio 1:50. Do not use any mineral two-stroke oil.

AS-Motor recommendation:

Fully synthetic two-stroke oil **TITAN 2T 100S** in ratio **1:100**.

Your benefits:

- **Halve oil consumption compared to 1:50** - therefore more environmentally and cost friendly.
- Optimum protection of the engine for a long service life.
- Low engine wear.
- Maximum engine performance.

You can buy Fuchs "TITAN 2T 100S" of from your AS-dealer:

Container	ET no.
1 litre (resealable bottle)	G00041042
100 ml (disposable container)	G00041056
40 * 100 ml (disposable containers in box)	G00041058

Notice: You can find on the market ready mixed two-stroke fuels. Based on our experience, the ready mixed fuels "STIHL Motomix 1:50", "ASPEN 2-stroke" and "Oest Oecomix" can be used. No guarantee can be given for operation of the device with other fuels and oils!

Do not use mixtures with more oil than 1:50 (e.g. 1:35).

Too much oil results in carbon deposits and reduces the service life of the engine.

Only use the fully synthetic two-stroke oils explicitly intended for mixing.

Use of engine oils or even waste oil results in engine damage.

No warranty is given in these cases.

Storing fuel mixture

The fuel mixture ages and can cause engine damages. Only mix as much fuel as you are going to use up during the next mowing.

Fuel used (4-stroke devices)

As fuel, use unleaded petrol (see operating instructions of the engine manufacturer).

You can use E10 petrol. Do not store E10 petrol longer than 30 days.

Check engine oil level (4-stroke devices)

Attention! Prior to each use, check the engine oil level (see operating instructions of the engine manufacturer).

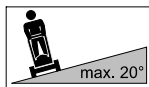

To ensure sufficient oil supply for the four stroke engine and to avoid resulting engine damage, the device may only be used on slopes up to 20°.

Tanking up



Danger!

Fuel is ignited by hot engine parts.

Prior to filling up, switch off the engine and wait for at least 20 minutes until the engine has cooled down.

Observe the safety instructions regarding the fuel!

Filling up with fuel

1. For filling, use a canister with filler spout or a funnel.
2. Open the canister carefully so that existing excess pressure is slowly reduced.
3. Open the tank cap carefully so that existing excess pressure is slowly reduced and no fuel sprays out.
4. Fill the fuel tank.
5. Tightly close the tank cap again.

Adjusting cutting height

Adjust the cutting height setting only when the engine is switched off.

Set the cutting height so that the blade does not touch the ground even in case of terrain unevenness. If the cutting height is set too high, objects can be ejected and the "clean cut appearance" can be destroyed.

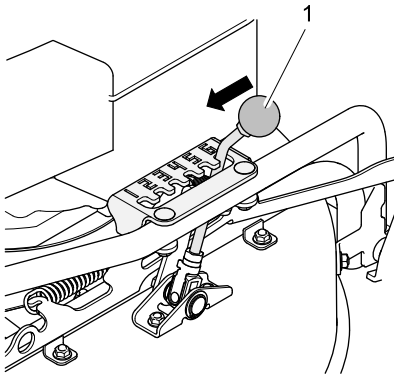

1. Switch off the engine and wait until the blade has come to a standstill.
2. With the central adjustable lever (1) adjust the cutting height. The cutting height can be adjusted in 6 levels from 4 cm to 9 cm.

Attaching the starter grip

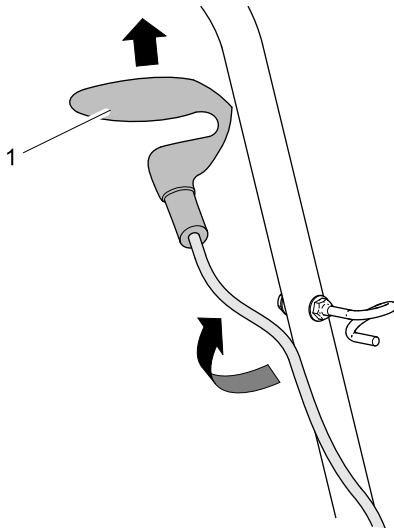

1. Slowly pull the starter rope at the starter grip (1) to the rear and slide it into the guide.

Starting



Danger!

During startup, there is a risk of injury caused by the rotating blade.

Make sure that no one is within the danger zone of the blade. Do not tip the device over to one side during startup.



Danger!

If after startup the carburetor does not close properly, fuel will overflow and a fire hazard occurs.

Close the fuel valve and contact an authorised service centre.

Starting the device (2-stroke device)

1. Place the device on even terrain, not in high grass.
2. Pull the starter grip slowly to the rear and attach it onto the starter grip holder.
3. Close the fuel valve and the tank ventilation.
4. Plug in the plug connector.
5. Only for cold start: Close the choke at the carburetor (turn anti-clockwise).
6. Press the tickler at the carburetor until fuel flows.
7. Actuate and hold the engine brake handle.
8. Pull the starter grip slowly out until you feel resistance and then pull out quickly – engine starts to run.
9. Slowly bring the starter grip back and attach it onto the starter grip holder.
10. Reopen the choke (turn clockwise).

Starting the device (4-stroke device)

1. Place the device on even terrain, not in high grass.
2. Pull the starter grip slowly to the rear and attach it onto the starter grip holder.
3. Open the fuel valve.
4. Plug in the plug connector.
5. Actuate and hold the engine brake handle.
6. Pull the starter grip slowly out until you feel resistance and then pull out quickly – engine starts to run.
7. Slowly bring the starter grip back and attach it onto the starter grip holder.

Driving



Danger!

Risk of injury caused by tripping or sliding while pushing the mower, moving it backwards and turning it round.

Make sure that the area is clear of objects and watch for safe footing.

Driving

In case of a dangerous situation, switch off the blade by releasing the engine brake bar.



Notice!

If you do not engage the traction drive completely, the transmission will be overheated and damaged.

Do not try to control the driving speed with the drive bar.

Always pull the drive bar all the way towards the handlebar.

Check regularly the settings of the traction drive, at the latest when the driving force diminishes (see Maintenance).

Drive on

1. Use the varioshift lever to set the desired speed.
2. Press the drive bar towards the handlebar – device starts moving.

Drive off

1. Release the drive bar.

Adjusting speed

With the vario lever, you can continuously adjust the speed of the device.

Only adjust the driving speed when the engine is running; otherwise, the vario drive can be damaged.

Turning

Turn the device round only where the grass has been mowed already.

Turning round on an even surface:

1. Switch off the drive.
2. Turn the device to the desired side.
3. Switch the drive back on.

Turning round on a sloping area:

1. Keep the drive switched on.
2. Turn the device upslope.
3. Hold back the handlebar and the inner wheel.

The drive prevents sliding and supports the turn manoeuvre.

Switching off and parking



Caution!

On a slope, the device can roll away.

Put the device on even ground only or secure it against rolling away.

1. Release the drive bar.
2. Release the engine brake bar.
3. Wait for the engine to stop completely before you step away from the device.
4. Close the fuel valve and the tank ventilation (if existing).
5. Pull off the plug connector.

Transport

Switch off the engine and wait until the blade comes to a stop before you lift the device. It takes two persons to safely lift the device.

Prior to transport, let the device cool down for at least 20 minutes. Close the fuel valve.

For transport, you can fold up the guide bar.

During transport on vehicles, secure the device against rolling, sliding, tilting, and fuel leakage.

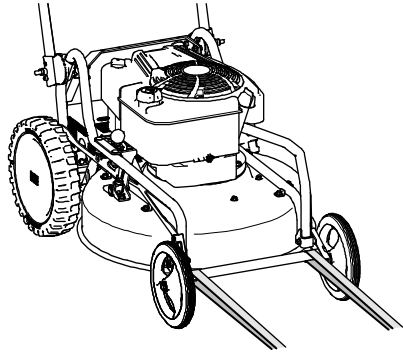
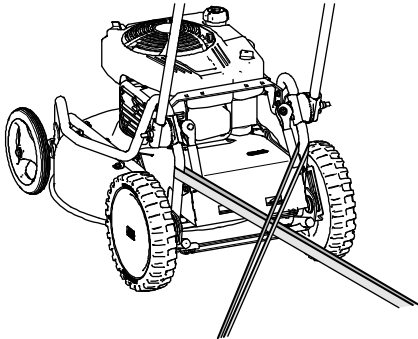

Use straps that support the weight of the device to secure the device.



Notice!

Risk of damage due to incorrect fastening of straps.

Fasten the straps only at the points shown in the figure.

Do not overtighten the straps.

Maintenance



Warning!

Risk of injury due to unexpected movement. When inspections are carried out, the device can move unexpectedly.

Make sure that no persons or objects are in the danger area of the blade.

Make sure that no further hazards result from an unexpected movement.



Warning!

Risk of injury during maintenance and cleaning work when the engine is running.

Perform maintenance tasks only then with a running engine if this is required in the Maintenance table.

Prior to all maintenance and cleaning work when the engine is not running:

1. Let the device cool down for at least 20 minutes.
2. Pull off the plug connector.
3. Close the fuel valve and the tank ventilation.
4. For work on the bottom side of the device, flip the device to the silencer side.

Improper maintenance can make the device unsafe for operation and result in accidents. Regular maintenance keeps your device ready for use.

Service the device according to the following maintenance instructions.

Contact an authorised service centre if problems during maintenance occur or if you determine deficiencies during one of the following inspections.

Maintenance overview

Component	Action	Maintenance interval	
		A	B
Device	Check for safe working condition (basic inspection).	■	▲
	Clean.	■	
	Customer service.		▲
Fuel	Check fuel level.	■	
	Is the tank cap closed?	■	
Tank, fuel valve, and fuel line	Check parts for leaks and check for good condition.	■	▲
Carburetor	Does the carburetor close again after starting?	■	▲
Ventilation grid	Clean.	■	▲
Engine cooling	Clean.		▲
Spark plug	Check/replace.		▲
Air filter	Maintain.	■	■▲
Blade and fastening components	Check for wear and damage. See chapter Checking the blade.	■	▲
	Change.		▲
Motor brake	Does the knife stop within 3 seconds?	□	▲
Drive bar	Does the device stop when the bar is in zero position?	□	▲
Drive	Check.	■	▲
V-belt	Are the belts tensioned correctly, without fissures, and in good condition?		▲
Bowden cables	Check for proper function and ease of movement.	■	▲
Chassis and impact protection	Check for rust and fissures and check the welding seams.	■	▲
	Are all protective devices and covers in place, fastened correctly and properly functioning?	■	▲
Label	Condition of the labels.	■	▲
Flammable material	Remove easily flammable debris buildup from the engine and the device.	■	▲
Tyres	Check tyres and, if necessary, the tyre pressure.	■	▲

For 4-stroke devices:

Engine	For reliable information, see the operating manual of the engine manufacturer.	■	▲
	Check oil level (see operating instructions of the engine manufacturer).	■	▲
	Oil change.		▲

A Before and after each use.

B Annually or every 50 h.

■ By the user when the engine is not running.

□ By the user when the engine is running.

▲ By the authorised service centre.

Cleaning the device

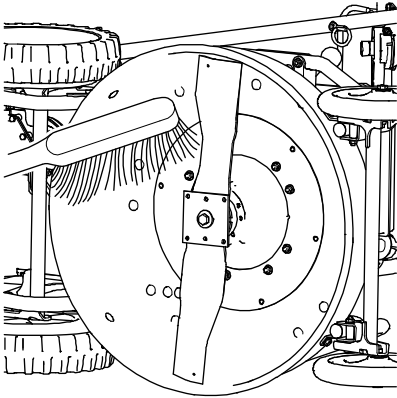

Depending on use, clean the device thoroughly, especially the bottom and the blade.

Grass cuttings and dirt that are stuck interfere with the grass ejection and impair the cutting quality. To sufficiently cool the engine, keep the engine cover, ventilation grid and engine clean.

Fire hazard! Take particular care that the components at the silencer are clean.

For cleaning, use a hand brush. Remove stubborn dirt with a wooden or plastic spatula. Clean the outside housing parts with a cloth.

Do not clean the device with water spray or high-pressure cleaner! Do not use any aggressive cleaning agents.

General inspection

To make sure that the device can be operated safely, check all nuts, bolts, screws, connections of fuel lines, air filters etc. regularly for proper condition and firm seating. Check the ignition wire and the spark plug connector for damage.

Immediately replace damaged or worn parts, especially covers, silencers or fuel tank (authorised service centre).

Check all parts that contain fluids for leaks and proper condition. These can be: Fuel tank, fuel valve, fuel lines, carburetor, engine, gears, battery, hydraulic system.

In case of leaks, contact an authorised service centre.

Checking the traction drive

1. Put the device on a non-slip surface (e.g. concrete or asphalt).
2. Switch off the engine.
3. Actuate the drive.
4. Try to pull the device backwards.

If the rear wheels lock, the drive is correctly adjusted. If you can pull the device, the drive must be re-adjusted.

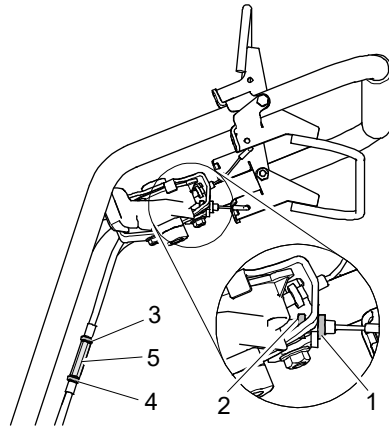

Readjusting the drive

The drive can be readjusted in two places.

1. Slacken the nut (1) and rotate in direction of the drive bar.
2. Tighten nut (2) in direction of the drive bar.

Or:

1. Slacken nut (3).
2. Slacken nut (4) (left-hand thread).
3. Turn the sleeve (5) on the drive away from the nut (3).
4. Tighten the nut (3+4) by turning it towards the sleeve.

Adjust the drive so that

- the wheels are blocked when the drive is actuated when the drive is pulled,
- the wheels turn freely when the drive is actuated.

If there is no improvement after the adjustment, have the device checked by an authorised service centre.

Beware! If the drive is not correctly adjusted, the gearbox can overheat and be damaged.

Checking engine brake

Check the function of the engine brake by switching off the engine. The blade must come to a standstill from full speed within less than 3 seconds. Contact an authorised service centre if this is not the case.

Checking the blade



Danger!

Improperly mounted and maintained blades pose a severe injury hazard.

Work at the blade shall only be performed by an authorised service centre.



Use solid gloves when you check the blade.

Work at the blade requires specific expertise because an unbalance inspection is necessary and the torques must be observed.

Check the blade and all fastening elements for wear, damage and cracks

- each time before and after you mow.
- if there are noticeable changes.

All shown blade parts and their fastening elements must be changed

- if damage or cracks are detected.
- at least once a year or every 50 operating hours, no matter if wear does exist or not. The material weakens, can suffer cracks, endangering people and material assets.

Vibrations are an indication that

- the blade is worn excessively or on one side or
- damage to the engine or cutter deck fastening.

Blades that are sharpened improperly increase the workload of the devices and can result in vibration cracks or breaks.

Ejected broken pieces can cause severe injuries.

Blade change

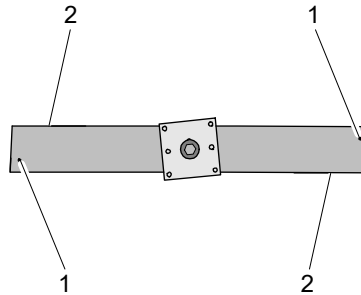

It is absolutely necessary to change the blade:

- When one of the wear markings (1) was reached. Original blades are engraved with wear markings (marking in form of a ball-shaped imprint on the rear side of the blade).
- When the thickness of the blade at the rear edge of the vane (2) or at another point is below 1 mm (exception: cutting edge).

Original blade

An original AS-blade is engraved with:

AS XXXXXXXX

The engraving shows the spare part number.

Maintenance especially for 4-stroke devices

Maintaining the engine



Danger!

If the speed of rotation is set too high, objects can be ejected. The engine can be damaged and noise pollution increases.

Do not change the basic setting of the carburetor or the speed control.

The engine manufacturer has prepared the operating manual of the engine. The manual contains all maintenance requirements and warranty conditions for the engine. If warranty work at the engine is required, contact your authorised service centre or the next authorised dealer for engines.

To ensure a long service life of the engine, sufficient engine cooling is required.

Keep the

- engine cover (ventilation grid),
 - silencer (protective grid) and
 - cooling fins of the engine
- clean at all times.

Checking the engine oil level

Never allow the oil level to be too low otherwise the engine can be damaged. Never fill in too much oil. Otherwise, there is the risk that the oil enters and destroys the air filter.

For this, observe the attached operating instructions of the engine.

Checking the spark plugs



Danger!

The ignition system generates an electromagnetic field.

Wearers of pacemakers must not work on live parts.

Soiled spark plugs reduce the engine output. Clean the electrode of the spark plug with a brass wire brush. Check the electrode gap (see operating instructions of the engine manufacturer). Make sure that the insulator around the electrode is not damaged. Never use a damaged spark plug.

Tighten the spark plug using the correct torque (see operating instructions of the engine manufacturer).

Maintaining the air filter



Danger!

Cleaning agents pose a fire and explosion hazard.

Never clean the air filter with flammable solvents.

Make sure that the air filter is always clean. A dirty air filter reduces the engine power and leads to increased engine wear and fuel consumption. Independent of the operating hours, change the filter insert at least once a year. Do not operate the engine without air filter.

For this, observe the attached operating instructions of the engine.

Maintenance especially for 2-stroke devices

Maintaining the engine



Danger!

If the speed of rotation is set too high, objects can be ejected. The engine can be damaged and noise pollution increases.

Do not change the basic setting of the carburetor or the speed control.

To ensure a long service life of the engine, sufficient engine cooling is required.

Keep the

- engine cover (ventilation grid),
 - silencer (protective grid) and
 - cooling fins of the engine
- clean at all times.

Checking the spark plugs



Danger!

The ignition system generates an electromagnetic field.

Wearers of pacemakers must not work on live parts.

Soiled spark plugs reduce the engine output. Clean the electrode of the spark plug with a brass wire brush. Check the electrode gap (see "Technical data"). Make sure that the insulator around the electrode is not damaged. Never use a damaged spark plug.

Tighten the spark plug with the torque indicated in the technical data.

Maintaining the air filter



Danger!

Cleaning agents pose a fire and explosion hazard.

Never clean the air filter with flammable solvents.



Caution!

A cleaning of the air filter with compressed air damages the filter fabric and the air filter becomes useless.

Change the air filter when it is dirty.



Caution!

When you use air filters from accessory suppliers, the engine can be damaged.

Only use the original AS-Motor air filter cartridges.

Make sure that the air filter is always clean. A dirty air filter reduces the engine performance and leads to increased engine wear and fuel consumption. Irrespective of the operating hours, change the filter insert at least once a year. Cleaning the air filter is not possible. Do not operate the engine without air filter.

Beware! During filter change, accumulated dirt in the air filter can get into the carburetor and damage it.

1. Screw off the air filter cap.
2. Carefully pull out the filter element. Make sure that no dirt from the inside of the air filter housing enters the carburetor.
3. Close the suction opening with a clean cloth.
4. Thoroughly clean the inside of the air filter housing.
5. Remove rough, loose dirt from the filter element by tapping. Replace the filter element in case of heavy, stubborn dirt.
6. Remove the cloth of the suction opening.
7. Re-insert the filter element.
8. Close the air filter cap again.

Assembly

Scope of delivery

The device is shipped in a carton.

The scope of delivery includes:

- The device.
- Mulching plate (only 2in1).
- Impact protection (only 2in1).
- This operating manual.
- Tool bag with small parts.
- Manufacturer's certificate.
- Operating manual engine manufacturer (for 4-stroke devices).

Unpacking

1. Remove the loose parts from the box.
2. Cut open the front side of the box.
3. Push the device out of the box

Mounting guide bar and handlebar

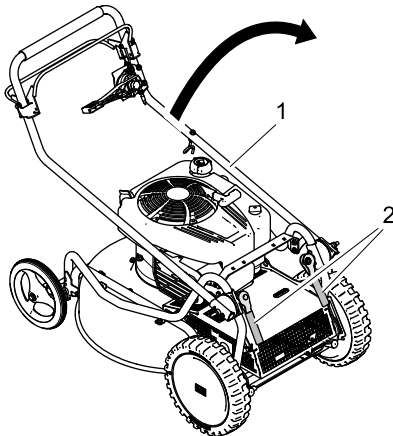

1. Move the guide bar (1) backwards.
2. Adjust the guide bar to the desired height and tighten with the two eccentric tension levers (2).

Mounting the impact protection (only 2in1)



Caution!

When mowing without mulching plate or impact protection, objects can be ejected.

Mow only when the impact protection of mulching plate was installed.

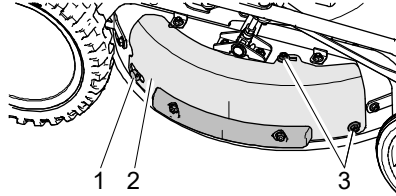

1. Slacken the nuts (3) and remove the screws (3).
2. Remove the mulching plate (2) by pushing the mulching plate to the left and remove it from the support (1).

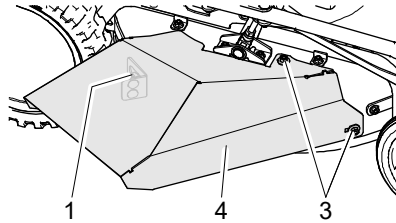

3. Insert the impact protection (4) into the support (1) and push the impact protection a little to the right.
4. Insert the screws (3) from the inside of the device housing into the holes.
5. Screw down the impact protection (4) with the nut (3).

Mount the mulching plate in the reverse order of steps.

Storage

Storing the device

Keep the device in a closed, dry, and well ventilated room and out of reach of children. Always eliminate all problems of the device before you store it so that the device is always in a safe-to-operate state. Let the engine cool down before you store the device in closed rooms.

Longer storage

1. Observe the safety instructions regarding the handling of fuel.
2. Draining fuel tank: Put a piece of a tube on the fuel valve and fill the fuel in an adequate fuel container.
3. Emptying carburetor: Start the engine and let it run until it stops on its own.
4. Clean the device thoroughly.
5. Touch up defects in painting (for spray paint, see Accessories).
6. Performing corrosion protection on the engine:
 - Unscrew the spark plug.
 - Fill a tablespoon of engine oil into the spark plug opening.
 - Pull the starter rope slowly until you get resistance (oil distribution in the cylinder).
 - Re-insert the spark plug and screw in fully.
 - Do not fit the spark plug connector!

In autumn, have your device checked by an authorised service centre!

Restarting

If you want to start the device after a longer storage, carry out the tasks described in chapter Maintenance.

Spare parts

The reliable and safe operation of the device also depends on the quality of the spare parts used. Only use original spare parts and accessories that were approved by "AS-Motor Germany". When foreign parts are installed, the warranty and guarantee shall be void for the foreign part and for the device and for any resulting damage.

Inform your authorised service centre about the device type and serial number of your devices when you order spare parts.

Wear parts

Some parts are wear parts. They wear during use and must be replaced. The warranty does not cover the following parts:

Blades, cutting blades, cutter bars, blade bolts, sliding plates, V-belt, chains, Bowden cables, starter ropes, pressure plates, air filters, spark plugs, disc springs, lock washers, fuses, discs, thrust plates, pressure discs, protection skirts, impact protection, wheels, tires.

Disposal

Grass clippings must not be thrown into the waste but should be composted.

Shredded plant material decomposes quickly, can be utilized as fertilizer, and, therefore, be left on the ground.

Dispose of waste oil and fuel in accordance with the local regulations or return it to an oil shop.

Packaging, device, and accessories are made of recyclable materials and must be disposed of accordingly.

Warranty

Please see our AS-Motor website for warranty information.

Please print out the documents that you receive during the online registration. Keep them together with your sales receipt.

Troubleshooting

The following table contains the most frequent problems and their elimination. If more problems occur, contact the closest authorised service centre.

You can find an authorised service centre on our home page www.as-motor.de.

Problem	Possible cause	Remedy
Engine does not start	Engine brake lever is not pressed.	Press the engine brake lever towards the handlebar.
	Fuel valve is closed.	Open fuel valve
	Tank ventilation screw is closed.	Open tank ventilation screw.
	No fuel is in the tank.	Refill fuel.
	Choke is open.	Close the choke.
	Device was tilted – oil leaked into the air filter.	Replace air filter, unscrew spark plugs and start several times when the fuel valve is closed, dry the spark plugs and screw them back in.
	Engine was flooded due to too many start attempts.	Unscrew spark plugs and, while the fuel valve is closed, the choke is open and at full throttle, start several times, dry the spark plugs and screw them back in.
	Spark plug connector is pulled off.	Observe the safety instructions! Put spark plug connector back on.
	Air filter is dirty.	Maintain air filter (see Maintenance).
	Spark plugs are dirty, damaged, or incorrect electrode gap.	Clean spark plugs and check electrode gap (see Maintenance). Replace spark plugs if necessary.
	Wrong spark plug connector.	Use the specified spark plug connector (see spare part information of the authorised service centre).
	Housing of the mower is jammed.	See Maintenance.
	Poor quality, dirty, or old fuel.	Clean fuel system (authorised service centre). Always use fresh fuel.
Blade is loose.	Authorised service centre.	

Engine starts badly or runs irregularly	Choke is closed.	Open the choke.
	Air filter is dirty.	Maintain air filter (see Maintenance).
	Poor quality, dirty, or old fuel.	Always use fresh fuel.
	Spark plug is dirty, damaged, or incorrect electrode gap.	Clean spark plug and check electrode gap (see Maintenance). Replace spark plug if necessary.
	Wrong spark plug connector.	Use the specified spark plug connector (see spare part information of the authorised service centre).
	Housing of the mower is jammed.	See Maintenance.
No or insufficient drive when the drive bar is actuated.	Drive belt is insufficiently tensioned.	Authorised service centre
	Drive train is incorrectly adjusted.	Check the drive (see Maintenance and cleaning).
	Clutch is worn.	Check the drive (see Maintenance and cleaning).
The blade slides	Replace friction discs.	Authorised service centre.
Strong vibrations during operation	Unbalance at the blade caused by incorrect sharpening or chips on the blade.	Have blade resharpened and balanced by an authorised service centre. Replace a damaged blade immediately.
	Blade drive shaft is bent due to collisions with foreign objects.	Authorised service centre.
	Engine fastening is loose.	Authorised service centre.
	Blade fastening is loose.	Authorised service centre.
Irregular noises	Loose fastening elements.	Authorised service centre.
	Silencer is defective.	Authorised service centre.
Engine is smoking	Air filter is dirty or drenched with oil.	Maintain or replace air filter (see Maintenance).
	Oil level is too high.	Have authorised service centre lower the oil level up to the marking.
Engine gets hot	Ventilation grid is dirty.	Clean ventilation grid.
	Oil level in the engine is too low (4-stroke devices).	Refill engine oil (see operating instructions of the engine manufacturer).
	Cooling fins of the engine are dirty.	Have cooling fins cleaned by authorised service centre.

Uneven cut, lawn becomes unsightly	Blade is dull or worn.	Have blade resharpened and balanced by an authorised service centre. Replace a damaged blade immediately.
	Speed is too high proportionately to the cutting height.	Reduce speed and/or select the correct cutting height.
	Housing of the mower is heavily contaminated.	Clean.
Housing is jammed	Mowed grass was too long or too damp.	Adjust cutting height and mowing speed to the mowing conditions.
	Blade is worn.	Authorised service centre.
	Engine speed is too low.	Authorised service centre.
The device does not stop	Drive belt does not declutch.	Authorised service centre.
The engine does not switch off	Switching off system is defective.	Close the fuel valve. Authorised service centre.

Accessories

Spray paint 400 ml, colour orange:	G00011050
Operating hours counter:	G06927008
Front and side protection:	G51080002
Clinometer:	G06950027
5 litre tank (only for 4-stroke device):	G51080001

Fuel ratios of fuel 2-stroke devices

Fuel	Fully synthetic two-stroke oil	Only with Titan 2T 100S
(octane rating ROZ 91 min.)	1:50	1:100
litres	Litre (=ml/cm ³)	Litre (=ml/cm ³)
1	0.02 (20)	0.01 (10)
2	0.04 (40)	0.02 (20)
3	0.06 (60)	0.03 (30)
4	0.08 (80)	0.04 (40)
5	0.1 (100)	0.05 (50)
10	0.2 (200)	0.1 (100)
20	0.4 (400)	0.2 (200)

Do not use mixtures with more oil than 1:50 (e.g. 1:35).

Too much oil results in carbon deposits and reduces the service life of the engine.

Only use the fully synthetic two-stroke oils explicitly intended for mixing. Do not use mineral two-stroke oil.

Use of engine oils or even waste oil results in engine damage.

No warranty is given in these cases.

Technical data 4-stroke devices

Type	AS 510 4T A	AS 510 2in1 4T A
Range of application (temperature)	0 - 30 °C For temperatures below 5 °C observe the information of the engine manufacturer regarding the engine oil.	
Engine, type Manufacturer Type Cylinder capacity Performance	One cylinder four stroke engine Briggs & Stratton Series 850, I/C 190 cm ³ 3.1 kW (4.3 PS)	
Engine speed	2800 min ⁻¹	2800 min ⁻¹
Cutting device, type Cutting width Cutting width adjustment	Blade 51 cm central 40 – 90 mm, in 6 levels (40 mm, 50 mm, 60 mm, 70 mm, 80 mm, 90 mm)	
Growth height (with impact protection)	up to approx. 20 cm	up to approx. 20 cm (up to approx. 40 cm)
Starting device	Rope start	
Traction drive	Rear wheel drive with Variomat for variable adjustment of the speed (2.0 – 4.0 km/h).	
Maximum area coverage	approx. 2000 m ² /h	
Measures and weight Transport sizes with packaging L/W/H In-service laden mass L/W/H	120/60/71 cm 139/55/100 cm	120/60/71 cm 139/55/100 cm (B: 73 cm with impact protection)
Weight	43 kg	
Capacities Fuel tank Engine oil	1.2 litres approx. 0.65 litres	
Sound level measured sound level L _{WA} measured sound level L _{WA} Sound level at operator station L _{pA}	according to DIN EN ISO 5395 92.4 dB 94 dB 83 dB	according to DIN EN ISO 5395 93.2 dB 95 dB 83 dB
Vibration emission value Hand-arm-vibrations a _{h,w} Measurement uncertainty U	according to DIN EN ISO 5395 2.5 m/s ² 1.5 m/s ²	

Technical data 2-stroke devices

Type	AS 510 2T ES A	AS 510 2in1 2T ES A
Range of application (temperature)	0 - 30 °C	
Engine, type Manufacturer Type Cylinder capacity Performance	One cylinder two stroke engine AS-Motor Germany AS 165 ES (Easystart) 165 cm ³ 3.4 kW (4.6 PS)	
Engine speed	3000 min ⁻¹	3000 min ⁻¹
Spark plug Torque Electrode gap for opt. starting behaviour	NGK BR 6 HS 25 Nm 0.5 – 0.7 mm	
Cutting device, type Cutting width Cutting width adjustment	Blade 51 cm central 40 – 90 mm, in 6 levels (40 mm, 50 mm, 60 mm, 70 mm, 80 mm, 90 mm)	
Growth height (with impact protection)	up to approx. 20 cm	up to approx. 20 cm (up to approx. 40 cm)
Starting device	Rope start	
Traction drive	Rear wheel drive with Variomat for variable adjustment of the speed	
Maximum area coverage	approx. 2100 m ² /h	
Measures and weights Transport size with packaging L/W/H max. tyre dimensions L/W/H	120/60/71 cm 139/55/100 cm	
Measures and weights Transport size with packaging L/W/H Tyre dimensions L/W/H	120/60/71 cm 139/55/100 cm	120/60/71 cm 139/55/100 cm (W: 73 cm with impact protection)
Weight	48 kg	
Capacities Fuel tank	5 litres	
Sound level	according to DIN EN ISO 5395	according to DIN EN ISO 5395
measured sound level L _{WA}	97.5 dB	97.7 dB
measured sound level L _{WA}	98 dB	98 dB
Sound level at operator station L _{pA}	86.9 dB	88.8 dB

Type	AS 510 2T ES A	AS 510 2in1 2T ES A
Vibration emission value	according to DIN EN ISO 5395	
Hand-arm-vibrations $a_{h,w}$	2.3 m/s ²	
Measurement uncertainty U	1.5 m/s ²	

Declaration of conformity

We declare that the lawnmowers

Type	AS 510 4T A	AS 510 2in1 4T A	AS 510 2T ES A	AS 510 2in1 2T ES A
Cutting width	51 cm	51 cm	51 cm	51 cm
starting from serial no.	022711030001	031418020001	030617050001	031318020001

as brought into circulation by us conform to all relevant safety and health requirements of the EC directives listed.

- 2006/42/EC
 - 2000/14/EC
 - 2014/30/EU

Function:

The devices are exclusively intended for the mowing of well maintained grasslands and lawns.

Applied standards:

DIN EN ISO 5395

Applies to 2000/14/EC:

Applied conformity assessment procedure

Annex VI

Type	AS 510 4T A	AS 510 2in1 4T A	AS 510 2T ES A	AS 510 2in1 2T ES A
Measured sound level	92.4 dB	93.2 dB	97.5 dB	97.7 dB
Guaranteed sound power level	94 dB	95 dB	98 dB	98 dB

Notified body:

DPLF, 64823 Groß-Umstadt, EC identification number 0363

Place where all technical records are filed:

AS-Motor Germany GmbH & Co. KG
 Ellwanger Straße 15
 D-74424 Bühlertann

Bühlertann, in March 2018



Eberhard Lange
 Managing director



By proxy Frank Einsiedler
 Head of development



THE HIGH GRASS MOWER AND 2 STROKE ENGINE MANUFACTURE

AS-Motor is your premium manufacturer for lawn and high grass mowers as well as 2 stroke engines. We offer our customers professional technology for steep slopes, rough terrain, and lawn care. Our extensive product range which includes hand-held entry-level devices up to the world's first all-wheel ride-on mower with remote control will always offer private customers, municipalities service providers the right product. For more than 60 years, we have been developing and producing with a high production depth in Southern Germany and supply our dealer network in more than 30 countries all over the world.

Mulching mower	Mulching mower – the time-saving alternative! AS-Motor mulching mowers shred the grass to create such a fine mulch, almost an “invisible” fertiliser, that sinks right away back into the lawn. Disposal of the cuttings is not required.
Professional lawn mower	Professional lawn mowers with rear or side discharge for every requirement, even with all-wheel drive, brake and reverse gear.
Brush cutter®	An agile lawn mower for maintenance of extensive grassed areas. The Allmäher® reliably mows and mulches metre-high grass, brushes and weeds.
Flail mower	High grass with undergrowth, steep slope or extensive areas in unknown terrain? The movably mounted flail blades of the AS-Motor flail mower give way to rocks and obstacles and chop the cuttings several times over.
Ride-on brush cutter	If extensive areas, weeds and undergrowth up to 1.2 m, the AS-Motor all-wheel mowers are also perfect for steep and even extremely steep terrain. Ease of use and high area performance combined in one compact ride-on mower. For more safety, comfort and efficiency in difficult terrain we have developed the innovative and the world's first remote controlled ride-on mower.
Rotary mower	The cost-effective alternative to the cutter-bar mower. Also ideal for feed production. The grass is not shredded but deposited in straight rows as a windrow next to the machine.
Weed remover	Careful and chemical-free weed removal. The AS-Motor weed removers “WeedHex” mechanically clean paved areas and curb stones from growing weeds – quickly, safely, and efficiently.